

 **IO-Link**



Pyrometer *CellaTemp PX 41/61*

Ident no.: 1102813 06/2025

Content

1	General	5
1.1	Information about the manual	5
1.2	Explanation of the symbols	5
1.3	Liability and Warranty	5
1.4	Copyright	6
2	Safety	6
2.1	Intended use	6
2.2	User's responsibility	6
2.3	Safety requirements	6
2.4	Laser Radiation Hazard	7
3	Shipping, packaging and disposal	8
3.1	Inspection after shipping	8
3.2	Packaging	8
3.3	Disposal of the old devices	8
4	Theory of Non-Contact Temperature Measurements	9
4.1	Advantages of Non-Contact Temperature Measurement	9
4.2	Measurements at Black Bodies (Cavity Radiators)	10
4.3	Measurements of Real Radiators	10
4.4	Measurements errors	11
5	Ways to determine emissivity (one-colour mode)	11
6	Function	12
7	Installation	12
7.1	Assembly basic unit	12
7.2	Assembly fibre optic cable	12
7.3	Alignment	13
7.4	Focussing	14
8	Electrical connection	15
9	Setup	16
9.1	Setup two-colour mode	16
9.2	Setup one-colour mode	17
9.3	Transmission factor (one-colour mode)	18

10	Shielding and Grounding	18
11	Operating control and display	19
11.1	Processing of measuring signals.....	20
11.2	Analogue output	20
11.3	Switching threshold OUT 1.....	21
11.4	Output signal	21
11.5	Switch on delay	21
11.6	Switch off delay	21
11.7	Hysteresis function.....	22
11.8	Window function.....	23
11.9	Switching output OUT 2	24
11.10	Dirt alert.....	24
11.11	Damping function.....	25
11.12	Peak hold function.....	25
11.13	ATD function.....	26
11.14	IO-Link.....	30
12	Menu.....	30
12.1	Analogouge output Ao.....	30
12.2	Switching output OUT 1	31
12.3	Switching output OUT 2	32
12.4	Two-colour channel.....	33
12.5	Spectral channel Lambda 1	34
12.6	Spectral channel Lambda 2	35
12.7	Advanced Features	36
13	Menu explanation	37
13.1	Analogue output.....	37
13.2	OUT 1 (d1).....	37
13.3	OUT 2 (d2).....	38
13.4	Two-colour channel (90).....	39
13.5	Spectral channel (L 1) (L 2).....	41
13.6	Advanced Features (EF).....	43
14	Parameterizing.....	44
14.1	Setting parameters – general information.....	44
15	Error indications.....	45

16	Service functions	46
16.1	Reset all parameters to factory settings.....	46
16.2	Simulate a desired temperature.....	46
17	Maintenance	47
17.1	Cleaning the pyrometer lens	47
17.2	Replacing the protective screen.....	47
18	Models	48
19	Field of view.....	48
20	General technical data.....	49
21	Device-specific technical data	51
22	Accessories	54
24	Default settings.....	54
25	Copyright	54

1 General

1.1 Information about the manual

The purpose of the Operating Manual is to provide the user with all necessary information to be able to install the pyrometer and any necessary accessories. Before starting installation, be sure to read and understand this entire manual, in particular the chapter on safety! The instructions contained in this manual, especially those concerning safety, as well as site specific regulations governing UV radiation must be complied with at all times. It is imperative to comply with the safety instructions and the accident protection regulations valid for the area of application!

1.2 Explanation of the symbols

Important safety-related references in this manual are marked with a symbol.

ATTENTION

This symbol points out guidelines. If you do not observe them, the device might be damaged, malfunctioning or even fail to operate.



CAUTION

This symbol points out guidelines which should be followed for efficient and trouble-free operation.

- ▶ Action
This symbol instructs the operator to take action.
- > Reaction, result
This symbol indicates the result of the action taken.

1.3 Liability and Warranty

All information compiled in this manual is in accordance with applicable regulations. The statements made are based on state-of-the-art technology and reflect our extensive knowledge and many years of experience.



Always carefully read this Operating Manual before beginning any work on or with the instrument, especially prior to installation and initial setup! The Manufacturer shall not be held liable for any damages or malfunctions arising from a disregard of the warnings and instructions contained herein.

1.4 Copyright

This Operating Manual should be treated as confidential. It is solely intended for the use by persons involved with the instrument. This manual may not be made available to a third party without prior Manufacturer's consent. Please contact the Manufacturer if the need should arise.

2 Safety

This chapter outlines all important safety aspects to be considered for optimum employee protection and to ensure safe and reliable operations.

2.1 Intended use

The pyrometer is solely intended for use as described in this manual. Operational safety can only be ensured when the instrument is used for its intended purpose.



The use of the pyrometer for any other purpose beyond what is specified in this manual is prohibited. Using the instrument in any other manner will be considered as improper.

The manufacturer is only liable for damage that occurs during correct use. The prerequisite for any liability, however, is that the cause of the damage is due to a defective product and the defect in the product was caused by the manufacturer.

2.2 User's responsibility

The pyrometer may only be used when it is in perfect working condition.

2.3 Safety requirements

The instrument operates at low voltage (18 – 34 V DC). The power supply unit must conform to directive EN 50178, SELV, PELV.

2.4 Laser Radiation Hazard

Laser radiation can be harmful to the eye!

The CellaTemp PX with laser operates with a class 2 red light laser. Direct prolonged viewing of a laser beam can injure the retina. Therefore, the following safety precautions must be strictly observed, otherwise the laser may not be operated!

- Only use the laser to align and focus the pyrometer. Deactivate the laser immediately afterwards. Alternatively, the laser will automatically switch off after 2 minutes.
- Never look directly into the laser beam path
- Do not leave the instrument unattended when the laser is activated.
- Do not point the laser beam at any person
- During pyrometer installation and alignment, make sure to avoid the possibility of laser reflections caused by reflective surfaces.
- All currently valid laser safety standards must be observed.

Laser power

The laser operates at a wavelength of 630 - 680 nm (visible red light). The emitted power of the laser beam at the lens opening is max. 1.0 mW. Under normal operating conditions, the emitted radiation does not present a danger to human skin. This laser product is classified according to laser class 2, EN60825-1, IEC60825-1.

Laser Warning Label

The black and yellow laser warning label is affixed next to nameplate of the instrument. An arrow indicates the laser emission path (lens opening).





If the pyrometer is installed within, a machine or equipment in such a way that the instrument's warning label is visibly blocked, additional laser warning labels (not included in scope of delivery) must be affixed to the equipment or accessory in immediate vicinity to the laser beam emission path opening.

3 Shipping, packaging and disposal

3.1 Inspection after shipping

Unpack and inspect the entire shipment immediately upon receipt to make sure it is complete and undamaged. If the container/package shows visible signs of damage, please refuse the shipment. If this is not possible, accept the shipment on the condition that the freight carrier's delivery record is noted with the extent of the damage in order to file a claim. Should you discover a concealed loss or damage, report it to the shipper or freight carrier immediately. If the period for filing claims has expired, you will no longer be able to make any claims for compensation of damage or loss.

3.2 Packaging

The packages used are made of carefully selected, environmentally compatible materials and are thus recyclable. Please ensure that they are disposed of in an ecologically sound manner.

3.3 Disposal of the old devices



Old electrical and electronic devices frequently still contain valuable materials. These devices can be returned for disposal to the manufacturer or they must be disposed properly by the user.

For the improper disposal of the device by the user, the company KELLER HCW is not responsible.

4 Theory of Non-Contact Temperature Measurements

All materials radiate thermal energy in all states of aggregation above absolute zero. This radiation is mainly caused by atomic or molecular oscillations.

This temperature radiation is only a limited sector within the total electromagnetic radiation spectrum. It extends from the visible range starting at wavelengths of approx. 0.5 μm to the infrared range with wavelengths of more than 40 μm . Radiation pyrometers detect infrared radiation for non-contact temperature measurement.

EN

4.1 Advantages of Non-Contact Temperature Measurement

- Non-contact temperature detection means cost-effective temperature measurement because this technique only requires a single investment in an instrument without any follow-up costs for consumables such as thermocouples
- This method enables temperature detection of moving objects - quick temperature measurements within milliseconds - for example at automatic welding processes
- Small objects with medium and high temperatures can also be easily and accurately measured
- When measuring materials with low specific heat, a non-contact method does not induce heat loss which would distort the temperature reading (as is the case with contact temperature probes). Non-contact temperature detection is ideal with corrosive molten materials for which the use of thermocouples is hardly feasible
- Last but not least it is also possible to measure the temperature of voltage-carrying objects.

4.2 Measurements at Black Bodies (Cavity Radiators)

A black body or a black radiator is used to calibrate radiation pyrometers. This black body is designed in a way that its radiation does not depend on material characteristics, but only on its temperature. A black body emits at any wavelength the maximum energy possible for the specific temperature. Real bodies do not have this ability. In other words, a black body completely absorbs the radiation without reflection or transmission losses. The spectral emissivity coefficient $\epsilon(\lambda)$ of a black body is equal to 1 or 100 %.

The emissivity coefficient indicates the ratio of radiation of a real body (target) to the radiation of an ideal black body (target) to the radiation of an ideal black body.

$$\epsilon(\lambda) = \frac{M}{M_S}$$

$\epsilon(\lambda)$: Emissivity coefficient of the object's surface (targeted spot) at wavelength λ

M: Emissivity coefficient of the object's surface (targeted spot) at wavelength

MS: radiant energy emitted by a black body (perfect radiator)

Most burning, annealing and hardening furnaces emit a radiation of nearly ,1' which corresponds to the conditions of a black body if the aperture through which the measurement is made is relatively small.

4.3 Measurements of Real Radiators

Real radiation sources are characterized by the relation of the emitted radiation to the radiation of a black body with the same temperature. Measurements outside a furnace - which applies to all other self-contained targets - always show a reading which is too low. Considerable errors can occur at targets with reflecting, polished or bright surfaces, e.g. molten steel and metal without oxide layer and ceramic materials. Exact results can only be obtained when the emissivity coefficient is correctly adjusted on the pyrometer. The spectral emissivity coefficient of a body does not represent an exact material constant, but is also largely dependent on the surface properties (→ Ways to determine emissivity).

4.4 Measurements errors

The cause of measurement errors in the use of pyrometers is often an incorrectly determined or wrong emissivity. Another source of error is the reflected „background radiation“. If the measurement object has a low emissivity and there are hotter objects in the surrounding area, measurement results can be affected. These objects then have to be shaded. This effect is particularly to be observed in the measurement of a colder object within a hot oven.

5 Ways to determine emissivity (one-colour mode)

Technical literature or operating manuals often contain data on the emissivity of various materials. This information should be used with caution, however. It is important to know for which temperature and which wavelength the emissivity value is applicable. Furthermore, the stated emissivity values were obtained under ideal conditions. In actual practice, the total emissivity of the target object will vary, depending on the amount of extraneous radiation transmitted through the object from the background or reflected onto the object from the foreground. The emissivity can be determined using one of the following methods:

Contact measurements

Measure the temperature with a contact thermocouple and measure the surface temperature with a pyrometer. Adjust the emissivity coefficient on the pyrometer until both devices show the same temperature. When measuring with the thermocouple, make sure to have good thermal contact and low heat dissipation.

Using a reference emissivity coefficient

Apply matte black colour to a part of the surface to be measured. This part has an emissivity of 94 %. At first, measure the temperature of the coloured part. Then make a comparative measurement right next to the coloured part and adjust the emissivity on the pyrometer until it displays the previous measurement reading again.

6 Function

The pyrometer detects the radiated infrared radiation of objects without contact and converts them into an electrical switching signal and an analogue output signal.

7 Installation

7.1 Assembly basic unit

The basic unit should be mounted where it is not unnecessarily exposed smoke, heat or vapour.

ATTENTION

At ambient temperature > 65 °C, the basic unit must be cooled or protected against radiation by shielding plate.

7.2 Assembly fibre optic cable

One end of the optical fibre has a nameplate showing the serial number of the corresponding basic pyrometer. This is the end which must be screwed onto the pyrometer. For proper connection, the arrow on the name plate of the fibre optic cable and the arrow on the pyrometer should point toward each other.

The serial number of the measuring head should also correspond to the pyrometer.

ATTENTION

The fibre optic cable must not be exposed to tensile load and must not be twisted. The minimum bending radius is 125 mm.

7.3 Alignment

Align the pyrometer with the object to be measured. The pyrometer should, if possible, be installed at an angle of 90° to the measuring object. The angle should not be less than 45° from the vertical. When measuring with a two-colour pyrometer, the field of view does not have to be filled entirely by the target object.

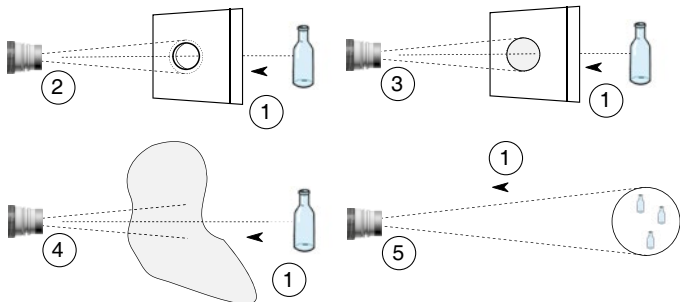

EN

1	Radiated energy
2	Visibly smaller than measuring spot
3	Lens or protective screen contaminated
4	Steam, dirt or gas in the atmosphere
5	Object is smaller than the measuring field or object is moving



If the pyrometer is operated in spectral measurement mode, the measurement object must completely fill the measuring field.

7.4 Focussing

The pyrometers have a laser that can be activated to align the sensing head to the target spot. To activate the laser, press the MODE button in the real panel for 2 seconds.

For focal adjustment loosen the shown socket screw (hexagon socket screw DIN 916) with a wrench (DIN 911) and shift the internal body of the tube towards the lens tube. Due to the O-ring sealing between the internal body of the tube and the lens tube the focal adjustment must be carried out very slowly so that the air pressure in the space between lens and internal body of the tube can be equalised.

Focus the sensing head until the spot light is shown as a sharp round laser spot in the target area.

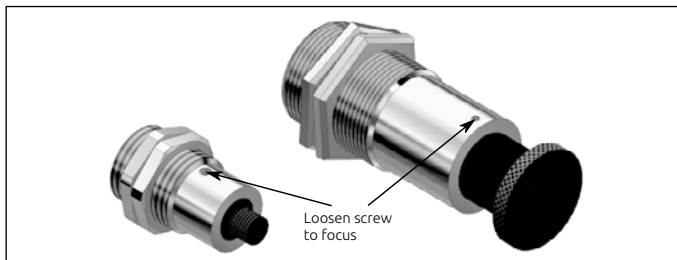

The activated laser pilot light can influence the measured temperature. This influence will vary, depending on the instrument model and the temperature.

To protect the laser against overload, an over temperature is provided. At temperatures above 60 °C, the laser switches of an can no longer be activated. To check, whether the laser is activated, the parameter LED lights up.

In normal operation, the laser is switch off. After activation, the laser switch of again after 2 – 15 minutes. The operator must be familiar with the pyrometer and above safety guidelines.



Information on the laser output can be found in chapter 2.4

8 Electrical connection

⚠ ATTENTION

- The pyrometer may only be installed by a skilled, qualified electrician. Do not connect the instrument while the voltage supply source is turned on. Please observe international safety regulations at all times.
- The pyrometer is supplied with low voltage 24V DC. The power supply unit must conform to directive EN50178, SELV, PELV.

EN

- ▶ Switch to neutral and verify absence of voltage
- ▶ Connect the instrument according to the following schematic:

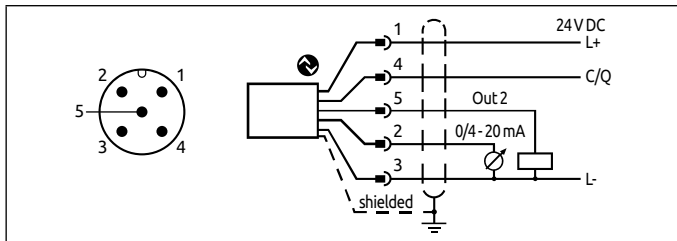

Pin 1	BN (brown)	L+ (Power supply 24V DC)
Pin 4	BK (black)	Open Collector switching output; $I_{max} = 150 \text{ mA}$ or IO-Link OUT 1
Pin 5	GY (grey)	Open Collector switching output; $I_{max} = 150 \text{ mA}$ OUT 2
Pin 2	WH (white)	Analogue output; 0/4 - 20mA
Pin 3	BU (blue)	L- (GND)



The pyrometer must be protected against high voltage and strong electromagnetic fields. Use a shielded cable, connecting it via connector casing to the device housing.



Use a flyback diode when switching inductive loads.

9 Setup

The pyrometer uses the intensity of infrared radiation for the non-contact temperature measurement.

The pyrometer PX can be used as spectral or two-colour pyrometer.

When delivered, the pyrometer is configured for the two-colour measurement.

9.1 Setup two-colour mode

The two-colour measuring method detects the infrared radiation at two different wavelengths and calculates the quotient from the values obtained. This measurement method is suitable for measurements of targets that are partially obscured (either intermittently or permanently) by other objects, openings, screens or viewing windows that reduce energy, and by dirt, smoke, or steam in the atmosphere. The two color mode can also be used on targets that do not completely fill the target spot, provided the background is much cooler than the target.

Setting the emissivity ratio (two color mode)

The difference between measured temperature and true temperature can be compensated by changing the emissivity ratio. Make this adjustment for selective interferences or when the emissivity for wavelength 1 and wavelength 2 will be different because of the material that is being measured.

• Emissivity ratio [9.0] → [9.5 P] = 80 - 120 %

▶ Press [Λ or v]

> The value of the selected emissivity ratio is displayed, for example [10.00]

▶ Press [Λ or v] until the desired emissivity will show

▶ Press [Enter] or wait for 3 seconds

> The current temperature value is displayed and the new emissivity coefficient is stored

9.2 Setup one-colour mode

By default, the pyrometer is set for quotient measurement. If the pyrometer is to be used as a spectral pyrometer, the configuration of the analogue output must be changed to spectral mode.

Measuring mode one-colour mode

[R0] → [R0 S] = [L 1] or [R0] → [R0 S] = [L 2]

Exact temperature readings in the operating mode "spectral measurement" can only be obtained when the emissivity of the target is correctly adjusted on the pyrometer. The pyrometer thus automatically compensates the reduced radiation by the lower emissivity.

• Emissivity: [L 1] → [E P S] = 10...110% or [L 2] → [E P S] = 10...110%

▶ Press [Λ or v]

> The value of the selected emissivity is displayed, for example [1000]

▶ Press [Λ or v] until the desired emissivity will show

▶ Press [Enter] or wait for 3 seconds

> The current temperature value is displayed and the new emissivity coefficient is stored



To compensate for environmental influences, it may be useful to have an emissivity of > 100 %. A setting of 110 % is possible.



Emissivity determination Chapter 5

9.3 Transmission factor (one-colour mode)

Besides the emissivity correction, a pyrometer must be adjusted for the transmission properties of any supplementary lens and/or protective window screwed onto the pyrometer. Set the pyrometer for the specific transmission factor (a percentage value) which is indicated either in the product's data sheet or on the lens itself. If you are not using any auxiliary lens or protective window, set the parameter to 100.0 (default setting).

- Transmission factor [L 1] → ['t AU] = 1000 or [L 2] → ['t AU]

10 Shielding and Grounding

The pyrometer housing is connected to the shielding via the cable connector!

Differences in ground potentials might cause an equalising current to flow between devices through a cable shielded at both ends. In this case, be sure to install an additional equipotential bonding line.

To avoid an equalising current, the pyrometer can be mounted electrically insulated. The shielding must be connected to the plant's earthing system.

ATTENTION

If the pyrometer is installed without an insulator and without potential equalisation, the interference voltage may not exceed 32V.

11 Operating control and display

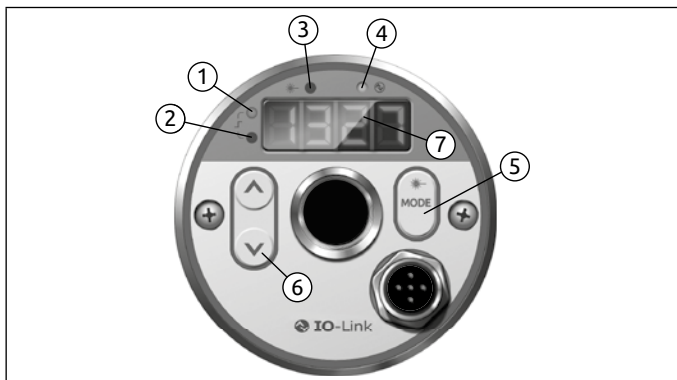

EN

1 to 4: Indicator-LEDs

- LED 1 = Switching state of switching output OUT1
- LED 2 = Switching state of switching output OUT2
- LED 3 = Laser pilot light active
- LED 4 = IO-Link Communication

5: Control key [MODE]

- Selection of parameters
- Reading the set values
- Confirmation of parameter values

6: Control key [^] and [v]

- Selection of parameters
- Activation of emissivity quick adjustment
- Confirmation of parameter values

7: Alphanumeric display, 4-digit

- Indicates temperature value
- Indicates parameter and configuration
- Display of errors

11.1 Processing of measuring signals

The pyrometer disposes of an IO-Link interface.

The generated three output signals correspond to the parameterization:

- Out 1: Switching output/ IO-Link
 - Switch signal: threshold value temperature / status signal
- Out 2: Switching output
 - Switch signal: threshold for temperature / status signal
- Analogue output: 0/4 -20 mA
 - Analogue output for temperature

11.2 Analogue output

The pyrometer converts the measuring signal into a temperature proportional analogue signal of 0/4 – 20 mA. The maximum load is 500 Ohm.

[R_{0F}] Changeover 0 -20 mA or 4 -20 mA

[R_{0SP}] defines at which measured value the output signal is 0/4 mA.

[R_{0EP}] defines at which measured value the output signal is 20 mA.

Maximum measuring range		Measuring range scaled	
1	initial value of the measuring range	3	Analogue start point
2	final value of the measuring range	4	Analogue end point

11.3 Switching threshold OUT 1

OUT1 changes its switching status when the configured upper or lower thresholds $[d\ I.S.P.]$ and $[d\ I.r.P.]$ are exceeded. Source $d\ I.S$ specifies the signal that is output at OUT1.

- Two-colour mode $[d\ I.] \rightarrow [d\ I.S] = 9$

First, the switching point $[d\ I.S.P.]$ is set in °C and °F and then the reset point $[d\ I.r.P.]$. When changing $[d\ I.S.P.]$, the $[d\ I.r.P.]$ also changes so that the difference remains the same. If the $[d\ I.S.P.]$ is reduced to such an extent that the distance can no longer be maintained (as the $[d\ I.r.P.]$ would otherwise move below its minimum), the $[d\ I.r.P.]$ is increased to its minimum. If $[d\ I.S.P.]$ is subsequently increased again, $[d\ I.r.P.]$ is also increased again immediately. The minimum distance between $[d\ I.S.P.]$ and $[d\ I.r.P.]$ is 1 K.

11.4 Output signal

The following output functions can be selected:

- Normally open contact $[d\ I.] \rightarrow [d\ I.F.n] = h.n.o$ hysteresis function, normally open or rather $F.n.o$ window function, normally open
- Normally closed contact $[d\ I.] \rightarrow [d\ I.F.n] = h.n.c$ hysteresis function, normally closed or rather $F.n.c$ windows function, normally closed

11.5 Switch on delay

Once the sensor has detected a temperature which exceeds the switching threshold $[d\ I.S.P.]$ the time delay $[d\ I.d.S]$ starts running. When this delay period has elapsed, the output OUT 1 activates switching. This status is sustained until the lower threshold $[d\ I.r.P.]$ is violated. If this occurs before the time delay has elapsed, the delay will reset. This function can be used, for example, to suppress spurious impulse signals at the output.

- Switching on delay: $[d\ I.] \rightarrow [d\ I.d.S] = 0...10$ sec.

11.6 Switch off delay

To make sure the output is correctly identified, e.g. by downstream control system, the output can be lengthened.

- Switch off delay: $[d\ I.] \rightarrow [d\ I.d.r] = 0...10$ sec.

11.7 Hysteresis function

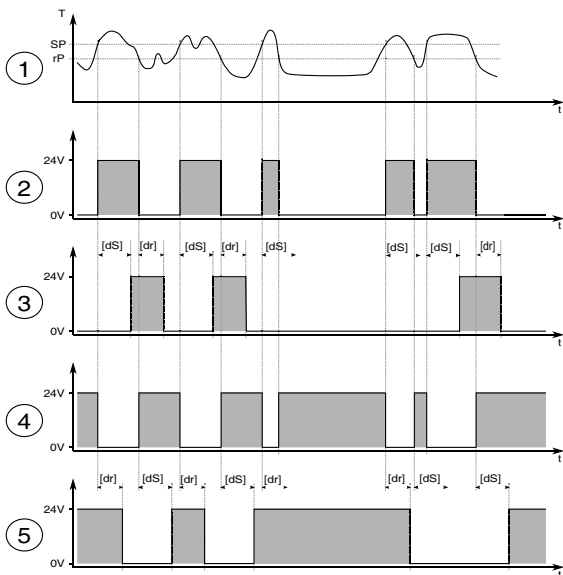

T = temperature

rP = reset point

t = time

dS = switch on delay

SP = set point

dR = switch off delay

1	Temperature
2	Switch signal hoo
3	Switch signal hoo with switch on delay and switch off delay
4	Switch signal hoc
5	Switch signal hoc with switch on delay and switch off delay

11.8 Window function

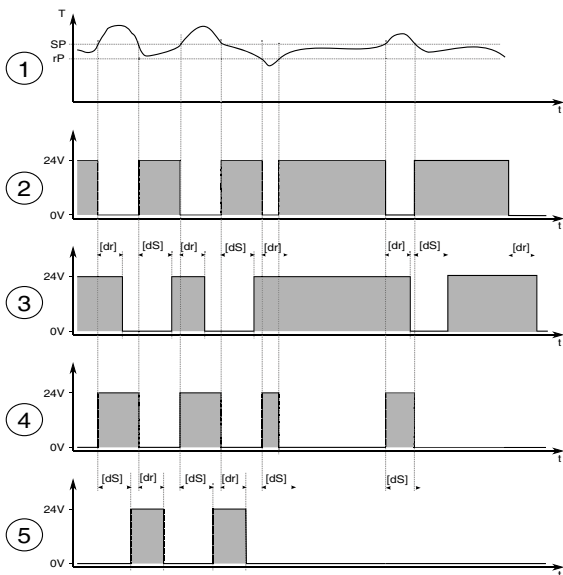

EN

T = temperature rP = lower limit value
 t = time dS = switch on delay
 SP = upper limit value dR = switch off delay

1	Temperature
2	Switch signal F_{no}
3	Switch signal F_{no} with switch on delay and switch off delay
4	Switch signal F_{nc}
5	Switch signal F_{nc} with switch on delay and switch off delay



The switching thresholds of the window function have a hysteresis of 0.25% of the measuring range.

11.9 Switching output OUT 2

OUT2 changes its switching state according to the adjusted function. The functions and parameters are the same as OUT 1.

11.10 Dirt alert

A dirt alert function is available to ensure a safe measurement for the PX pyrometer. The dirt alert function warns the user if, for example, the lens, an attached protective glass or the sighting cone of the pyrometer gets dirty during a measurement.

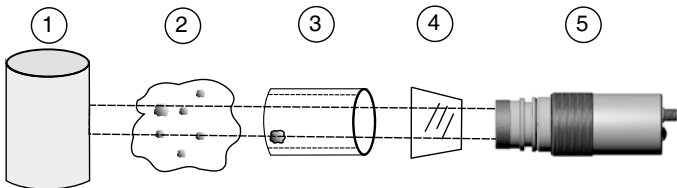

1	Target object
2	Visibility obstructed by vapour and dust
3	Deposits in the sight tube or kiln wall
4	Contaminated viewing window and/or contaminated lens
5	Pyrometer

The parameter dirt alert is activated with the parameter $[d !] \rightarrow [d !S] = d, r$ or $[d 2] \rightarrow [d 2S] = d, r$. The dirt alert is a warning function. The warning will become when the set threshold $[9] \rightarrow [9 d r t]$. During measurements of discontinuous processes, this warning is only active when the target object is detected by the pyrometer and the threshold is violated.

11.11 Damping function

When the target object's temperature is erratic, the damping function smoothens these temperature fluctuations in order to stabilize the measuring signal. The greater the time constant, the lower the effect of fluctuations on the yielded temperature reading.

Two-colour mode [9 0] → [9 F, L]

One-colour mode [L 1] → [F, L] or [L 2] → [F, L]

Ao

[mA]

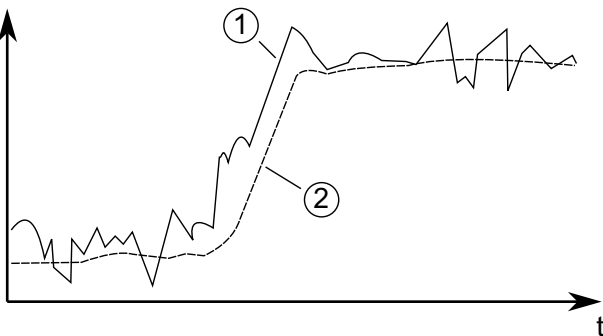

1	Output signal without smoothing function
2	Output signal with smoothing function

11.12 Peak hold function

It might often be desirable to determine the peak temperature during a defined time period, for example when the objects to be measured move past the pyrometer, resulting in temperature readings which would appear to be cyclical. In this mode, the displayed temperature reading will not drop between targeted objects. The peak temperature reading will be held for a preset time period.

The hold time [E , nE] can be set from 0.1 to 999.9 sec. The maximum temperatures sampled during the defined hold time will be saved. It make sense to

choose a hold time which is approximate 1.5 time as long as cycle of the moving targets. This avoids temperature drops. Any changes are recognised at once.

Two-colour mode [9] → [9Phd] → [t , nE]

One-colour mode [L 1] → [Phd] → [t , nE] or
[L 2] → [Phd] → [t , nE]

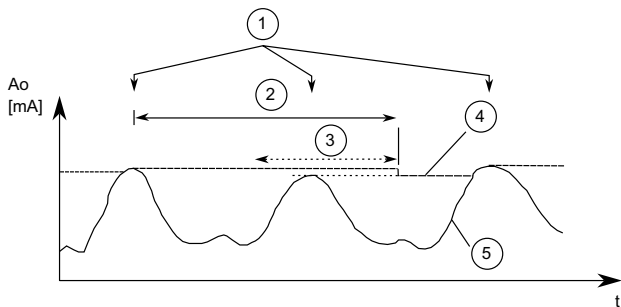

1	Measuring object in front of the pyrometer
2	Hold time
3	Second internal hold time
4	Measuring reading with peak hold function
5	Measuring reading without peak hold function

11.13 ATD function

This function is used to automatically measure the temperature of a discontinuously running process. For example, it can be used to determine the temperature of objects passing the pyrometer acyclically and have a variable size or speed.

The start of a measuring cycle is determined automatically and is dependent on the following variables:

Limit 1 (L1.1)	Before beginning the measurement, the temperature reading must have been lower than Limit 1 at least once. If Autoreset [E R U E = 0 0] the limit 1 will be ignored
Limit 2 (L1.2)	Limit 2 must be exceeded at least for the duration of time delay [E D E L].
Time delay (E D E L):	See above

EN

When the conditions are fulfilled, the sampling time can begin. [E R C E].

Sampling time (E R C E)	During the sampling time the temperature is detected and stored as a temperature value.
--------------------------------	---



If the parameter E R C E = 0, the end of the discontinuous process is also detected automatically (measured temperature < L2). The device then displays 'R U E 0' instead of the time for the parameter E R C E.

The parameter E R 0 0 defines the temperature emitted during the measuring time.

Display mode (E R 0 0)	„OFF“ displays the lower temperature range limit during the measurement. „hold“ indicates the previous temperature reading during the current measurement.
-------------------------------	---

The duration of the measurement time can optionally be signaled at switching output 1 or switching output 2.

When the sampling time has ended, an average value is calculated for recorded measuring cycles. The temperature reading is weighted with the previously saved average value and added.

Weighted average (E F P r)	Factor for average weighting. If you choose 100%, averaging will be off.
-----------------------------------	--

The smaller you set the E F P r factor, the stronger the weighting will be.

When the averaging function is activated (E F P r < 100%) a plausibility check will be performed. The difference in temperature between the current reading and the previously stored average is established. If the difference is higher than the

plausibility threshold TSP, the transmitted data will be „0“ and the average value will remain unchanged.

Plausibility (t FRL)	Threshold for plausibility check: lower limit which is acceptable for a valid measurement.
Plausibility (t r S)	Threshold for plausibility check: upper limit which is acceptable for a valid measurement.

When sampling is completed, the average temperature value or „0“ will be output. At the same time, the switching outputs can be parameterized so that a status pulse is generated at the end of the measuring time. Enter **RRt r** as source and set the hold time to 0.5 sec.

A cut-off interval (time lag) begins after the sampling time has ended. This cut-off interval must expire before the next measurement can start with the cycle starting conditions described above.

Cut-off interval (t d S)	The interval between one completed sampling and the start of a new sampling.
---------------------------------	--

If a measuring cycle does not start during the period **tOUT**, the saved average will be deleted and reinitialized when the next cycle begins.

Timeout (tOUT)	Timeout für Mittelfunktion (in Minuten)
-----------------------	---

Activate auto reset for the ATD function to run cyclically. Limit 1 will then be ignored. Measurement continues when the Limit 2 is exceeded for the period configured with **tDEL**.

Auto reset (t RSt)	Auto reset on/off
---------------------------	-------------------

11.14 The parameter Set Li2 checks on **tRCt** checks, whether the value falls below threshold 2 during the measuring time. If the value falls below the threshold, the measurement is rejected. The display shows „----“.

Set Li2 check on tAct (t L2)	on/off
-------------------------------------	--------

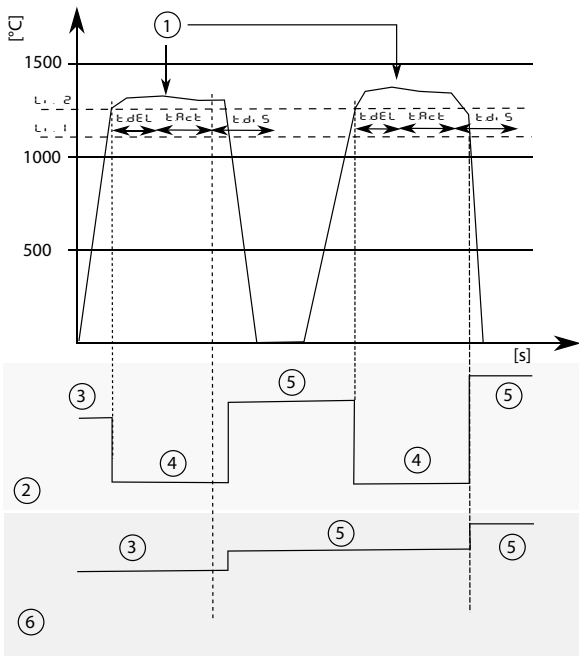

EN

L_2 = limit 2

L_1 = limit 1

t_{dEL} = time delay

t_{Rct} = sampling time

$t_{d.S}$ = cut-off interval

1	Measuring object in front of the pyrometer
2	Temperature output $t_{Rno} = \text{OFF}$
3	Previous reading
4	Lower limit of temperature range
5	New reading
6	Temperature output $t_{Rno} = \text{hold}$

11.15 IO-Link

This device has an IO-Link communication interface, which requires an IO-Link-capable module (IO-Link master) for operation. The IO-Link interface allows direct access to process and diagnostic data and offers the possibility to parameterize the device during operation. The IODDs required for configuring the IO-Link device as well as detailed information on process data set-up, diagnostic functions and parameter addresses are available in the download area at www.keller.de/its.

For IO-Link operation a 3-wire cable port Class A (Type A) must be used.

12 Menu

12.1 Analogue output Ao

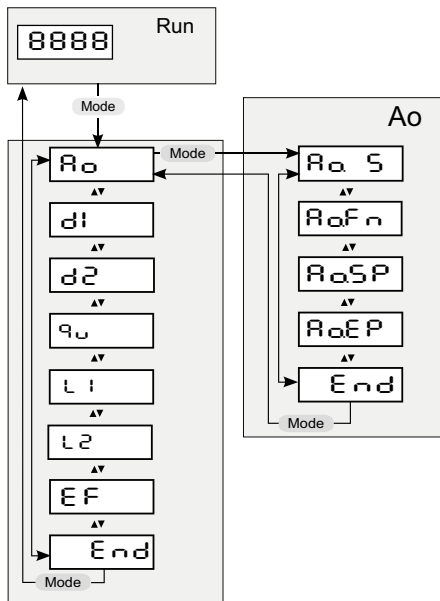

12.2 Switching output OUT 1

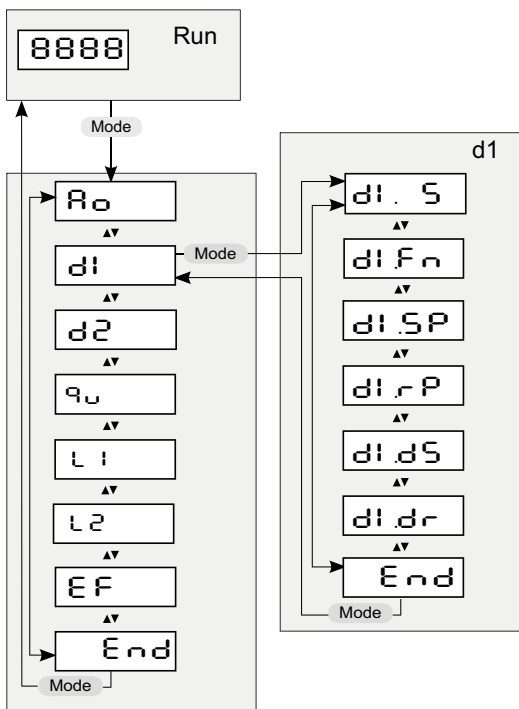

EN

12.3 Switching output OUT 2

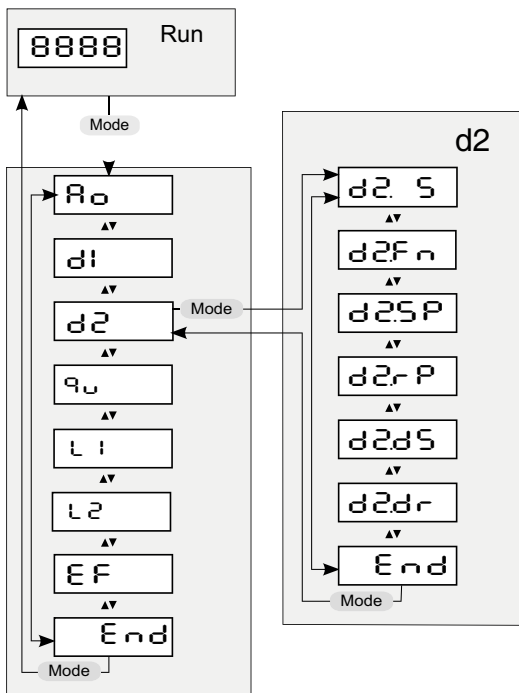

12.4 Two-colour channel

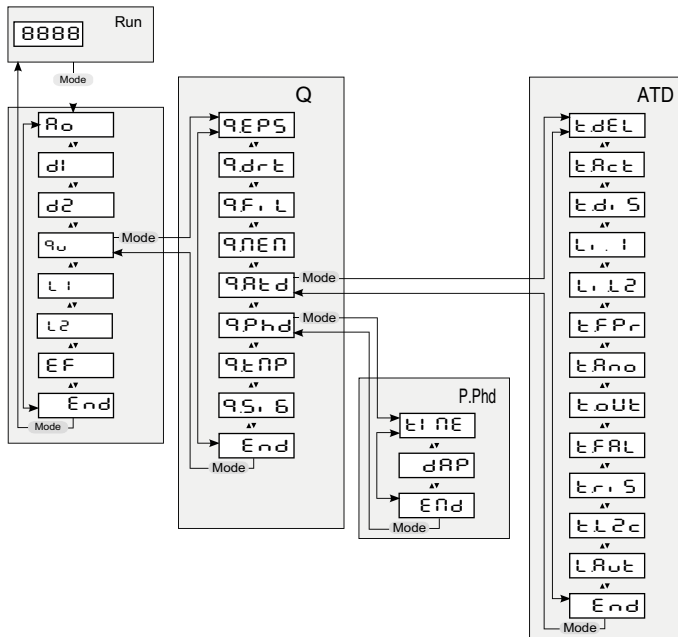

EN

P.Ph.d	Peak Hold Function Submenu only available when Peak hold function is active
ATD	ADT Function Submenu only available when ATD function is active

12.5 Spectral channel Lambda 1

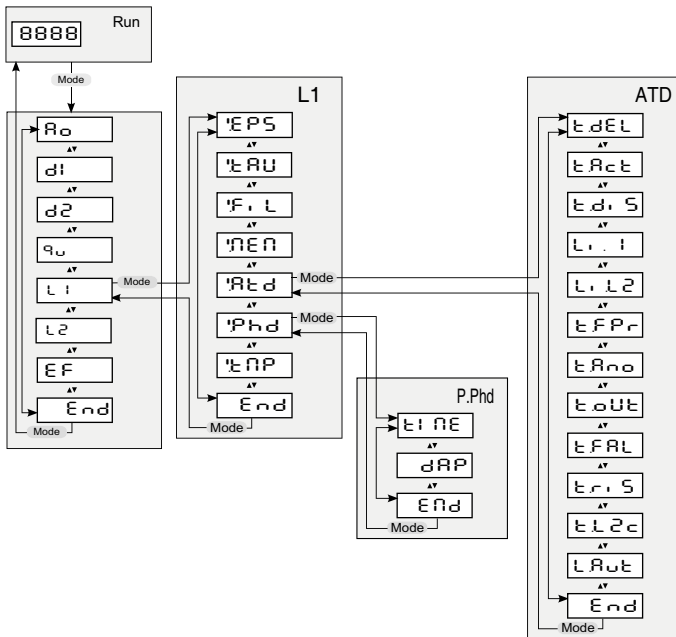

P.Ph.d	Peak Hold Function Submenu only available when Peak hold function is active
ATD	ADT Function Submenu only available when ATD function is active

12.6 Spectral channel Lambda 2

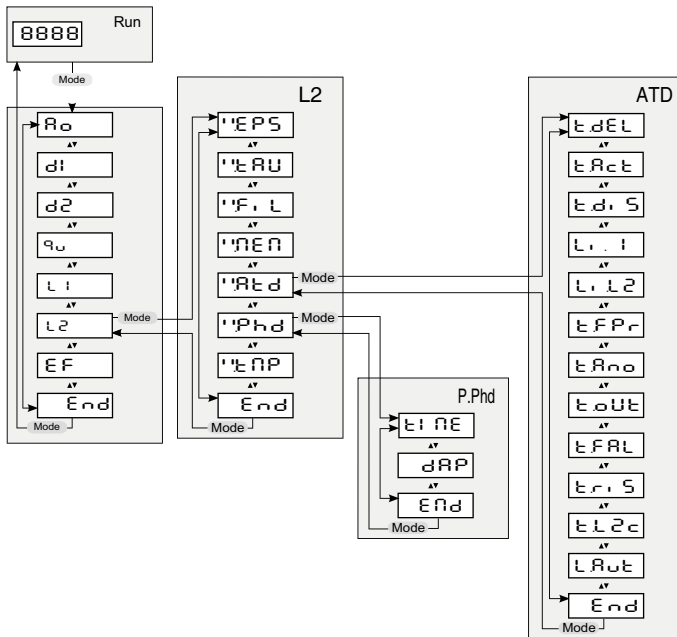

P.Ph.d	Peak Hold Function Submenu only available when Peak hold function is active
ATD	ADT Function Submenu only available when ATD function is active

12.7 Advanced Features

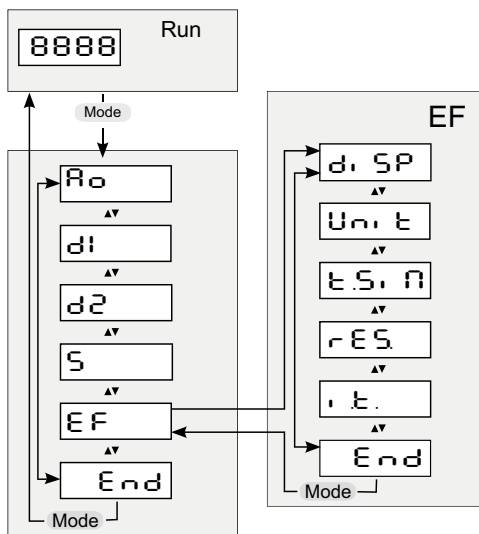

13 Menu explanation

13.1 Analogue output

Parameter	Function	Comments
R _o S	Select source	L 1 Lambda 1 one-colour mode L 2 Lambda 1 one-colour mode 9 two-colour mode
R _o F _n	0/4 – 20 mA	0 – 20 mA 4 – 20 mA
R _o S _P	Define lower limit of temp. span	
R _o E _P	Define upper limit of temp. span	
E _n d	End	Exit menu

EN

13.2 OUT 1 (d_i)

Parameter	Function	Comments
d _i S	Select source	L 1 Lambda 1 L 2 Lambda 1 9 two-colour mode R _L 1 A _T D tAct (λ1) R _L 1 t _r ATD Trig (λ1) R _L 2 A _T D tAct (λ2) R _L 2 t _r ATD Trig (λ2) R ₉ A _c ATD tAct (two-colour mode) R ₉ t _r ATD Trig (two-colour mode) d _i r dirt alert t _U internal device temperature
d _i F _n	Output function	h _{no} hysteresis function normally open h _{nc} hysteresis function normally closed F _{no} window function normally open F _{nc} window function normally closed

d1 SP	Lower threshold	
d1 rP	Upper threshold	
d1 dS	Switch-on delay	0 – 10 s, 0.1 steps
d1 dr	Switch-off delay	0 – 10 s, 0.1 steps
End	End	Exit menu

13.3 OUT 2 (d2)

Parameter	Function	Comments
d2 S	Select source	L 1 Lambda 1 L 2 Lambda 1 9 two-colour mode AL 1: ATD tAct (λ1) AL 1t: ATD Trig (λ1) AL 2: ATD tAct (λ2) AL 2t: ATD Trig (λ2) AA Ac ATD tAct (two-colour mode) AA tr ATD Trig (two-colour mode) d r dirt alert t U internal device temperature
d2Fn	Output function	hno hysteresis function normally open hnc hysteresis function normally closed Fno window function normally open Fnc window function normally closed
d2SP	Lower threshold	
d2rP	Upper threshold	
d2dS	Switch-on delay	0 – 10 s, 0.1 steps
d2dr	Switch-off delay	0 – 10 s, 0.1 steps
End	End	Exit menu

13.4 Two-colour channel (90)

Parameter	Function	Comments	
9EPS	Ratio correction	80... 120 %	
9drb	Pollution warning level	0.1 - 100	
9L.0	Relative lower limit, two-colour temperature reading invalid (signal intensity)	0.1 – 100 signal intensity	
9F.L	Smoothing time	0 - 999,9	
90EN	Memory function	OFF off Atd ATD function Phd Peak-Hold function	
9Atd**	Opening of the lower menu level ATD function**		
	tdEL	Time delay	See chapter ATD function
	tRct	Sampling time	
	td.S	Cut-off intervall	
	L. 1	Limit 1	
	L. 2	Limit 2	
	tFPr	Weighted average	
	tRno	Display mode	
	tOUT	Timeout	
	tFAL	Threshold for plausibility check: lower limit	
	tR.S	Threshold for plausibility check: upper limit	

EN

Parameter	Function	Comments
ε L 2 c	Check, whether threshold 2 is fallen below during the measuring time	See chapter ATD function
ε R U ε	Autoreset	
ε n d	Closing of the lower menu level ATD function	
9 P h d *	Opening of the lower menu level Peak-Hold function*	
ε . n ε	Hold time Peak-Hold function	Time in second
d R P	Damping	Damping
ε n d	Closing of the lower menu level Peak-Hold function	
9 ε n P	Actual temperature reading	The display shows the actual temperature reading.
9 S . 6	Signal-intensity	The display shows the actual calculated signal-intensity.
ε n d	End	Exit menu

* Parameter and lower menu level can only selected with active Peak-Hold function

** Parameter and lower menu level can only selected with active ATD function

13.5 Spectral channel (L 1) (L 2)

Parameter	Function	Comments
EPS	Emissivity	Correction of the radiation properties of the measured object (10...110%)
TRU	Transmission factor	When using protection shields, the value of the transmission of the used disk can be entered here.
FIL	Smoothing time	
MEM	Memory function	OFF Off PHLD Peak-Hold function ATD ATD function
ATD**	Opening of the lower menu level ATD Function**	
	TDL	Time delay
	TRC	Sampling time
	TDI	Cut-off interval
	L1	Limit 1
	L2	Limit 2
	WFA	Weighted average
	DMO	Display mode
	TOU	Timeout
	FLR	Threshold for plausibility check: lower limit
	URS	Threshold for plausibility check: upper limit

See chapter ATD function

EN

Parameter	Function	Comments
$\epsilon L 2 c$	Check, whether threshold 2 is fallen below during the measuring time	See chapter ATD function
$\epsilon n d$	Closing of the lower menu level ATD Function	
Phd^*	Opening of the lower menu level Peak-Hold Function*	
$\epsilon, n \epsilon$	Hold time Peak-Hold function	Time in sec.
dRP	Damping	Damping
$\epsilon n d$	Closing of lower menu level Peak-Hold Function	
$\epsilon n P$	Actual temperature reading	The display shows the actual temperatur reading
$\epsilon n d$	End	Exit menu

* Parameter and lower menu level can only be selected with active Peak-Hold Function

** Parameter and lower menu level can only be selected with active ATD function

13.6 Advanced Features (EF)

Parameter	Function	Comments
d. SP	Process value display	ON current temperature value OFF run is shown on the display
Unit	Temperature unit	Temperature displayed in °C or °F
ES. N	Temperature Simulation	A temperature can be simulated
RES	Factory settings	Reset to factory settings
it.	Internal device temperature	The display shows the actual internal device temperature reading
End	End	Exit menu





EN

* Parameter only available for models with camera

14 Parameterizing

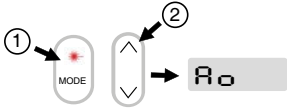
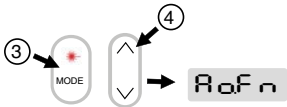
When you reset/adjust the operating parameters, the instrument remains in run mode. It continues to operate, using the current parameter settings, until you have finished configuring by pressing [MODE].

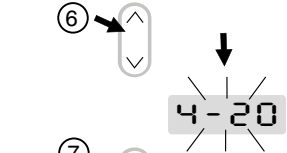
14.1 Setting parameters – general information

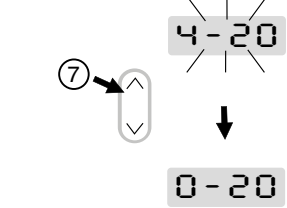
<p>1 Select main menu</p> <p>▶ Press [MODE] to access the main menu.</p>	
<p>2 ▶ Press [^ oder v] until the required output function or advanced features is displayed.</p>	
<p>3 Select parameter</p> <p>▶ Press [MODE].</p>	
<p>4 ▶ Press [^ or v] until the required parameter is displayed</p>	
<p>5 Change parameter value</p> <p>▶ Press [MODE].</p> <p>> Current parameter value is displayed.</p>	
<p>6 ▶ Press [^ or v] for 2 second.</p> <p>> >Display flashes three times.</p>	
<p>7 ▶ Press [^ or v] to change the parameter.</p> <p> ▶ Hold key [^ or v].</p> <p>> Numerical values scroll through rapidly.</p>	

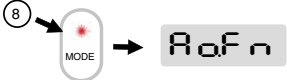
8	<p>Confirm parameter value</p> <ul style="list-style-type: none"> ▶ Press [MODE]. > The display indicates the parameter. The new value has been saved and will take effect. 	
<p>Exit operating parameter layer</p> <ul style="list-style-type: none"> ▶ Wait 30 seconds <p>or</p> <ul style="list-style-type: none"> ▶ Press [^ or v] to change to the parameter $E n d$. Then press [MODE] to change to the functional menu. ▶ In the functional menu press [^ or v] to change to the parameter $E n d$, then press [MODE]. 		

EN



If you press both keys [^ v] only briefly, you will exit the layer (ESC) function.

15 Error indications

Overload switching output	$S c$ and flashing of the LED Out 1/2
Overtemperature	Display off and the process value change with 0.5 Hz
Incorrect connection of supply voltage	The display is turned off
Supply voltage ≤ 16 V	The display is turned off
Temperature below measuring range	The display shows UL
Temperature above measuring range	The display shows OL

16 Service functions

16.1 Reset all parameters to factory settings

▶	[r E S] Select extended functions [E F] in the menu
▶	Press [MODE]
>	RES is shown in the display
▶	Press the v key for 2 s
>	RES flashed for 2 s
▶	Release the key v key and press it again
>	---- is shown in the display
▶	Press [MODE] button
>	The current temperature is shown in the display

16.2 Simulate a desired temperature

▶	[t S, n] Select extended functions [E F]
▶	Press [MODE]
>	The display shows the previously set temperature
▶	Press the ^ key for 2 s
>	Temperature flashes 3 times
▶	Use the keys ^ v to set the desired temperature, release the key
>	The display alternately shows t S, n and the temperature value
▶	Press [MODE] button
>	The display shows t S, n and the simulation is completed

Exit operating parameter layer

- ▶ Wait 30 seconds

or

- ▶ Press [^ or v] to change to the parameter End. Then press [MODE] to change to the functional menu.
- ▶ In the functional menu press [^ or v] to change to the parameter End, then press [MODE].

17 Maintenance

17.1 Cleaning the pyrometer lens

A soiled lens leads to wrong display of the measured value.

- ▶ Check the lens regularly and clean it, if required.
 - Remove dust by blowing or with a soft brush.
 - Use clean, soft and lint-free cloths or those offered on the market for lens cleaning.
 - For heavier contamination, use washing-up liquid or liquid soap. Then carefully rinse with clear water. Hold the lens downwards.
 - Exert only little pressure on the lens during cleaning to avoid scratches.

17.2 Replacing the protective screen

To protect the pyrometer optics against contamination in harsh industrial environments, an additional protective screen is often used. A contamination of the protective screen also leads to a reduced indication of the measuring value.

- ▶ Check the protective screen regularly and clean it if necessary or replace it in case of damage.
 - Remove dust by blowing or with a soft brush.
 - Use clean, soft and lint-free cloths or those offered on the market for lens cleaning.
 - For heavier contamination, use washing-up liquid or liquid soap. Then carefully rinse with clear water. Hold the lens downwards.
 - Exert only little pressure on the protective glass during cleaning to avoid scratches.

ATTENTION

Replacement of the protection glass only by authorized person. When removing the protective screen, always wear **protective glasses and -gloves**.

18 Models

Pyrometer		
Type	Temp. range	Application
PX 41 AF 1x	700 - 1800 °C	Metal, cement, lime, graphite, glass drops, crystal growth
	800 - 2400 °C	
	900 - 3000 °C	

19 Field of view

With a pyrometer with focusable optics, the size of the measurement field is determined by the distance ratio D . The measurement field diameter d at the focal distance is defined by the formula:

$$d = \frac{a}{D}$$

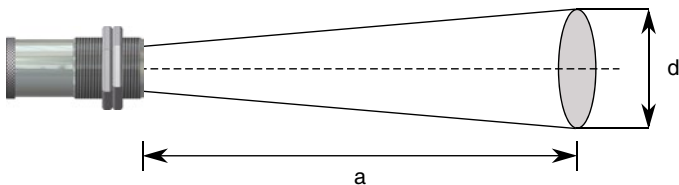

On our website you will find a measurement field calculator. Select the suitable pyrometer, enter the measuring distance and the length of the measurement field and you will get the suitable measurement field course and you can see the size of the measuring spot at the relevant distance.

<https://www.keller.de/en/its/tools/field-of-view-calculator.htm>

20 General technical data

Pyrometer	
Analogue output	0(4) -20 mA linear according NAMUR 43, switchable. scalable load 500 Ω
Switching output OUT1	PNP Open Collector outputs 24 V, ≤ 150 mA Switch point [$^{\circ}$ C]/ return switch [$^{\circ}$ C], hysteresis ≥ 2 K, on/switch-off delay, NC/ NO or IO-Link
Switching output OUT2	PNP Open Collector outputs 24 V, ≤ 150 mA Switch point [$^{\circ}$ C]/ return switch [$^{\circ}$ C], hysteresis ≥ 2 K, on/switch-off delay, NC/ NO
Ambient temperature	0 - 65 $^{\circ}$ C (basic unit) 0 - 250 $^{\circ}$ C (measuring head)
IO-Link revision	V1.1, download compatible to V1.01
SIO mode	yes, supported
Transmission rate	COM2 (38.400 Baud)
Storage temperature	-20 – 80 $^{\circ}$ C
Permissible humidity	95 % r.H. max. (non condensing)
Power supply	24 V DC +10 % / -20 % ripple ≤ 200 mV
Current consumption (without switching output)	≤ 150 mA
Housing material	Stainless steel
Weight	Approx. 1 kg
Connectivity	5-pin connection M12 (A coded)
Protection	IP 65 according DIN 40050 with screwed plug

Configuration parameter	Ratio correction 80 – 120 % Emissivity $\lambda 1, \lambda 2 \varepsilon$ 10 - 110 % Transmission factor $\lambda 1, \lambda 2$ Smoothing time t_{98} 0.1 – 999.9 s Peakhold Function 0.1 – 999.9 s ATD function
Sighting device	laser spot light
Dimensions	Ø 65 x 187 mm (basic unit without plug) Ø 30 x 67...86 mm (LWL measuring head M30) Ø 16 x 33...39 mm (LWL measuring head M16)

21 Device-specific technical data

PX 41 AF 11, AF 21, AF 22	
Temperature range	800 - 2400 °C
Sensor	Photodiode
Spectral sensitivity	0.95 / 1.05 µm
Focussing range	0,2 m - ∞ Optik (PA 41.01) M30 0,12 m - ∞ Optik (PA 41.05) M16 33 – 45 mm Optik (PZ 41.18) M16
Distance to target-size ratio	190:1 (PA 41.01) 100:1 (PA 41.05) 50:1 (PZ 41.18)
Resolution current output	0.2 K + 0.03 % of selected range
Resolution temperature reading	1 K
Response time t_{98}	Temperature range 800 -2400 °C ≤ 20 ms (T > 950 °C) Temperature range 900 -300 °C ≤ 20 ms (T > 1050 °C)
Measurement uncertainty	1.5 % (at $\epsilon = 1.0$ and $T_u = 23$ °C)
Repeatability	3 K
Temperature coefficient with reference to 23°C	≤ 0.05 %/K of temp. reading / K

EN

PX 41 AF 111, AF 121, AF 122	
Temperature range	900 - 3000 °C
Sensor	Photodiode
Spectral sensitivity	0.95 / 1.05 µm
Focussing range	0,2 m - ∞ optic (PA 41.01) M30 0,12 m - ∞ optic (PA 41.05) M16 33 – 45 mm optic (PZ 41.18) M16
Distance to target-size ratio	190:1 (PA 41.01) 100:1 (PA 41.05) 50:1 (PZ 41.18)
Resolution current output	0.2 K + 0.03 % of selected range
Resolution temperature reading	1 K
Response time t_{98}	Temperature range 800 -2400 °C ≤ 20 ms (T > 950 °C) Temperature range 900 -300 °C ≤ 20 ms (T > 1050 °C)
Measurement uncertainty	1.5 % (at $\epsilon = 1.0$ and $T_u = 23$ °C)
Repeatability	3 K
Temperature coefficient with reference to 23°C	≤ 0.05 %/K of temp. reading / K

PX 41 AF 211, AF 221, AF 222	
Temperature range	700 - 1800 °C
Sensor	Photodiode
Spectral sensitivity	0.95 / 1.05 µm
Focussing range	0.2 m - ∞ optic (PA 41.01) M30 0.12 m - ∞ optic (PA 41.05) M16 33 – 45 mm optic (PZ 41.18) M16
Distance to target-size ratio	110:1 (PA 41.01) 50:1 (PA 41.05) 36:1 (PZ 41.18)
Resolution current output	0.2 K + 0.03 % of selected range
Resolution temperature reading	1 K
Response time t_{98}	≤ 20 ms (T > 850 °C)
Measurement uncertainty	1.5 % (at $\epsilon = 1.0$ and $T_u = 23$ °C)
Repeatability	3 K
Temperature coefficient with reference to 23°C	≤ 0,05 %/K of temp. reading / K

PX 61 AF 21	
Temperature range	375 - 1200 °C
Sensor	Photodiode
Spectral sensitivity	1.5/ 1.9 µm
Focussing range	0.12 m - ∞ optic (PA 41.05) M16
Distance to target-size ratio	40:1 (PA 41.05)
Resolution current output	0.2 K + 0.03 % of selected range
Resolution temperature reading	1 K
Response time t_{98}	≤ 30 ms
Measurement uncertainty	1.5 % (at $\epsilon = 1.0$ and $T_u = 23\text{ °C}$)
Repeatability	3 K
Temperature coefficient with reference to 23°C	≤ 0.05 %/K of temp. reading / K

22 Accessories

A range of mechanical and electrical accessories are available for mounting the pyrometers in industrial environments.

For the selection of the components use the following link:

<https://www.keller.de/en/its/pyrometer/accessories>

23 Default settings

The default settings can be found in the descriptions of the IODD. You can find them on the respective device pages on our homepage www.keller.de/en/its/pyrometer

24 Copyright

The licence information of the Open Source libraries used can be found in the media center on our homepage www.keller.de/en/its

Copyright prohibits the reproduction or distribution of this instruction manual, including text, photographs or images contained herein, in whole or in part, for any purpose whatsoever, without prior consent of the author. This applies to any form of mechanical or electronic reproduction as well as to electronic transmission in any form through any medium.

Please note:

Unless otherwise stated in this instruction manual, the instruments described herein are subject to change without prior notice, particularly modifications for the sake of technological advancement.

© 2020 KELLER HCW GmbH
Carl-Keller-Straße 2-10
D-49479 Ibbenbüren-Laggenbeck
Germany
www.keller.de/its

