

Pyrometer CellaTemp **PA 1x, 2x, 3x**

Mat. No.: 101 3020 01/2026



Copyright prohibits the reproduction or distribution of this instruction manual, including text, photographs or images contained herein, in whole or in part, for any purpose whatsoever, without prior consent of the author. This applies to any form of mechanical or electronic reproduction as well as to electronic transmission in any form through any medium.

Please note:

Unless otherwise stated in this instruction manual, the instruments described herein are subject to change without prior notice, particularly modifications for the sake of technological advancement.

© 2010 – 2026 KELLER HCW GmbH
Carl-Keller-Straße 2 - 10
D-49479 Ibbenbüren
Germany
www.keller.de/its/

Contents

1	Miscellaneous	1
1.1	Information about this manual	1
1.2	Explanation of symbols.....	1
1.3	Liability and Warranty.....	1
1.4	Copyright.....	2
2	Safety	2
2.1	Intended use	2
2.2	User's responsibility.....	3
2.3	Safety requirements	3
2.4	Electromagnetic Compatibility	3
2.5	Safety instructions and protective measures	3
2.5.1	Laser radiation	3
2.5.2	Position of the product label.....	4
3	General Description.....	5
4	Operating Controls and Display	7
5	Quick Reference Guide	8
5.1	PA Connector Pin Assignment	8
5.2	Power Requirement 24 V DC	8
5.3	Current Outputs 0/4 - 20mA.....	9
5.4	Switching output.....	9
6	Getting Started	10
6.1	General installation tips	10
6.2	Pyrometer Alignment to Target.....	10
6.3	Pyrometers with laser sighting.....	11
6.4	Pyrometer with camera.....	12
6.5	Setting parameters at the pyrometer (basic configuration).....	12
6.6	Setting Emissivity	13
6.7	Output current range	14
7	Functioning of the pyrometer	15
7.1	Internal signal processing.....	15
8	Configuration and Setup	15
8.1	Signal Conditioning	15
8.1.1	Emissivity and Transmittance	15
8.1.2	Ambient Temperature Compensation	16
8.1.3	Temperature offset using linear interpolation	17
8.1.4	Signal Smoothing Filter.....	17
8.1.5	Min/Max Data	18
8.2	I/O Configuration	22
8.2.1	Selectable current output range.....	22
8.2.2	Digital outputs	23
8.2.3	Function „Level“	25
8.2.4	Range” Function.....	26
8.2.5	Digital inputs.....	27
8.2.6	Analogue input for emissivity correction or ambient temperature compensation	27
8.3	General functions	28
8.3.1	Green Status LED	28
8.3.2	Activate Laser	28
8.3.3	Video camera settings.....	28
8.4	Simulate current signals for analogue output Ao1 and Ao2	29
9	Setting Parameters at the device.....	30
9.1	Configuration layers.....	30
9.1.1	Temperature measurement via spectral channel 1	30
9.1.2	Configuration I/O	32
9.1.3	General Functions.....	34

9.1.4	Displayed temperature readings	35
9.1.5	Simulated current signal for outputs Ao1 and Ao2	35
10	CellaView software	35
11	Installation of the USB driver.....	36
12	How to operate the pyrometer with the CellaView software	37
12.1	CellaView via USB point-to-point connection	37
12.2	CellaView via RS485 point-to-point connection	37
12.3	CellaView via RS485 bus connection	39
12.4	Termination of RS485 bus.....	41
13	Operation of the pyrometer via terminal program	41
13.1	Serial Data Transmission of Temperature Data	42
13.2	Terminal connection via USB	43
13.3	Terminal connection via RS485.....	43
14	User calibration / scaling of the current output	45
14.1	Calibration/scaling via CellaView	46
14.2	Calibration/scaling via terminal connection	46
15	Shielding and Grounding	48
15.1.1	Potential equalisation	48
16	Connectivity Examples.....	50
16.1	Connection to VK 02/A Cable	50
16.2	Connection to DA 230 digital display unit.....	50
17	Theory of Non-Contact Temperature Measurements	51
17.1	Advantages of Non-Contact Temperature Measurement.....	51
17.2	Measurements at Black Bodies (Cavity Radiators)	51
17.3	Measurements of Real Radiators	52
17.4	Emissivity Coefficient Table PA 10	53
17.5	Emissivity Coefficient Table PA 20 – PA 30.....	54
18	Maintenance	55
18.1	Cleaning the pyrometer lens.....	55
19	Type overview	56
20	Technical Data PA 10.....	57
20.1	Field of View Diagrams for PA 10	58
21	Technical Data PA 13.....	59
21.1	Field of View Diagram for PA 13.....	60
22	Technical Data PA 15.....	61
22.1	Field of View Diagrams for PA 15	62
23	Technical Data PA 17.....	63
23.1	Field of View Diagram for PA 17	64
24	Technical Data PA 18.....	65
24.1	Field of View Diagram for PA 18.....	66
25	Technical Data PA 20.....	67
25.1	Field of View Diagrams for PA 20	68
26	Technical Data PA 28.....	70
26.1	Relation to the ambient temperature and the emissivity	71
26.2	Field of View Diagram for PA 28.....	71
27	Technical Data PA 29 (150 ... 800 °C).....	72
27.1	Field of View Diagram for PA 29.....	73
28	Technical Data PA 29 (180 ... 1200 °C).....	74
28.1	Field of View Diagrams for PA 29	75
29	Technical Data PA 29 (250 ... 2000 °C, 350 ... 2500 °C)	77
29.1	Field of View Diagrams for PA 29	78

30	Technical Data PA 30	80
30.1	Field of View Diagrams for PA 30	81
31	Technical Data PA 35	84
31.1	Field of View Diagrams for PA 35	85
32	Technical Data PA 38 AF 10	88
32.1	Field of View Diagram for PA 38.....	89
33	Dimensions	90
34	Technical data camera	91
35	Transmission values of protective glasses	93
36	Accessories	94
36.1	Mounting angle PA 11/K.....	95
36.2	Polarising filter PA 20/P.....	96
36.3	Mounting bracket PA 11/U.....	97
36.4	ZnS Window PA 10/I	98
36.5	Quartz window PA 20/I and sapphire window PA 15/I	98
36.6	Cable VK 02/A.....	99
36.7	Cable VK 02/F	100
37	Mounting combinations	101
37.1	Mounting combination PA 20-007	101
37.2	Mounting combination PA 20-010.....	102
38	Glossary	103
39	Shipping, Packaging and Disposal	104
39.1	Inspecting your shipment.....	104
39.2	Packaging	104
39.3	Disposal of used apparatus	104
40	Copyright	105
41	Default settings	106
41.1	Temperature measurement via spectral channel	106
41.2	Configuration I/O	107
41.3	General Functions	108

1 Miscellaneous

1.1 Information about this manual

The purpose of the Operating Manual is to provide the user with all necessary information to be able to install the pyrometer and any necessary accessories.

Before starting installation, be sure to read and understand this entire manual, in particular the chapter on safety! The instructions contained in this manual, especially those concerning safety, as well as site-specific regulations governing UV radiation must be complied with at all times!

1.2 Explanation of symbols

Important safety-related references in this manual are marked with a symbol.

Attention

This symbol indicates important information which, if neglected, might result in pyrometer damage, malfunction or breakdown.



CAUTION

This symbol points out guidelines which should be followed for efficient and trouble-free operation.



Action

This symbol indicates the result of the action taken

1.3 Liability and Warranty

All information compiled in this manual is in accordance with applicable regulations. The statements made are based on state-of-the-art technology and reflect our extensive knowledge and many years of experience.



Always carefully read this Operating Manual before beginning any work on or with the instrument, especially prior to installation and initial setup! The Manufacturer shall not be held liable for any damages or malfunctions arising from a disregard of the warnings and instructions contained herein

This Operating Manual must be retained for future use. Please ensure that all persons who wish to operate the instrument have access to this manual.

1.4 Copyright

This Operating Manual should be treated as confidential. It is solely intended for use by people involved with the instrument. This manual may not be made available to a third party without prior Manufacturer's consent. Please contact the Manufacturer if the need should arise.



The data, texts, charts, drawings, images or other representations contained in this manual are copyright-protected and furthermore, subject to intellectual property rights. Violators will be prosecuted. Unauthorized use and copyright infringement will be subject to penalty by law.

Reproductions of any kind, in whole or in part, as well as the exploitation or disclosure of this manual's content without the explicit written approval of the Manufacturer are expressly prohibited by law. Violations shall be subject to compensation claims by the Manufacturer. The right to claim additional indemnities remains reserved.

2 Safety

This chapter outlines all important safety aspects to be considered for optimum employee protection and to ensure safe and reliable operations.

2.1 Intended use

The pyrometer is solely intended for non-contact measurement of temperatures as described in this manual. Any other use is not intended. Operational safety can only be ensured when the instrument is used for its intended purpose.

Attention

It is prohibited to use the pyrometer for any other purpose beyond what is specified in this manual. Using the instrument in any other manner will be considered as improper.

The manufacturer is only liable for damage that occurs during correct use. The prerequisite for any liability, however, is that the cause of the damage is due to a defective product and the defect in the product was caused by the manufacturer.

2.2 User's responsibility

The pyrometer may only be used when it is in perfect working condition.

2.3 Safety requirements

- ▶ Read this document before using the device.
- ▶ Ensure that the product is fully suitable for the relevant applications.
- ▶ Do not try to open the module enclosure. There are no users-serviceable components inside.
- ▶ Do not use and disable the product if it is damaged.
- ▶ Do not use the product if it operates incorrectly.

2.4 Electromagnetic Compatibility

The devices comply with the essential safety requirements of the Electromagnetic Compatibility Directive 2014/30/EU (EMC Act).

When connecting a power supply unit, make sure that it also conforms to these standards. Radio interference may arise if the pyrometer is interconnected with such peripheral devices which have not been properly interference-suppressed. This may necessitate additional interference suppression measures.

2.5 Safety instructions and protective measures



2.5.1 Laser radiation

Attention

Laser class II product, according to IEC 60825-1:2014

- ▶ Do not stare into the laser beam.
- ▶ Only switch on the laser to align the pyrometer and then switch it off again.
- ▶ Do not leave the device unattended when the laser is activated.
- ▶ Do not point the device's laser beam at people.
- ▶ When installing and aligning the pyrometer, avoid reflections of the laser beams from reflective surfaces.
- ▶ Do not look directly into the laser with optical tools (for example, binoculars, telescopes, microscopes).
- ▶ Observe the latest version of the applicable laser safety regulations.

2.5.2 Position of the product label

	 <p>Wavelength: 630 - 680 nm Power: < 1 mW The arrow on the laser warning sign points in the direction of the laser's exit lens.</p>
	<p>If the pyrometer is installed in such a way that the laser warning sign is covered, the enclosed laser warning sign (1 piece) must be attached to the mounting or machine next to the laser beam exit opening (so that the laser is not visible when reading the sign).</p>

3 General Description

The CellaTemp PA Series provides efficient, microprocessor-controlled pyrometers for non-contact temperature measurements.

The field of applications for CellaTemp PA 1x includes temperature detection of materials such as synthetic materials, rubber, textiles, paper, coated sheet steel, wood or varnish within a range from 0 °C to 1000 °C.

The CellaTemp PA 13 is specially designed to detect the temperature of objects in flame-heated furnaces. Because PA 13 works at a narrow spectral range of 3.9 µm, water vapour and CO₂ in the detector's field of view will not influence the measurement, even at greater target distances. The spectral sensitivity of this model enables highly accurate and reliable measurements through flames and combustion gases. This pyrometer can also tackle other atmospheric challenges such as reducing the effect of background radiation within.

The PA 15 was specifically developed for temperature measurements of glass. Glass is transparent in the visible spectral range and in the near infrared range. Its emissivity depends on the wavelength, the type and the thickness of the glass. In the range of 4.5 - 8 µm glass has an emissivity of almost 100%. Above 5 µm, atmospheric influences, such as humidity or water vapour, affect the measurement. The CellaTemp PA 15 is equipped with a blocking filter a spectral sensitivity of 4.6 - 4.9 µm. The measurement is taken near the surface and is not influenced by the change of thickness, the types of glass, or varying moisture contents in the atmosphere.

The PA 17 is used for measuring hot CO₂ combustion gases for example in waste processing plants, incinerators, coal power plants and other combustion furnaces. The PA 18 measures at a specific wavelength, where hot, organic combustion gases have a high optical density and therefore good radiation properties.

The CellaTemp PA 28 and PA 29 were designed with a special band-stop filter and sensor which ignore interfering IR radiation from sources such as daylight or laser beams. CellaTemp PA 28 and PA 29 feature a response spectrum which is far less sensitive to incidental light reflections from nearby hot objects than most commonly available pyrometers which are responsive at short wavelengths.

The spectral pyrometers PA 2x and PA 3x are used for temperature measurements from 250 °C to 2000 °C or 500 °C to 2500 °C, respectively. Their applications cover large segments of the iron and steel

producing industry and the metal, glass, ceramics and chemical industries.

To indicate the exact measurement spot, CellaTemp PA features through-the-lens sighting or, as an alternative, laser sighting or an integrated camera.

The instruments have rugged stainless-steel housings which make them ideal for use in hostile industrial environments. PA pyrometers are splash waterproof according to IP65 (DIN 40050)

All PA pyrometers with through-the-lens sighting feature an interchangeable, focusable lens. Through-the-lens sighting with target marker facilitates easy alignment to the target. PA instruments with laser sighting feature an integrated laser which produces a laser dot image on the target object to indicate the precise measurement spot.

CellaTemp PA 1x features dynamic signal filtering known as a “smoothing function”. This provides a steady signal and allows the pyrometer to respond quickly when the temperature of the targeted surface fluctuates erratically.

The adjustable emissivity factor makes it easy to adapt the pyrometer to the specific radiation characteristics of the particular material measured.

All pyrometers of the PA series have two analogue current outputs; each is switchable from 0 - 20 mA to 4 - 20 mA.

The output currents are linear to the measured temperature. The required temperature range can be set at the pyrometer.

When ambient temperatures are higher than the admissible working temperature, the output current is > 20.5 mA.

CellaTemp PA also features an analogue voltage input which can be used as an alternative to current output 2. The emissivity factor or a correction for reflected ambient temperature can be controlled using this voltage input.

Two serial interfaces (USB and RS485) are available. They enable the user to change all operating parameters such as emissivity setting, temperature range, smoothing function or output current range during running operations.

CellaTemp PA allows for continuous temperature data output in a user-configured cycle time.

4 Operating Controls and Display

The rear panel of the CellaTemp PA has a 4-digit display and 3 push-buttons. The display shows the current temperature or, during configuration using the pushbuttons, the display will show the corresponding parameter.

Whenever the display shows a parameter, the F1 Parameter LED (yellow) will light up. The function of the F2 Status LED (green) is user configurable. In its initial state when supplied to the customer the F2 LED indicates status for the switch able output Do1 as ready for operation.

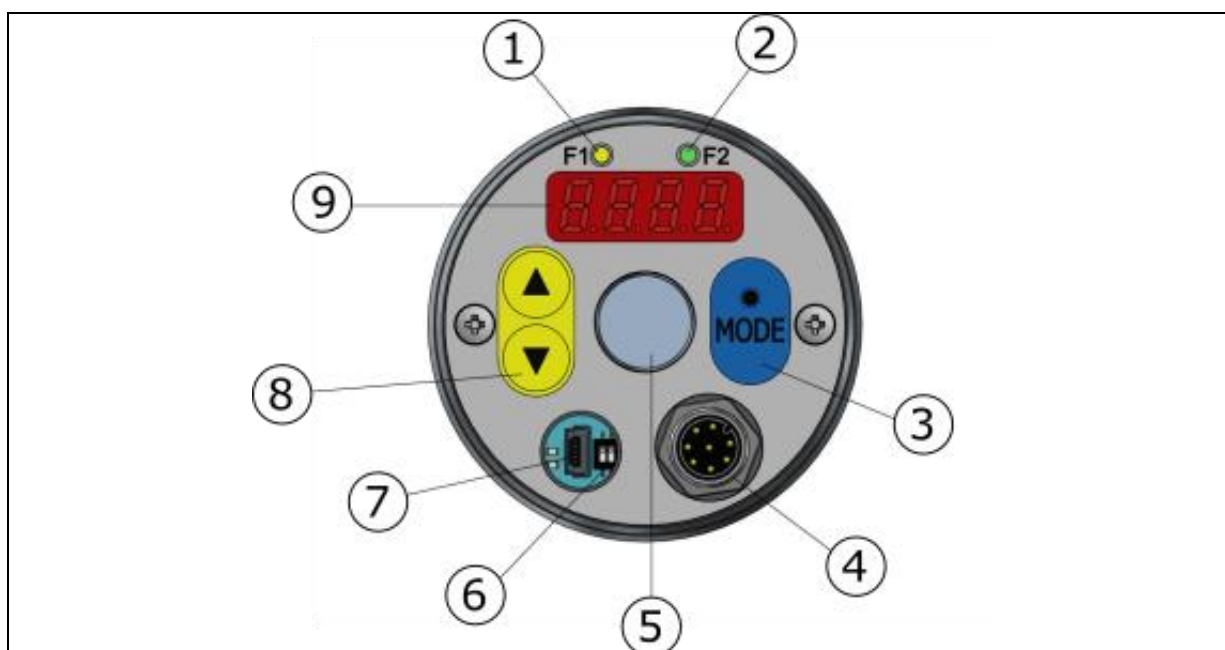

1	Parameter-LED
2	Status-LED
3	Mode-key (switch for laser target marker)
4	Connector socket
5	Depending on the type: through-the-lens viewfinder, laser pilot light or camera
6	DIP switch for termination of the RS485 connection
7	USB-port
8	Select / change parameters
9	Display

5 Quick Reference Guide

5.1 PA Connector Pin Assignment

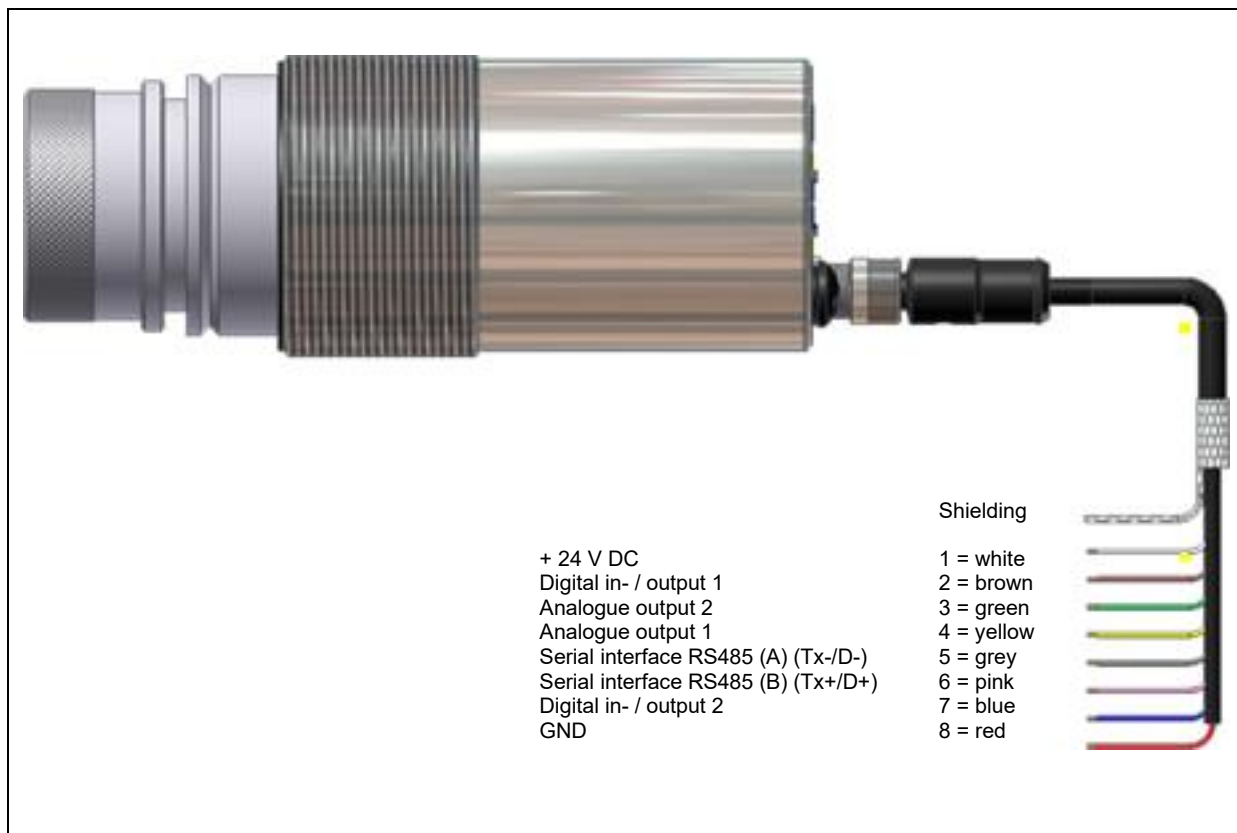

Attention

The pyrometer housing is connected to the signal ground via a $0.1\mu\text{ F}/50\text{V}$ capacitor. Isolate any unused wires to avoid the display of erroneous data

5.2 Power Requirement 24 V DC

The instrument works with an operating voltage of 24 V DC. The voltage required for operation must be supplied by a separate power supply. This power supply unit must conform to directive DIN IEC 61010.

The supply voltage is $\leq 135\text{ mA}$ for standard design, $\leq 150\text{ mA}$ for models with laser sighting and $\leq 175\text{ mA}$ with camera. CellaTemp PA is equipped with inverse polarity protection. The output currents and voltages share one ground connection via pin 8 of the connector.

A self-test is performed when the instrument is switched on. The display will briefly indicate the software version and after that the emissivity setting. When the self-test is completed, the pyrometer is ready for operation, and the display will show the current temperature reading.



To achieve a high degree of measurement accuracy and repeatability it is important to allow the pyrometer time to warm up. Turn the power supply on about 10 minutes before starting (camera version 20 min).



We recommend that you protect the feed line to the pyrometer against short circuit by using a 250-mA micro fuse.

5.3 Current Outputs 0/4 - 20mA

CellaTemp PA features two current outputs. Both outputs are active current sources which supply linear output current. The user can select between two scales: either 0 - 20 mA or 4 - 20 mA. Maximum load is 500 Ω .

The two current outputs are factory preset to 4 - 20 mA!

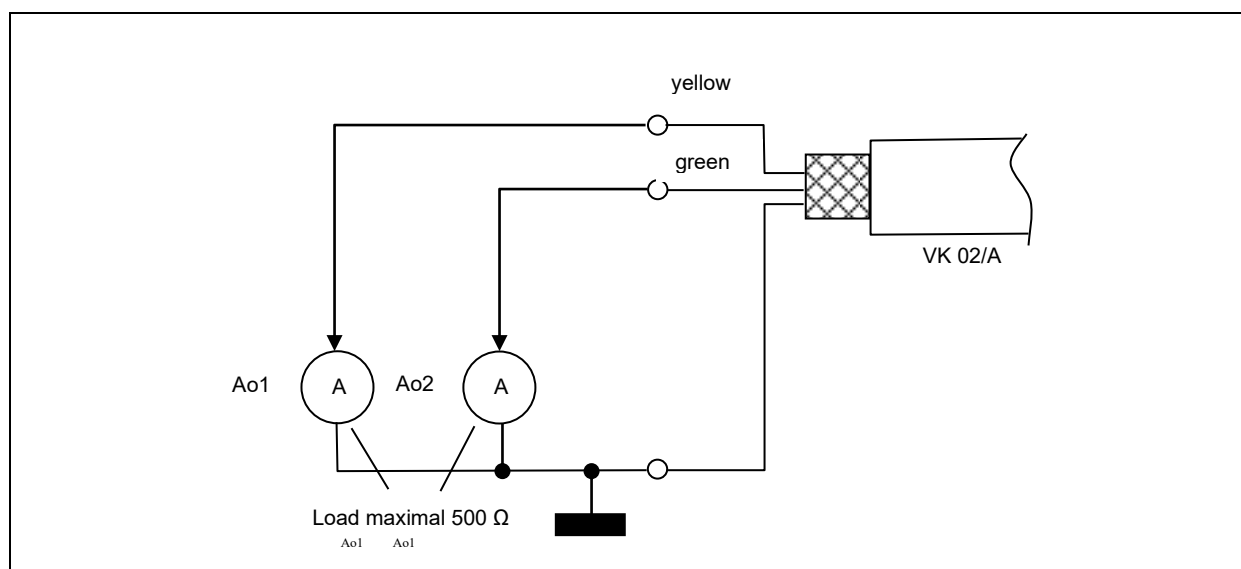

For all pyrometers of the PA series the current outputs are short-circuit-proof and share one ground connection via pin 8 of the connector. Each current output can be individually scaled and can be set either at the display or via interface.

When only one current output is required, Output 1 should be selected (Pin 4)

5.4 Switching output

All pyrometers of the PA Series feature two switching outputs which can be configured as digital outputs or digital inputs. The open collector outputs allow for a voltage of +24 V DC. For signal processing a pull-down resistor can be applied to the ground connection of the supply voltage. The maximum current of each open collector output is 30 mA.

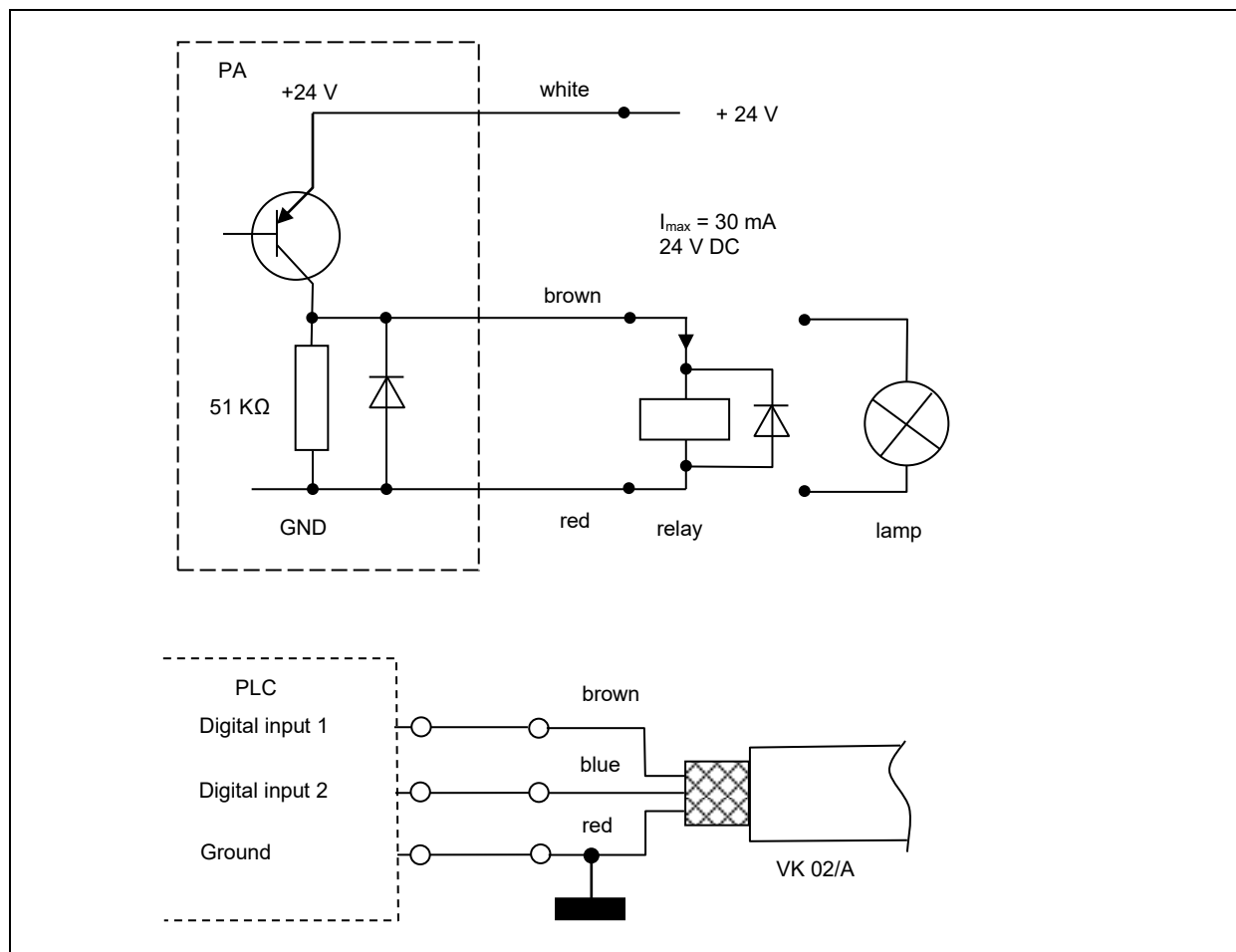

See Chapter 8.2.2 for more information configuration.

6 Getting Started

6.1 General installation tips

Install the pyrometer in a location where it will not be unnecessarily exposed to smoke, ambient heat or water vapour.

A false reading (too low) will be displayed when the pyrometer lens is dirty. Therefore, always ensure that the lens is clean.

The pyrometer's optical path must remain unobstructed. Any interference or obstacle may lead to measurement errors.

6.2 Pyrometer Alignment to Target

For accurate temperature measurement, it is essential that the pyrometer is correctly aimed and focused on the target object. Make sure that the optical path is not obscured because this would most likely impair accuracy.

When aiming the pyrometer with through-the-lens sighting to a target, both the targeted object and the target marker (distinctly marked circled spot in the viewfinder) must appear in sharp focus simultaneously. The measured object must completely fill the target circle in the viewfinder.

A variable polarising filter is available to provide eye protection. This accessory can be screwed to the ocular lens to provide adjustable brightness control.

If the actual target spot is the same size as the minimum spot size required by the distance-to-target ratio, or only marginally larger, then we recommend that you check the maximum output current to verify proper focussing.

6.3 Pyrometers with laser sighting

The pyrometer models PA xx AF xx /L feature a laser spotlight which can be activated to facilitate instrument alignment to the target spot.

Under normal operating conditions the laser will be off. To activate the laser, press the MODE button on the rear panel for 2 seconds. Alternatively, the laser can be switch on via switching input or PC. The laser will automatically deactivate after 1- 15 minutes.

The pyrometer should be aimed and focused on such a way that—at the proper distance to the target object—the laser beam produces razor-sharp round dot to indicate the exact measurement spot.



For pyrometers featuring an integrated laser spotlight, the light may, when activated, influence the instrument's temperature reading. This influence will vary, depending on the instrument model and the temperature. To ensure an accurate and reliable temperature reading, the laser spotlight will automatically deactivate after 1- 15 minutes. The time is adjustable.

6.4 Pyrometer with camera

The model's PA xx AF xx /C features an integrated camera.

The video feed simplifies the optical alignment of the pyrometer and allows for continuous observation of the measuring point.

When aiming the pyrometer focus the sensing head until the video image is sharp. (Technical data see chapter 34)

6.5 Setting parameters at the pyrometer (basic configuration)

Use the buttons ▲ ▼ and the „MODE" button on the rear panel to access and configure parameters. With these buttons you can view and adjust all settings required for operating the pyrometer. (See Chap. 3.1).

Menu structure:

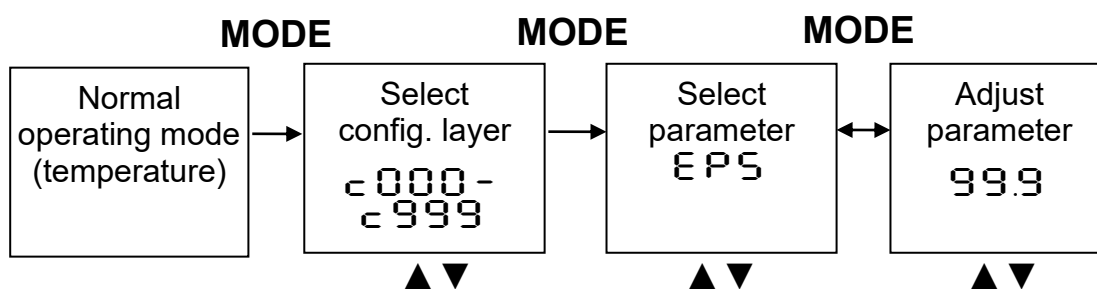

1. Press the MODE button while in normal operating mode to switch to "configuration layer" mode.
2. Use ▲ ▼ to select the configuration layer for the parameter you wish to set.
3. Press MODE to confirm. Press ▲ ▼ to select the particular parameter.
4. Press MODE to confirm. Press ▲ ▼ to adjust the parameter value.
5. Press MODE again to end. Press ▲ ▼ to select E n d / S R U E .
6. Now use MODE to either apply the changes you have made to the settings [S R U E] or to close without saving these changes [E n d]. After that, the display panel will resume showing the temperature reading.

Parameter	configuration layer	Explanation
EPS. 1	c 00 1	Emissivity spectral channel 1 (see chapter 6.6).

Ao 1.1	c 0 10	Lower limit of temperature span analogue output Ao1(see chapter 6.7).
Ao 1.2	c 0 10	Upper limit of temperature span analogue output Ao1(see chapter 6.7).
Ao 1.4	c 0 10	Hardware configuration of the analogue output 0 - 20 mA, 4 - 20 mA (see chapter 6.7).
Ao 1.5	c 100	Temperature measurement simulation to verify signal transmission



Key lock may have been activated via interface. When selecting the configuration layer you will be prompted to enter an access code with P 0000. To obtain full access to parameter settings, enter P 1000 otherwise you will only be able to view parameters but not change them.

6.6 Setting Emissivity

A pyrometer measures temperature by detecting the radiant energy emitted from an object's surface in the form of electromagnetic waves. The temperature reading not only depends on the intensity of the object's thermal radiation (how hot the object is), but also on the material's particular surface characteristics and thus its specific ability to emit thermal energy. This is called emissivity. To obtain an accurate temperature reading, it is imperative that the pyrometer be adjusted for this emissivity prior to measurement.

Set the emissivity correction at configuration layer c 000 1. See the Emissivity Coefficient Table in Chapter 12 to select the proper emissivity factor for your application. We recommend that you first perform a comparison temperature measurement with another device to determine the correct emissivity factor for the task.



During normal operating mode, emissivity can be set at the pyrometer using the ▲ ▼ buttons. When simultaneously pressing the MODE key, the display shows the current measuring temperature while the emissivity coefficient continues to be adjusted in the background. This is an easy way to determine the emissivity when the object temperature is known. The modified values are directly adopted

! Attention

Once you have configured the emissivity parameter, the pyrometer will maintain this specific setting. The pyrometer will always operate with this value unless you change the setting.

6.7 Output current range

For the pyrometer's two analogue current outputs, select the current loop scale – (0 - 20 or 4 – 20 mA)—which matches that of the downstream signal processing equipment (PLC, display device, controller, etc.). At the pyrometer and at the controller, set the upper and lower limits of the temperature range and the current loop output signal. Access this setting using configuration layer $\square \square \square \square$.

7 Functioning of the pyrometer

7.1 Internal signal processing

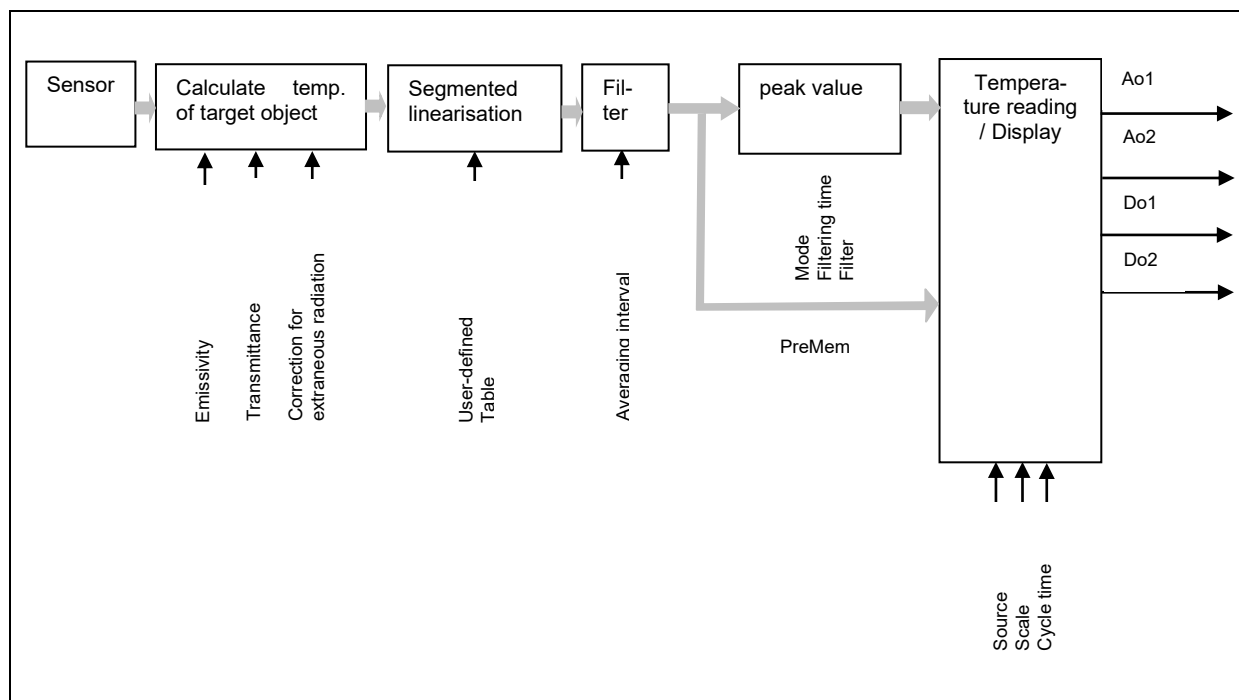

8 Configuration and Setup

8.1 Signal Conditioning

8.1.1 Emissivity and Transmittance

Besides the emissivity correction (mentioned in Chapter 5.5), a pyrometer must be adjusted for the transmission properties of any supplementary lens and/or protective window screwed onto the pyrometer. Set the pyrometer for the specific transmission factor (a percentage value) which is indicated either in the product's data sheet or on the lens itself. This is parameter t_{RU} and can be accessed at configuration layer c_{00} . If you are not using any auxiliary lens or protective window, set the parameter to 100.0. A Listing of the transmission values of the used glasses you find in chapter transmission values of protective glasses.

8.1.2 Ambient Temperature Compensation

Under normal conditions, CellaTemp PA should produce highly accurate temperature readings once you have set the emissivity and transmittance factors. Certain conditions, however, will require that you make an additional correction. Object surfaces which have very low emissivity will reflect thermal radiation from their surroundings. If your target object is in surroundings which are hotter than the target itself, and the infrared radiation coming from extraneous sources reflects off the object, the sensor will collect this additional energy. To ensure that the measurement is not distorted and that temperature readings are completely accurate, you should activate „Ambient temperature compensation“ (switch on $\epsilon \square \square \text{ : } / \text{ b R c . i })$

Now enter the temperature value of the ambient source of radiation and its influence as a percentage. You will have to determine these variables first.

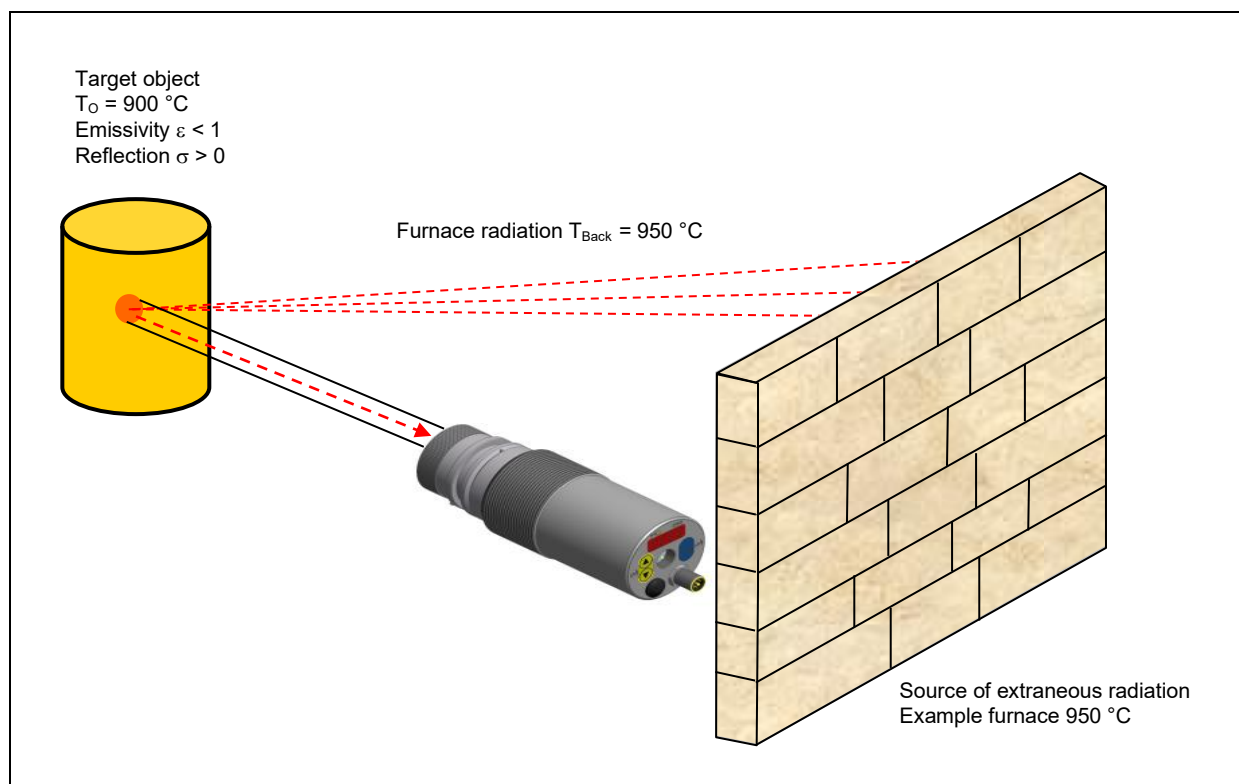

8.1.3 Temperature offset using linear interpolation

When necessary, CellaTemp PA allows you to program an offset for the temperature reading reported. The offset correction can be configured individually with a minimum of 2 and a maximum of 10 interpolating points (X/Y nodes). This information is stored in a user-defined temperature-indexed lookup table and used for signal conditioning. For values lower than the 1st node and higher than the last node, the first and last linear segments are extrapolated. Enter the nodes in ascending order. Use the rear panel display to access this function via $\square \square \square \mid / \square \square \square \mid$.

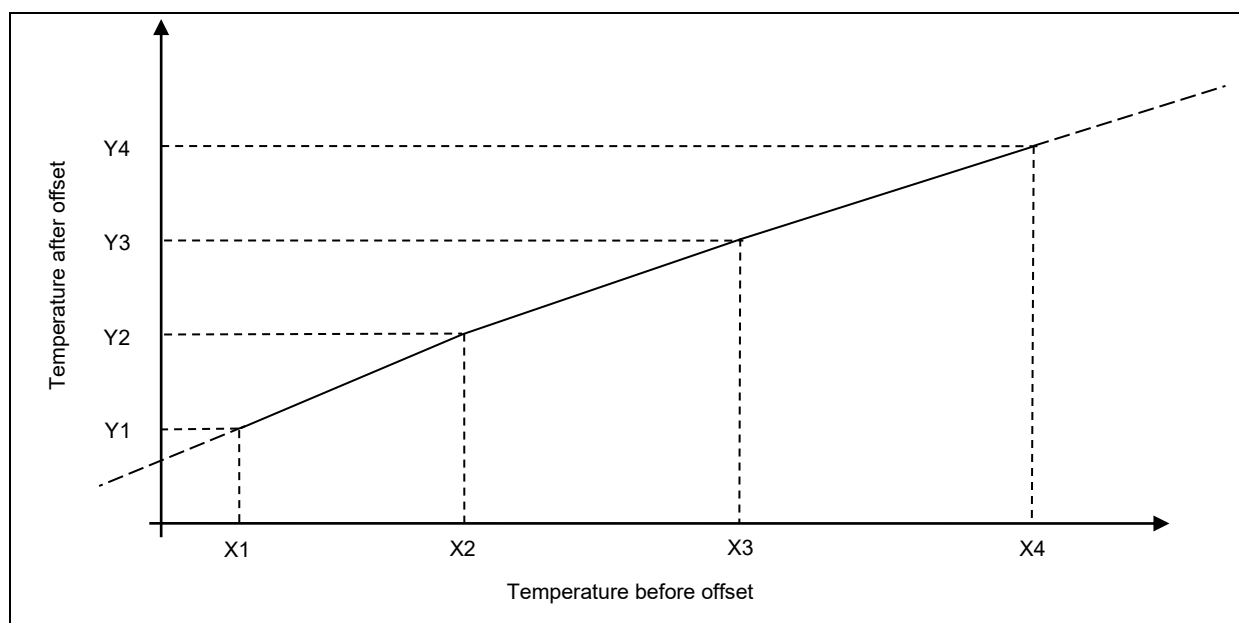

8.1.4 Signal Smoothing Filter

When the target object's temperature is erratic, it makes sense to smooth these temperature fluctuations in order to stabilize the signal. The greater the time constant t_{98} , (user definable), the lower the effect of these fluctuations on the yielded temperature reading. The pyrometer's response time is proportional to the time constant. Set signal smoothing via parameter $\square \square \square \mid / F \mid \square \mid$. CellaTemp models PA 10/13 which have a thermopile sensor also feature „automatic averaging“. The averaging interval. This facilitates a steady measurement, on the one hand, and enables fast response times on the other hand when temperatures become erratic. This function is activated as a default setting.

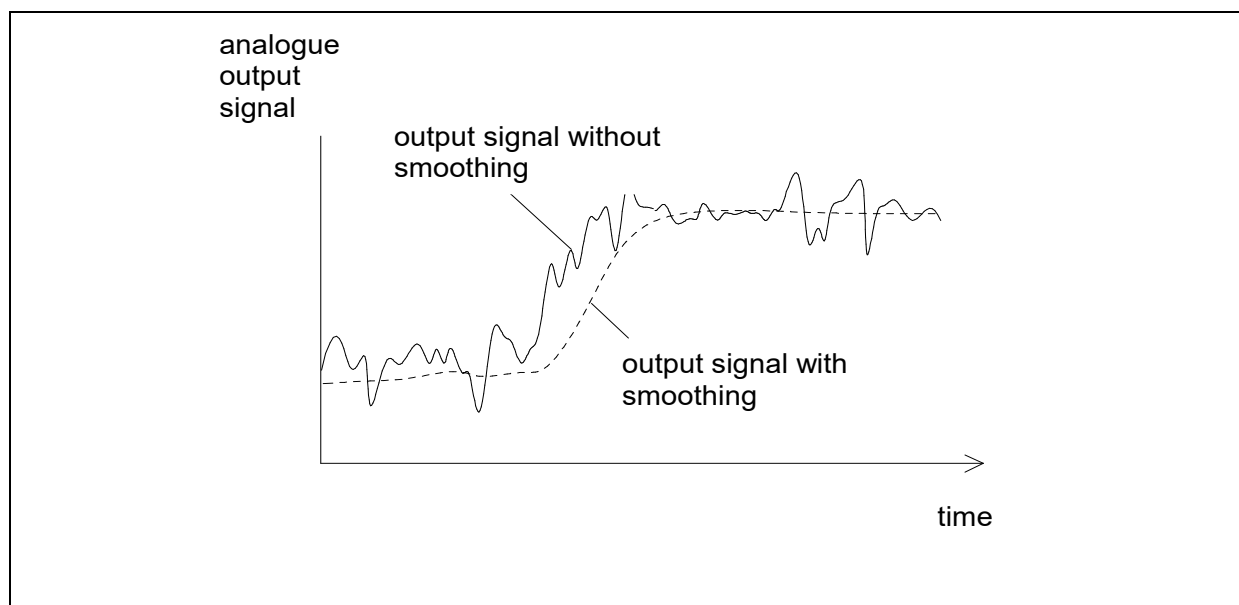

8.1.5 Min/Max Data

CellaTemp PA features data memory to store minimum and maximum (peak) temperature readings. This feature can be configured in one of the following modes:

- Memory off
- Store minimum value (single)
- Store maximum value (single)
- Store double max. value for cyclical processes
- ATD function (Only available in pyrometer with ATD function)

Select and activate one of these memory modes for Spectral Channel 1 (L1) and configure as described below. The calculated temperature value can be shown on the rear panel display and/or transmitted to the current output for further processing.

Min/Max Memory

In this mode—also called peak picker—the pyrometer determines the highest or lowest temperature reading and keep the temperature reading. As an option, one of the switching inputs can be configured to reset the min/max memory and to define the smoothing filter setting.

Double Maximum Memory withhold time

It might often be desirable to determine the peak temperature during a defined time period, for example when the objects to be measured move past the pyrometer, resulting in temperature readings which would appear to be cyclical. In this mode, the displayed temperature reading will

not drop between targeted objects. The peak temperature reading will be held for a preset period.

Configure a hold time between 0.01 to 999 sec. either from your PC terminal or using the pyrometer's rear panel buttons. The maximum temperature sampled during the defined hold time will be saved. This value is transmitted to the signal output. In mid-sequence-- after 50% lapse of the hold time—a second internal peak picker starts. When the hold time has expired, the output signal decreases to the value of the second peak temperature (if it turned out being lower than the first peak). It makes sense to choose a hold time which is approximately 1 ½ times as long as the cycle of the moving targets. This ensures that a temperature measurement gap is avoided and temperature changes are detected quickly.

As an option, one of the switching inputs can be configured to reset the min/max memory and to define the smoothing filter setting.

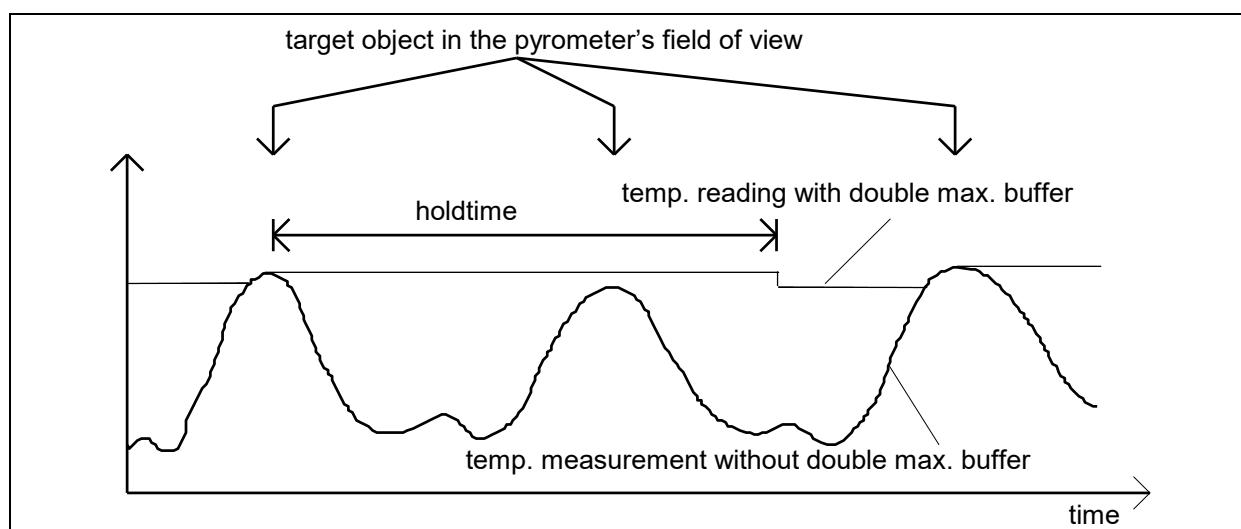

Automatic temperature detection (ATD) function **

This function serves to automatically detect the temperature during manufacturing processes with discontinuous or intermittent material flow. First, define the sampling time and the upper and lower temperature limits. These limits or thresholds define the temperature range within which you wish to detect the temperature. It is also possible to determine the average temperature value over the course of multiple measuring cycles.

The start of a measuring cycle is determined automatically and is dependent on the following variables.

Limit 1 (L . 1)	Before beginning the measurement, the temperature reading must have been lower than Limit 1 at least once. If Autoreset (A.r S t = 0) the limit 1 will be ignored
Limit 2 (L . 2)	Limit 2 must be exceeded at least for the duration of the time delay (t . d E L).
Time Delay (t . d E L):	See above

When the conditions are fulfilled, the sampling time will begin. (t . A c t).

Sampling time (t . A c t)	During the sampling time the temperature is detected and stored as a temperature value.
----------------------------------	---



If the parameter $t . A c t = 0$ the algorithm of the ATD function will detect automatically the end of the discontinuous process. At the parameter $t . A c t$ is shown "auto" instead of the time.

The configuration of the Normal Display Mode (A n o) determines which temperature value is saved during sampling.

Display mode (A n o)	„t=0“ displays the lower temperature range limit during the measurement. „t . h L d“ indicates the previous temperature reading during the current measurement.
-----------------------------	---

As an option, the green Status LED can light up, or the digital output can be used to indicate sampling.

When the sampling time has ended, an average value is calculated for recorded measuring cycles. The temperature reading is weighted with the previously saved average value and added.

Weighted average (F - P r)	Factor for average weighting. If you choose 100%, averaging will be off.
--------------------------------------	--

The smaller you set the F - P r factor, the stronger the weighting will be. When the averaging function is activated (F - P r < 100%) a plausibility check will be performed. The difference in temperature between the current reading and the previously stored average is established. If the dif-

ference is higher than the plausibility threshold $\pm SP$, the transmitted data will be „0“ and the average value will remain unchanged.

Plausibility ($\pm SP_{-}$)	Threshold for plausibility check: lower limit which is acceptable for a valid measurement.
--------------------------------------	--

Plausibility ($\pm SP_{+}$)	Threshold for plausibility check: upper limit which is acceptable for a valid measurement.
--------------------------------------	--

When sampling is completed, the average temperature value or „0“ will be output. At the same time, an impulse is generated which can be used for the digital outputs. Enter R_{t} as the source and set the hold time to 0.5 s.

A cut-off interval (time lag) begins after the sampling time has ended. This cut-off interval must expire before the next measurement can start with the cycle starting conditions described above.

Cut-off interval ($t_{d,5}$)	The interval between one completed sampling and the start of a new sampling.
--	--

If a measuring cycle does not start during the period t_{out} , the saved average will be deleted and reinitialized when the next cycle begins.

Timeout (t_{out}):	Time cycle for deleting average value (in minutes)
-------------------------------	--

Activate auto reset for the ATD function to run cyclically. Limit 1 will then be ignored. Measurement continues when the Limit 2 is exceeded for the period configured with t_{dEL} .

Auto reset (R_{r5t}):	Auto reset on/off
----------------------------------	-------------------

If, during the measurement, the temperature reading falls below Limit 2, the measurement will be dismissed.

Set Li2 check on tAct (t_{hL2})	on/off
--	--------

** Function available upon separate order

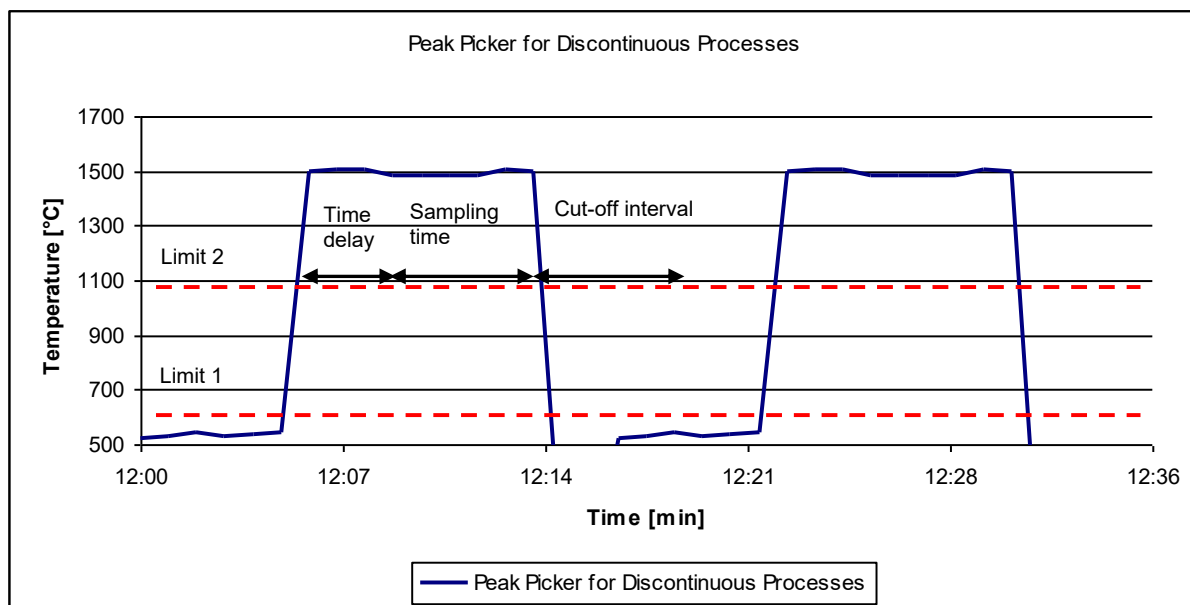

8.2 I/O Configuration

8.2.1 Selectable current output range

You will need to define the current loop scale and define a source for an analogue output signal. For a spectral pyrometer the source for analogue output Ao1 is:

- Spectral channel 1

In the normal operating mode, Spectral channel 1 will be shown on the display.

The second analogue output Ao2 offers additional the following option:

- Spectral channel 1 temperature before Min/Max memory
- Internal device temperature

Configure the scale of each of the two analogue outputs separately. Define the temperature span by adjusting the upper and lower limits of the measuring range. Select either 0 – 20 mA or 4 – 20 mA as the current output range. The temperature to current conversion is linear.

The desired current output range of either 0 – 20 mA or 4 – 20 mA can be configured as an absolute setting. Alternatively, the current range can be coupled to the specific voltages of Switching Output 1 or 2.

- 0 V -> 0—20 mA
- 24 V -> 4—20 mA

Make these settings in configuration layer $\epsilon 0 10$ with parameters $R_{0 1.5}$, $R_{0 1.}$, $R_{0 1.}$ und $R_{0 1.4}$ for analogue output 1, and in the same manner for analogue output 2.

Configuration example PA 10:

Ao1: temperature reading of spectral channel 1
0 - 1000 °C \equiv 4 - 20 mA

Ao2: internal device temperature
0 - 100 °C \equiv 4 - 20 mA

It is also possible to configure analogue output 2 with a sub-range which covers a portion of the temperature span assigned to analogue output 1:

Configuration example PA 10:

Ao1: temperature reading of spectral channel 1
0 - 1000 °C \equiv 4 - 20 mA

Ao2: temperature reading of spectral channel 1
200 - 400 °C \equiv 4 - 20 mA

8.2.2 Digital outputs

One of the following functions can be assigned to each of the digital outputs:

- **Deactivate** (This is required when you want to use the digital output as digital input).
- **Status LED** lights up to indicate that the temperature reading of spectral channel 1 lies within the pyrometer's available temperature range.
- **Limit switch** with adjustable signal threshold, relating to spectral channel 1, min/max of spectral channel 1, or inner device temperature as the signal source.
- **Limit switch** with adjustable signal threshold:
 - Spectral channel 1
 - Min/Max spectral channel 1
 - Device temperature
- **Status Signal ATD** function.
 - Triggered by ATD function spectral channel 1 at the end of the measuring time
 - ATD function spectral channel 1 indicate the measuring time

When the digital output is to be used as a limit switch, you can configure the following parameters:

- Signal source
- Signal function and direction
- Limit and hysteresis at function = „Level“
- Lower / upper limit at function = “Range”
- Delay time
- Hold time

8.2.3 Function „Level“

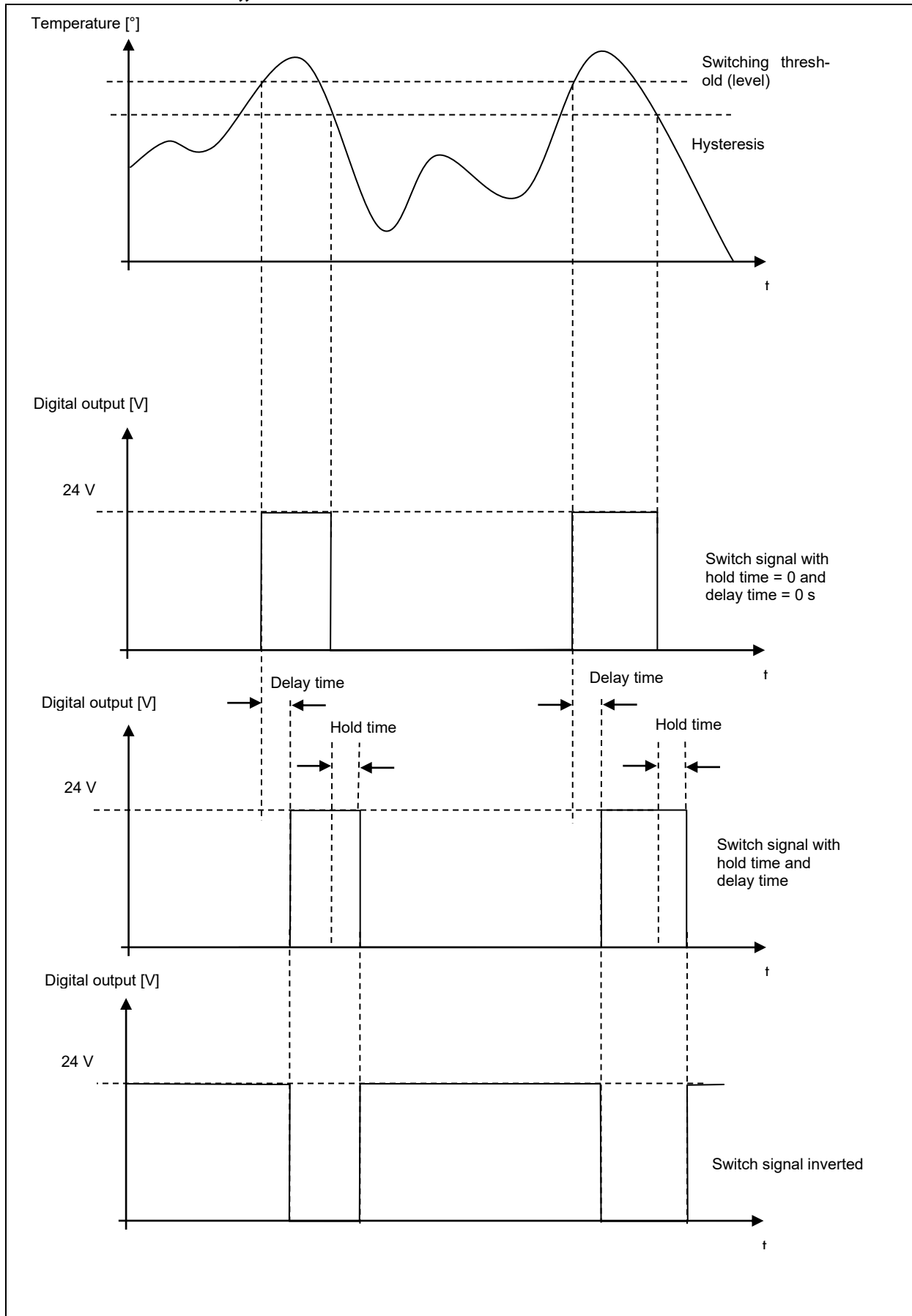

8.2.4 Range" Function

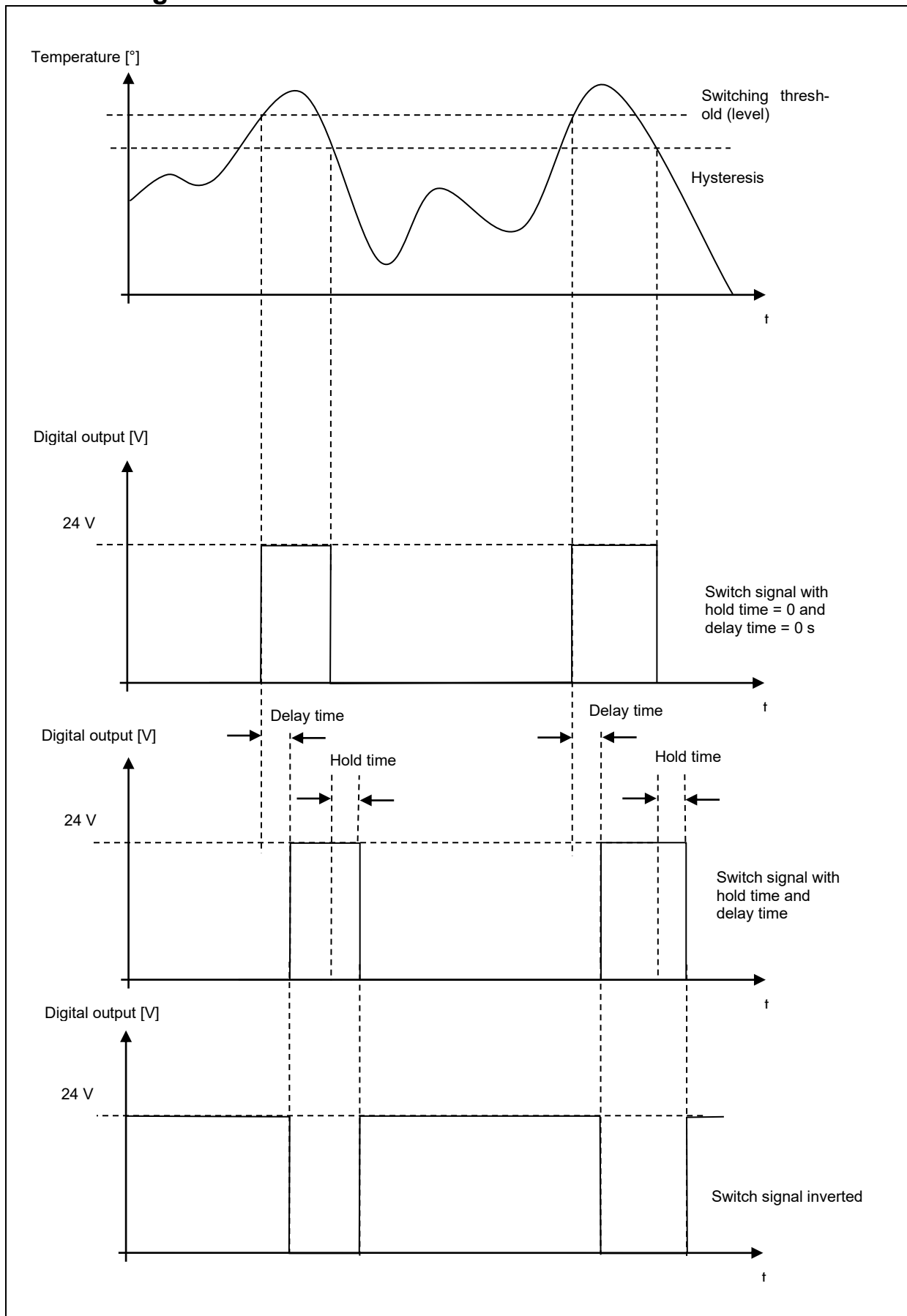

8.2.5 Digital inputs

If you want to use the digital output as an input, you must first manually deactivate the digital output and configure the following parameters:

- Select a current output range (either 0 – 20 mA or 4 – 20 mA) for Ao1/Ao2
- Delete the temperature readings in Min/Max or DoubleMax
- Define whether the laser will be event-triggered. This only applies to models with built-in laser.

8.2.6 Analogue input for emissivity correction or ambient temperature compensation

When desired, current output 2 (Pin 3) can function as a voltage input. Target object emissivity can be configured from another remote device. Alternatively, the input signal can be used to define the temperature of reflected radiation from surroundings for the ambient temperature compensation function.

First, manually deactivate current output 2. Then select one of these two correction functions at configuration layer $\text{c} \rightarrow \text{I} \rightarrow \text{A} \rightarrow \text{Fn}$.

When this is activated, it will not be possible to configure the emissivity setting or the ambient temperature compensation using the rear panel buttons, nor will it be possible to change the settings from a PC. The pyrometer display will alternate between showing the currently used value and showing EHE to indicate that these parameters were set from an external source.

Define the upper and lower voltage values using parameter $\text{A} \rightarrow \text{U}$. Set the input variables using parameter $\text{A} \rightarrow \text{U}$.

Example for setting emissivity:

```

A .U 1 = 0 V
A .U 2 = 10 V
A .U 1 = 0 (Epsilon 0 %)
A .U 2 = 100 (Epsilon 100 %)

```

Example for configuring the ambient temperature compensation function:

```

A .U 1 = 2 V
A .U 2 = 10 V
A .U 1 = 700 (temperature 700 °C)
A .U 2 = 1200 (temperature 1200 °C)

```



If the analogue input is used, the parameters for analogue output 2 are not accessible. If analogue output 2 is active, the parameters from the analogue input are not available.

8.3 General functions

The parameter of the general function you find at configuration layer `c 0 1 1`.

8.3.1 Green Status LED

You can assign specific functions to the LED:

- LED is continuously lit to indicate 24 V operating voltage
- LED indicates status of switching output 1
- LED indicates status of switching output 2
- LED indicates ATD function in progress

Set the function using parameter `L E d 5`.

8.3.2 Activate Laser

If your CellaTemp PA features a built-in laser, there are several ways in which it can be activated. Configure parameter `P 1 L 0` with the method you have selected:

- Activate using button on rear panel
- Permanently off
- Edge-triggered: based on signal input (0 -> 24V transition)



Do not attempt to operate the laser continuously. The built-in laser is not designed for continuous use. When the user-defined laser auto-shutoff time is reached (maximum programmable duration = 15 minutes) the laser will automatically switch off. When the ambient temperature exceeds 55°C the laser will automatically deactivate.

8.3.3 Video camera settings

Pyrometer models with an integrated video camera feature the following operating modes.

Target Brightness Control (TBC) settings

- Exposure control only applies to the measurement area. (`c t b c = on`)
- Exposure control applies to the entire field of view. (`c t b c = off`)

As a standard, the target brightness control feature works in the target area to show bright objects against a dark background or dark objects against a bright background with an ideal brightness.

White Balance

White balance basically means colour balance. It is a function which gives the camera a reference to "true white" — it tells the video camera what the colour white looks like, so the camera will record it correctly. Since white light is the sum of all other colours, the camera will then display all colours correctly. If the video camera does not find a neutral reference, it might produce an image with a colour imbalance. (setting `c.c.o.L = „Automatic“`).

The video camera can compensate for ambient illumination conditions. The camera's light sensitivity adapts dynamically to the brightness of the actual target object captured within the rectangular measurement area.

The user can manually select the colour temperature of the light source. In that case the video camera will not perform automatic white balance `c.c.o.L = DAYL` (daylight).

Superimposed Temperature Reading

The current temperature reading can be superimposed on the video camera's image. Use the setting `c.o.u.L` to select or deselect this function.

8.4 Simulate current signals for analogue output Ao1 and Ao2

CellaTemp PA features a function to simulate a temperature reading. This is especially useful after initial setup to verify that temperature data is correctly transmitted to the controller. Use the pushbuttons on the pyrometer rear panel to simulate a temperature reading, which is applied as an output current signal scaled to the selected current range. The appropriate parameter can be accessed via configuration layer `c.100`. If the pyrometer is set up correctly, the downstream controller should indicate the values you have entered (only within the scaled range). If there is a discrepancy, please check the current range scale or the cable connection. When you have completed the function test, exit by pressing "E S c" and return to normal operating mode.

9 Setting Parameters at the device

In addition to the configuration possibilities described in Chapter 7, many parameters can be adjusted at the rear panel using push buttons. These settings can be accessed via configuration layers.

9.1 Configuration layers

The configuration layers are structured as follows:

- `c 00 1` Temperature measurement via spectral channel 1
- `c 0 10` I/O Configuration
- `c 0 11` General functions
- `c 020` Display temperature readings
- `c 100` Simulated current signal for outputs Ao1 and Ao2

The following chart lists all parameters. Certain parameters will be suppressed at the rear panel display if the prerequisite function is deactivated. For example: the smoothing time cannot be configured when signal smoothing is not activated.

9.1.1 Temperature measurement via spectral channel 1

(configuration layer: `c 00 1`)

Parameter	Function	Explanation
<code>EPS. 1</code>	Emissivity factor L1	See Chap. 8.1.1
<code>tRU. 1</code>	Transmission factor L1	See Chap. 8.1.1
<code>bAc. 1</code>	Ambient temperature compensation	See Chap. 8.1.2
<code>bAc.t</code>	Temperature of ambient source of radiation	
<code>bAc.!</code>	Influence of ambient IR radiation	The reflected thermal radiation from the surroundings as a portion of the total IR radiation collected by the sensor in %
<code>L.in. 1</code>	Temperature offset using linear interpolation	<code>oFF</code> off <code>z - 10</code> : number of nodes used
<code>L.H 1</code>	node x 1 - 10	Signal input (initial value) node n
<code>L.Y 1</code>	node y 1 - 10	Signal output (resulting value) node n
<code>F.L. 1</code>	Smoothing filter	<code>oFF</code> smoothing not activated <code>o n</code> simple smoothing <code>RUt o</code> subsequent smoothing (only model PA1x)
<code>F.L.t</code>	Smoothing time	time t98 in second. For simple smoothing
<code>MEM. 1</code>	Min/Max memory	<code>oFF</code> off <code>n n</code> lowest (min.) temperature, single <code>n n n</code> highest (max.) temperature, single <code>dbL n</code> double maximum

		ATD function in process
HELT	Hold time for Min/Max	Hold time in sec.
FILN	Smoothing filter for min/max *	OFF off ON on
FILT	Smoothing time*	Time t98 in sec.
CLRN	external delete for Min/Max memory*	OFF no external deletion EXT1 delete when 0-24V for switching output 1 EXT2 delete when 0-24V for switching output 1
EDEL	time delay**	For ATD-function, see Chap. 8.1.5
ERCT	meas. time active**	For ATD-function, see Chap. 8.1.5
EDIS	cut-off interval**	For ATD-function, see Chap. 8.1.5
TOUT	timeout**	For ATD-function, see Chap. 8.1.5
L1	Limit 1**	For ATD-function, see Chap. 8.1.5
L2	Limit 2**	For ATD-function, see Chap. 8.1.5
F-P	Average weighting**	For ATD-function, see Chap. 8.1.5
ESP-	Threshold plausibility**	For ATD-function, see Chap. 8.1.5
ESP-	Threshold plausibility**	For ATD-function, see Chap. 8.1.5
ANO	Mode of display**	EQ show lower limit of temp. range during running measurement HLD Hold previous temp. reading during running measurement
ARST	Autoreset**	For ATD function, see Chap 8.1.5
CHL2	Set Li2 check on tAct	For ATD function, see Chap. 8.1.5
SAVE	Save	Save changes / exit menu
ESC	Escape	Discard changes / exit menu

* Only available with Min/Max and Double Max modes

** Only available with ATD function



L1 stands for Lambda 1, meaning the temperature reading from spectral channel 1

9.1.2 Configuration I/O (configuration layer: $\epsilon \ 0 \ 10$)

Parameter	Function	Explanation
Ro1S	Ao1 select source	$\lambda 1$ Spectral channel 1
Ro1L	Ao1 define lower limit of temp. span	
Ro1U	Ao1 define upper limit of temp. span	
Ro14	Ao1 - 0/4 - 20mA	0-20 0 - 20 mA 4-20 4 - 20 mA EH1.1 digital input 1: 0V=0-20mA 24V=4-20mA EH1.2 digital input 2: 0V=0-20mA 24V=4-20mA
Ro2.	Analogue output 2	OFF off ON on
Ro2S	Ao2 select source	$\lambda 1$ Spectral channel 1 $\lambda 1Pr$ Lambda 1 without peak picker λU inner device temperature
Ro2L	Ao2 define lower limit of temp. span	
Ro2U	Ao2 define upper limit of temp. span	
Ro24	Ao2 - 0 / 4 - 20mA	0-20 0-20mA 4-20 4-20mA EH2.1 Switch. input 1: 0V=0-20mA 24V=4-20mA EH2.2 Switch. input 2: 0V=0-20mA 24V=4-20mA
do1.	Switching output 1	OFF off ON on
do1S	Do1 select source	$r dY$ Status LED indicates 'ready' $\lambda 1$ Lambda 1 $\lambda 1Pr$ Lambda 1 without peak picker λU Internal device temperature ATD Triggered by ATD function Lambda 1** $Meas$ Measuring time ATD Lambda 1**
do1F	Do1 function	λUL Switch direction "Level" (output active if limit excess) $\lambda UL-$ Switch direction "Level" / output inverted $r nS$ Switch direction "Range" (output active if limit excess) $r nS-$ Switch direction "Range" / output inverted
do1t	Do 1 switching threshold	Switching threshold (only available at function "Level")
do1h	Do1 signal threshold	Hysteresis +/- relative to signal threshold (only available at function "Level")
do1L	Do1 lower limit of range	Lower limit of range for switch signal (only available function "Range")
do1U	Do1 upper limit of range	Upper limit of range for switch signal (only available function "Range")
do1L	Do1 delay time	See Chap. 8.2.2
do1H	Do1 Hold time	See Chap. 8.2.2
do2.	Switching output 2	OFF off ON on

do2S	Do2 select source	<ul style="list-style-type: none"> r d S Status LED indicates 'ready' l 1 Lambda 1 l 1 P r Lambda 1 without peak picker t u Internal device temperature o b r : Triggered by ATD function Lambda 1** R R c : Measuring time ATD Lambda 1**
do2F	Do2 function	<ul style="list-style-type: none"> l u l . Switch direction "Level" (output active if limit excess) l u l . - Switch direction "Level" / output inverted r n b . Switch direction "Range" (output active if limit excess) r n b - Switch direction "Range" / output inverted
do2t	Do 2 switching threshold	Switching threshold (only available at function "Level")
do2h	Do2 signal threshold	Hysteresis +/- relative to signal threshold (only available at function "Level")
do2_.	Do2 lower limit of range	Lower limit of range for switch signal (only available function "Range")
do2.-	Do2 upper limit of range	Upper limit of range for switch signal (only available function "Range")
do2L	Do2 delay time	See Chap. 8.2.2
do2H	Do2 Hold time	See Chap. 8.2.2
A .F n	Analogue input function	<ul style="list-style-type: none"> o F F Analogue input deactivated E P S. Emissivity for Lambda 1 via analogue input t R c t. Temp. ambient radiation via analogue input
.u 1	Analogue in upper and lower voltage values	Define lower limit of voltage for input voltage (0 - 10V)
R .u 2	Analogue in upper and lower voltage values	Define upper limit of voltage for input voltage (0 - 10V)
R .u 1	Analogue in upper and lower input variables	Input of lower voltage value (example 80% for emissivity)
R .u 2	Analogue in upper and lower input variables	Input of upper voltage value (example 100% for emissivity)
S R u E	Save	Save changes / exit menu
E S c	Escape	Discard changes / exit menu

** Only available with ATD function



Ao1 and Ao2 stand for analogue output 1 and analogue output 2
Do1 and Do2 stand for switching Output 1 and Switching Output 2
Ain stands for analogue Input

9.1.3 General Functions (configuration layer: c 0 ! !)

Parameter	Function	Explanation
LEd6	Green status LED	<ul style="list-style-type: none"> o n LED indicates 24V d o 1 LED indicates digital output 1 d o 2 LED indicates digital output 2 t R c 1 LED indicates running measurement in mode for ADT function
P .L o.	Activate laser*	<ul style="list-style-type: none"> o n keypress o F F laser disabled t d . 1 edge-triggered, switching input 1 t d . 2 edge-triggered, switching input 2
P .L t	Laser ON-time	1 - 15: select auto laser shut off in minutes
t E r n.	Assign Interface	<ul style="list-style-type: none"> o F F non-terminal mode U S B terminal mode at USB interface r S 485 Terminal mode at RS485 (Half duplex)
A S t r.	Automatic temperature data output	<ul style="list-style-type: none"> o F F automatic temp. data output is off. o n temp. data output at PC terminal
A c y c.	Cycle for automatic temp. data output	Select cycle time in s
A d d r.	Device address	Enter address of device for non-terminal mode
d . S P.	Display panel**	<ul style="list-style-type: none"> "o n" the display panel indicates "on" .R 1 indicate temperature of source Ao1
U n i t	temperature scale	<ul style="list-style-type: none"> o C degrees Celsius o F degrees Fahrenheit
c o u t.	Screen insert temperature reading**	<ul style="list-style-type: none"> o n on o F F off
c t b c.	TBC exposure metering**	<ul style="list-style-type: none"> "o n" spot weighted "o F F" average
c c o L.	White balance**	<ul style="list-style-type: none"> "D A Y L." daylight "A U T o." automatic
c . i d.	Measuring point number**	Number which is shown in the camera image
S A v E	Save	Save changes / exit menu
E S c	Escape	Discard changes / exit menu

* only available for models with laser sighting

** only available for models with camera

9.1.4 Displayed temperature readings

(Configuration layer: **c 020**)

Parameter	Function	Explanation
L1.	Temp. reading Lambda1	Shows current temperature reading for L1
L1Pr.	Reading Lambda1 without peak picker	Shows current temperature reading for L1 prior to peak picker
Int.	Internal temperature	Current internal temp. of device
An	Initial value at analogue input	Current value of analogue input when activated
Esc	Escape	Exit menu

9.1.5 Simulated current signal for outputs Ao1 and Ao2

(configuration layer: **c 100**)

Parameter	Function	Explanation
Ao1.	Current output 1	Enter a value in milliampere to simulate a current signal for Ao1
Ao1t	Current output 1 incl. scaled temperature	Enter a temperature value to simulate a temperature reading for Ao1 (based on linear scale).
Ao2.	Current output 2*	Enter a value in milliampere to simulate a current signal for Ao2
Ao2t	Current output 2 incl. scaled temperature*	Enter a temperature value to simulate a temperature reading for Ao2 (based on linear scale).
Esc	Escape	Exit menu

* Function only available when Current Output 2 is activated.

10 CellaView software

The CellaView software displays, evaluates and stores the temperature readings of your pyrometer.

Download the CellaView software here:

www.keller.de/its/

11 Installation of the USB driver

The PA pyrometer can be addressed via a special driver. On systems with Windows 7, 8 or 10 the driver installs a virtual COM interface which allows access to the serial port of the pyrometer.

Use the link below to download the driver.

www.prolific.com.tw (PL2303 Prolific Driverinstaller.zip v1.x.x)

Alternatively, the USB driver can be downloaded from our website in the CellaView download area.

Install the driver and connect the pyrometer to the PC (USB cable is included in the scope of delivery). Windows will recognise the new hardware. Windows automatically assigns a virtual COM port. To determine the COM port number assigned to the adapter, check the Device Manager as follows:

First, open the Run dialog box by using the Windows key + R key combination. Then enter the command “devgmt.msc.”

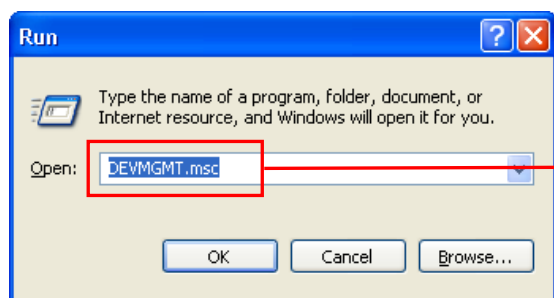

and click OK to open the Device Manager. Then click

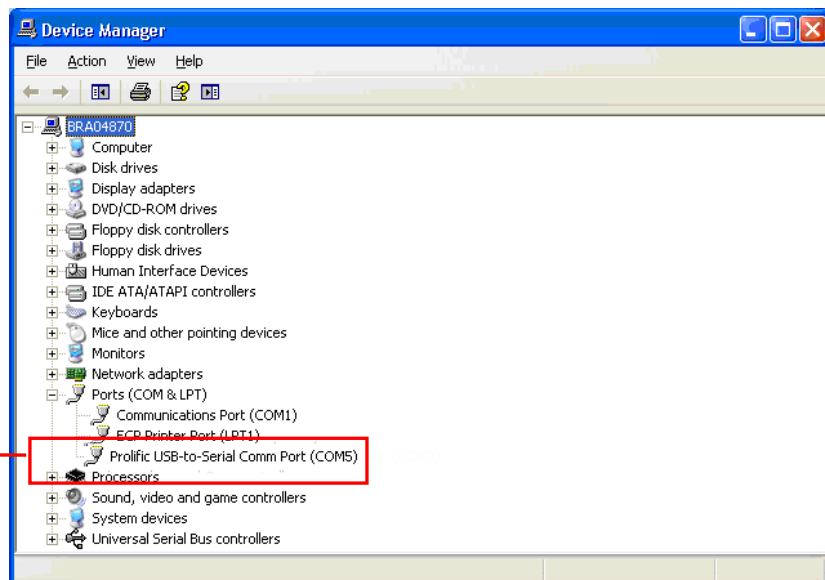

Ports (COM and LPT). You will see a listing of ports and should now be able to see which COM Port the PA USB connection assigned to. The PA USB connection will be indicated as a USB-to-Serial Comm Port. In this example, COM Port 5 has been assigned to the adapter. You will need to select this COM Port in the software settings.

12 How to operate the pyrometer with the CellaView software

It is not necessary to change settings when using the CellaView software. The CellaView software both works via USB and RS485 interface. The interface can be operated either as a point-to-point connection to connect a device or as a bus to connect to 31 pyrometers.

12.1 CellaView via USB point-to-point connection

- ▶ Install the USB driver
- ▶ Connect the pyrometer to the PC
- ▶ Start CellaView
- ▶ Select the correct COM port or use the CellaView search function.

For more information on how to work with CellaView read the separate CellaView manual.

12.2 CellaView via RS485 point-to-point connection

A USB/RS485 converter is needed when working with the RS485 interface. The pyrometer can be directly connected if the PC has an integrated RS485 Interface board. The distance between pyrometer and PC can be up to 1200 m.

To prevent reflections on the RS485 connection, it is absolutely necessary to terminate the connection at the pyrometer and at the converter. The termination is integrated in the PA pyrometer and is active when delivered from the factory.

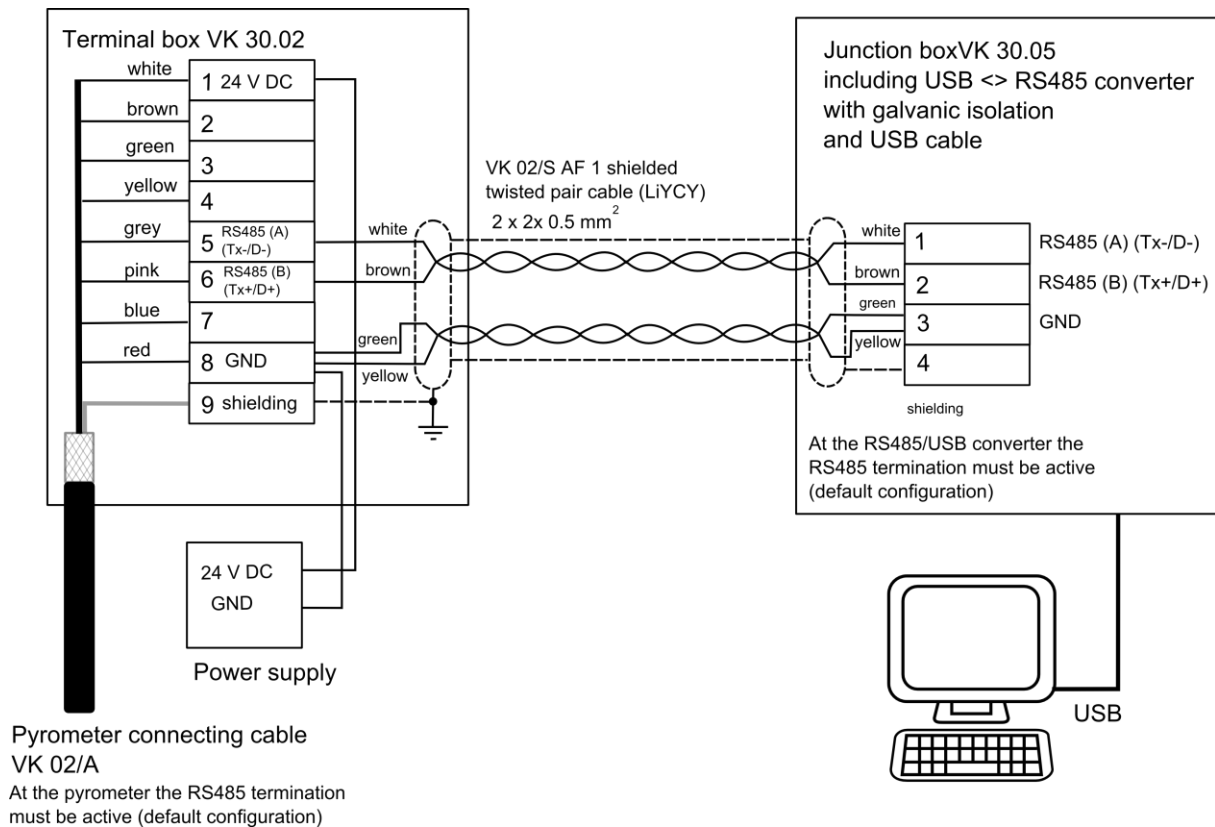

Moreover, use a converter with galvanic isolation (e.g. W&T 38211) to avoid problems with ground loops.

⚠ Attention

If the supply voltage or current output are conducted via this cable, then make sure to consider the voltage drop if the cable length is greater than 100 m.

- ▶ Disconnect the pyrometer from any voltage source
- ▶ Install all required electric connections
- ▶ Connect the converter with the PC
- ▶ Install the converter according to instructions
- ▶ Connect the voltage supply for the pyrometer
- ▶ Start CellaView
- ▶ Select the correct COM port or use the CellaView search function.

For more information on how to work with CellaView read the separate CellaView manual.

12.3 CellaView via RS485 bus connection

The RS485 two-wire bus consists of the bus cable itself with a maximum length of 1200 m. The participants are connected to this cable via a branch line with a length of 5 m max.

Up to 31 pyrometers can be connected to the RS485 bus. CellaView controls the communication on the bus and prompts allocated pyrometers to send or to receive data. Each participant will be addressed by a unique address. Configure this address during setup of each pyrometer using the keyboard.

Configuration layer: `c 0 ! !`

Addr.	Device address	Enter address of device for protocol mode
-------	----------------	---

A USB/RS485 converter is needed when working with the RS485 interface. The pyrometer can be directly connected if the PC has an integrated RS485 Interface board.

In order to prevent reflections on the RS485 connection, it is absolutely necessary to terminate the bus system with termination network. The termination can be activated or deactivated by a DIP switch on the PA pyrometer. The termination is active when delivered from the factory. Moreover, use a converter with galvanic isolation (e.g. W&T 38211) to avoid problems with ground loops.

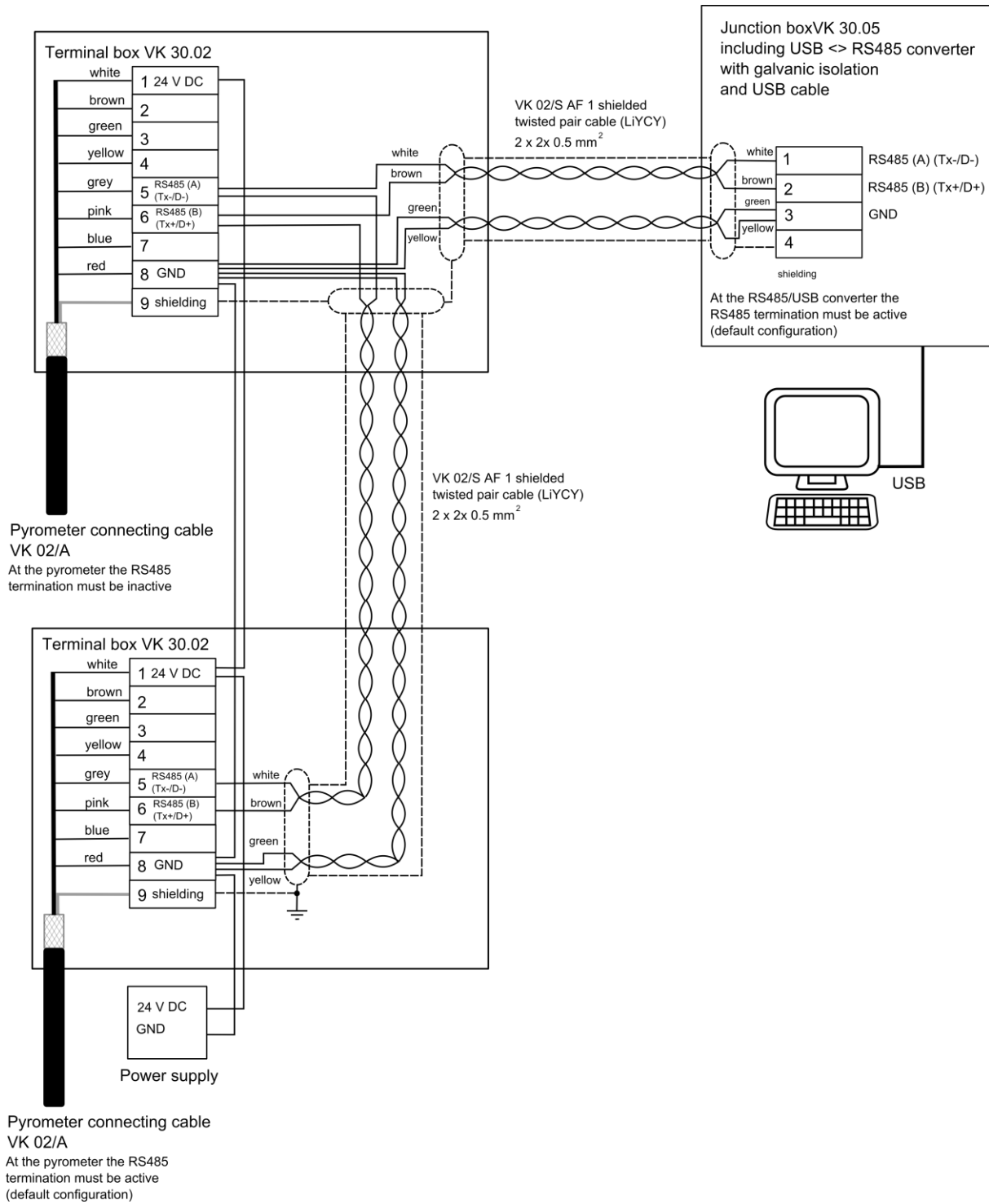

⚠ Attention
All pyrometers must be connected to the same voltage supply. The maximum length of the branch lines to the pyrometer is 5 m

- ▶ Disconnect the pyrometer from any voltage source
- ▶ Activate or deactivate the termination of the respective participant (see termination of RS485 bus)
- ▶ Install all required electric connections
- ▶ Connect the converter with the PC
- ▶ Install the converter according to instructions
- ▶ Connect the voltage supply for the pyrometers
- ▶ Adapt the addresses of the participants
- ▶ Start CellaView
- ▶ Select the correct COM port or use the CellaView search function.

12.4 Termination of RS485 bus

The terminal resistor of the pyrometer must be activated on the relevant bus end. For this purpose, set the DIP switches to ON. Deactivate the termination with the remaining pyrometers.

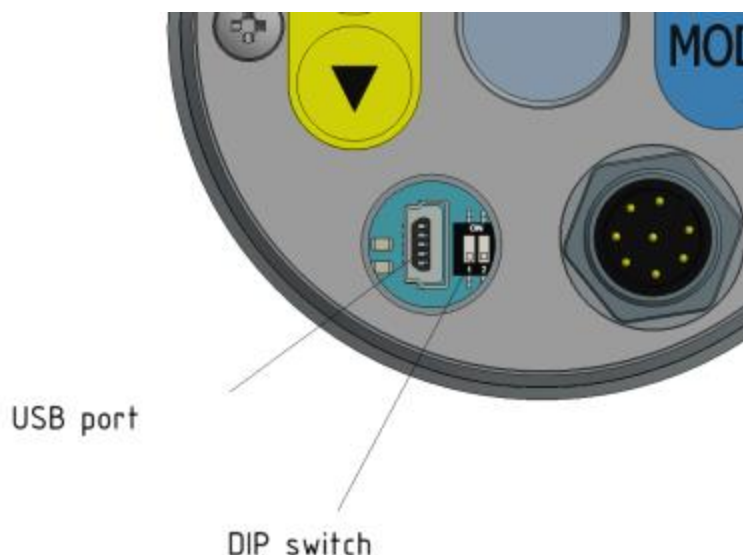

13 Operation of the pyrometer via terminal program

By default, the pyrometer has fully integrated communications software to the point-to-point connection with a PC. As an alternative to the CellaView software, all parameters that are required for a measurement data acquisition or a general configuration of the pyrometer can be configured via a simple terminal connection using the terminal program.

Most key parameters are directly available in the main menu. Further functions are contained in submenus. Navigation within the menus is explained in the following graphics:

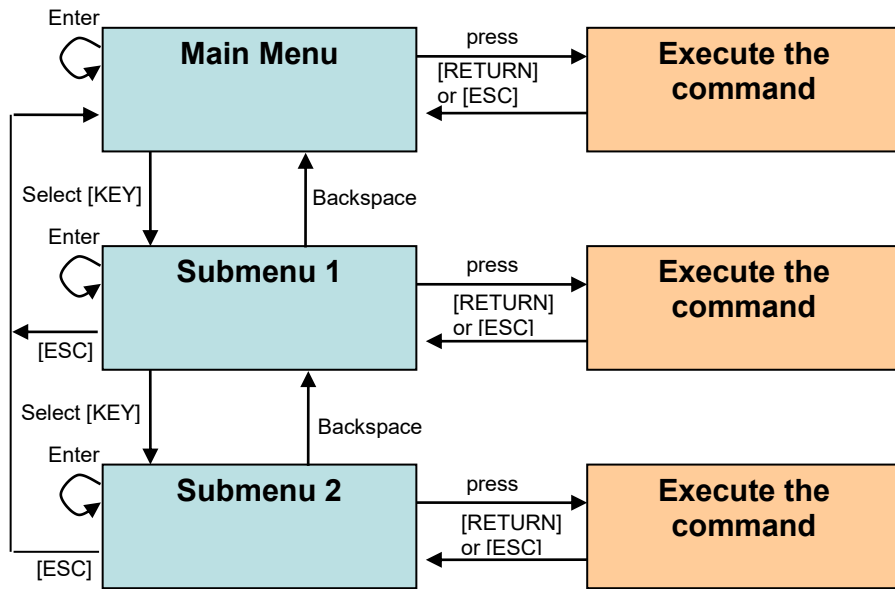

To set the pyrometer to the terminal mode, simultaneously hold down the **Ctrl key** and press the **E key** twice in rapid succession.

Direct commands have an assigned key. Example: E for emissivity (epsilon). Submenu settings are shown in brackets. Example: [LAMBDA 1]

13.1 Serial Data Transmission of Temperature Data

Transmission parameters for the serial interface:

57600 Baud / 8 data bits / odd parity / 1 stop bit / no handshake

Temperature format (one cycle):

Byte	Negative Temperature	Positive Temperature	Temperature falls below measuring range	Temperature exceeds measuring range
1	Minus symbol "-"	Space	Space	Space
2	Digit 1000	Digit 1000	Minus symbol "-"	Minus symbol "-"
3	Digit 100	Digit 100	"U"	"O"
4	Digit 10	Digit 10	"N"	"V"
5	Digit 1	Digit 1	"D"	"E"
6	Decimal point "."	Decimal point "."	"E"	"R"
7	Decimal place	Decimal place	"R"	Space
8	Space	Space	Space	Space
9	Unit "C" or "F"	Unit "C" or "F"	Minus symbol "-"	Minus symbol "-"
10	Space	Space	Space	Space
11	Carriage Return	Carriage Return	Carriage Return	Carriage Return



All symbols are ASCII coded; preceding zeros will be included in the transmission

The cycle time in which the temperature reading is transmitted can be set at the PC terminal (minimum cycle duration is 0.1 second).

13.2 Terminal connection via USB

For communication through a terminal connection via USB set the parameter E r n on the pyrometer to USB (default setting).

The parameter E r n is available on configuration layer C011.

Parameter $\text{E r n} = \text{USB}$

- ▶ Install the pyrometer's USB driver on the PC
- ▶ Connect the pyrometer with a USB cable to the PC
- ▶ Start a standard terminal program (e.g. Windows HyperTerminal or Putty)
- ▶ Select the correct COM port
- ▶ Set the interface parameters for the serial interface (see chapter transmission of measurement values)
- ▶ Open the connection

13.3 Terminal connection via RS485

For communication through a terminal connection via RS485 set the parameter E r n on the pyrometer to r 485 .

The parameter E r n is available on configuration layer C011.

Parameter $\text{E r n} = \text{r 485}$

Attention

When using a terminal connection via the RS485 interface, CellaView cannot be used via the RS485 interface any longer.

A USB/RS485 converter is needed when working with the RS485 interface. The distance between pyrometer and PC can be up to 1200 m.

To prevent reflections on the RS485 connection, it is absolutely necessary to terminate the connection at the pyrometer and at the converter. The termination is integrated in the PA pyrometer and is active when delivered from the factory.

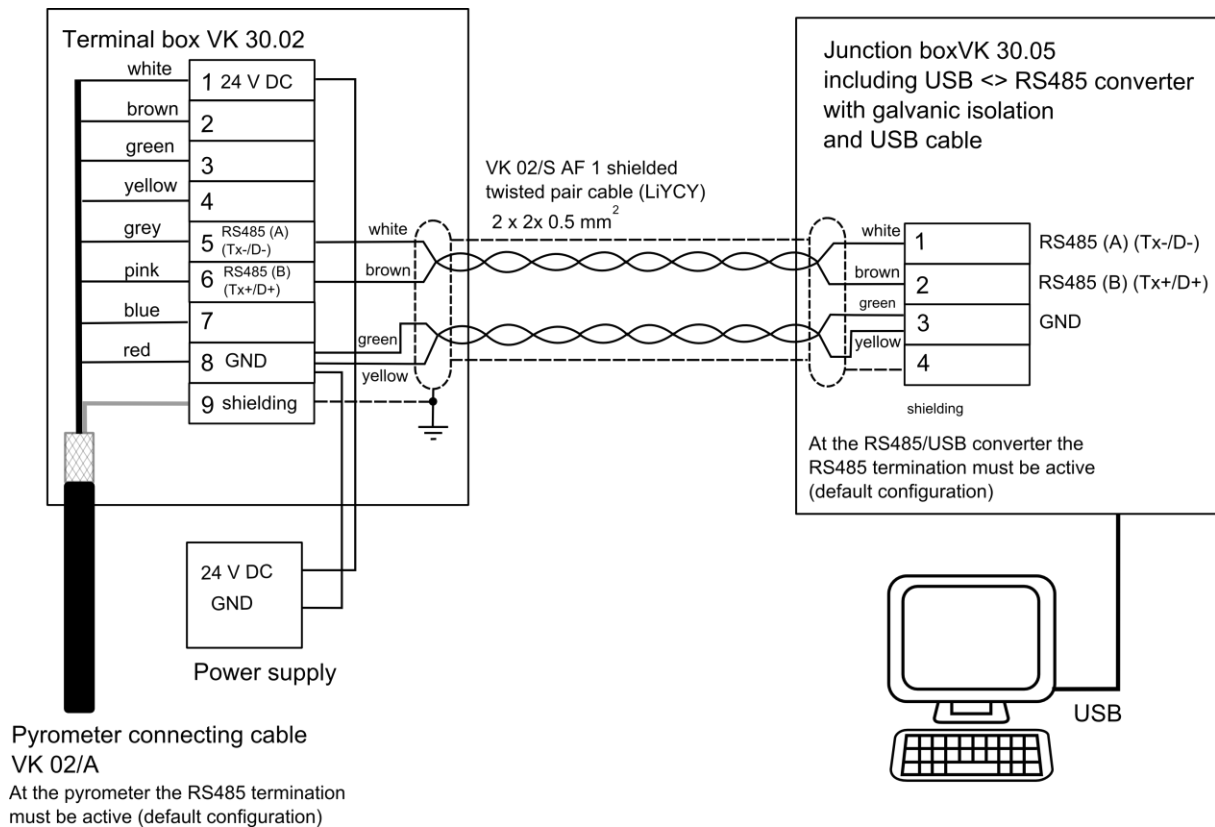

Moreover, use a converter with galvanic isolation (e.g. W&T 38211) to avoid problems with ground loops.

⚠ Attention

If the supply voltage or current output are conducted via this cable, then make sure to consider the voltage drop if the cable length is greater than 100 m.

- ▶ Disconnect the pyrometer from any voltage source
- ▶ Install all required electric connections
- ▶ Connect the converter with the PC
- ▶ Install the converter according to instructions.
- ▶ Connect the voltage supply for the pyrometer
- ▶ Change the parameter `TERN` to `r485`
- ▶ Start a terminal program such as HyperTerminal
- ▶ Select the correct COM port
- ▶ Set the correct parameters for the serial interface (see chapter transmission of measurement values)
- ▶ Open the connection

14 User calibration / scaling of the current output

If necessary, the pyrometer can be adjusted with a user-defined calibration function. The following drawing explains the effects for offset and factor.

T_{shall}

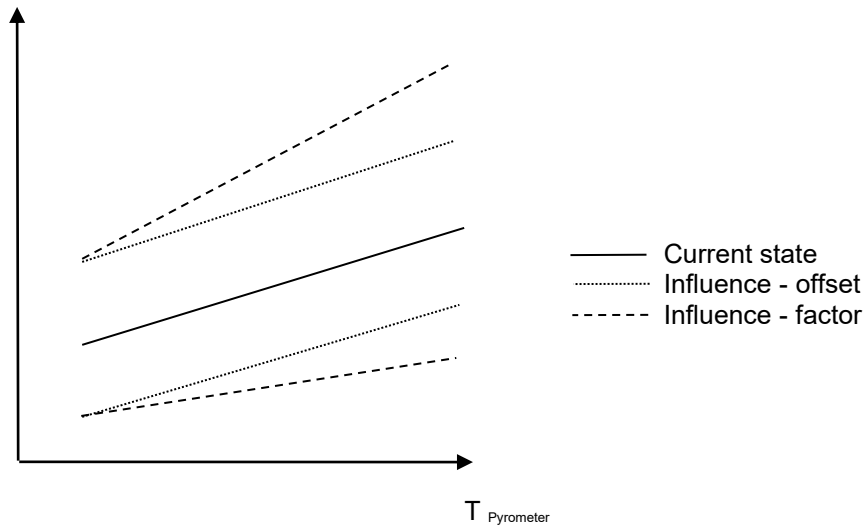

! Attention

To recalibrate your CellaTemp PA, you will require a calibration furnace and a reference standard

In addition to a user-defined calibration, the user-defined range function can also be activated. With this function being active, scaling of the current output can be extended.



The measuring accuracy is not defined when the scaling is outside the pyrometer range.

14.1 Calibration/scaling via CellaView

To use the user-defined calibration function, activate it first in expert mode.

- ▶ Start CellaView
- ▶ Open the menu Settings Extras -> Settings
- ▶ Select expert mode and activate editable calibration
- ▶ Close the menu
- ▶ Open the menu Pyrometer settings

The parameters can now be edited under the tab Spectral channel 1.

14.2 Calibration/scaling via terminal connection

If ever required, the CellaTemp PA can be recalibrated using the sub-menu Calibration. Press command „K“ and then enter the password „100“ to access the calibration menu.

The calibration menu opens.

```

-----
-----
Submenu CALIBRATION
-----
Name .... "Pyrometer PA Series"

1: [LAMBDA 1 CALIBRATION]
A: Reset settings to factory default
S: Set pyrometer name
Z: End Calibration-Mode
ESC: Back to MAIN-MENU
-----
>CALIBRATION >

-----
-----
Submenu LAMBDA 1
-----
L1 range ....      0.0 - 1000.0 C
L1 User calibration ..... off
L1 User def. offset   +0.00000
L1 User def. factor   +1.00000

A: Set L1 - extended-range
B: Set L1 User-Cal. On/Off
C: Set L1 User-Cal. Offset
D: Set L1 User-Cal. Factor
ESC: Back to MAIN-MENU
-----
>CALIBRATION >LAMBDA 1 >

```

You can reset all configurations you have made to your CellaTemp PA and restore the factory default settings using Command „A“. This also applies to data acquisition parameters and input/output settings. Use keys "B", "C" and "D" for direct access to enable the adjustments.

If you make a mistake while making the adjustments, simply enter offset = 0.0 und factor = 1.0, or set User Cal. to „off“.

Command "A" redefines the pyrometer's entire measuring range. This new temperature span may be smaller or larger than the range originally programmed by the manufacturer. When selecting a new temperature range for your CellaTemp PA, make sure that the temperature span you select is actually covered by the pyrometer model you have purchased. The only way to be certain is to perform measurement tests.

Press "S" to enter a short text to name the control point. View this text by selecting „Q“ in the Main Menu.

15 Shielding and Grounding

15.1.1 Potential equalisation

⚠ Attention

All applicable laws and codes must be complied with at all times

The pyrometer housing is connected to the shielding via the cable connector! Differences in ground potentials might cause an equalising current to flow between devices through a cable shielded at both ends.

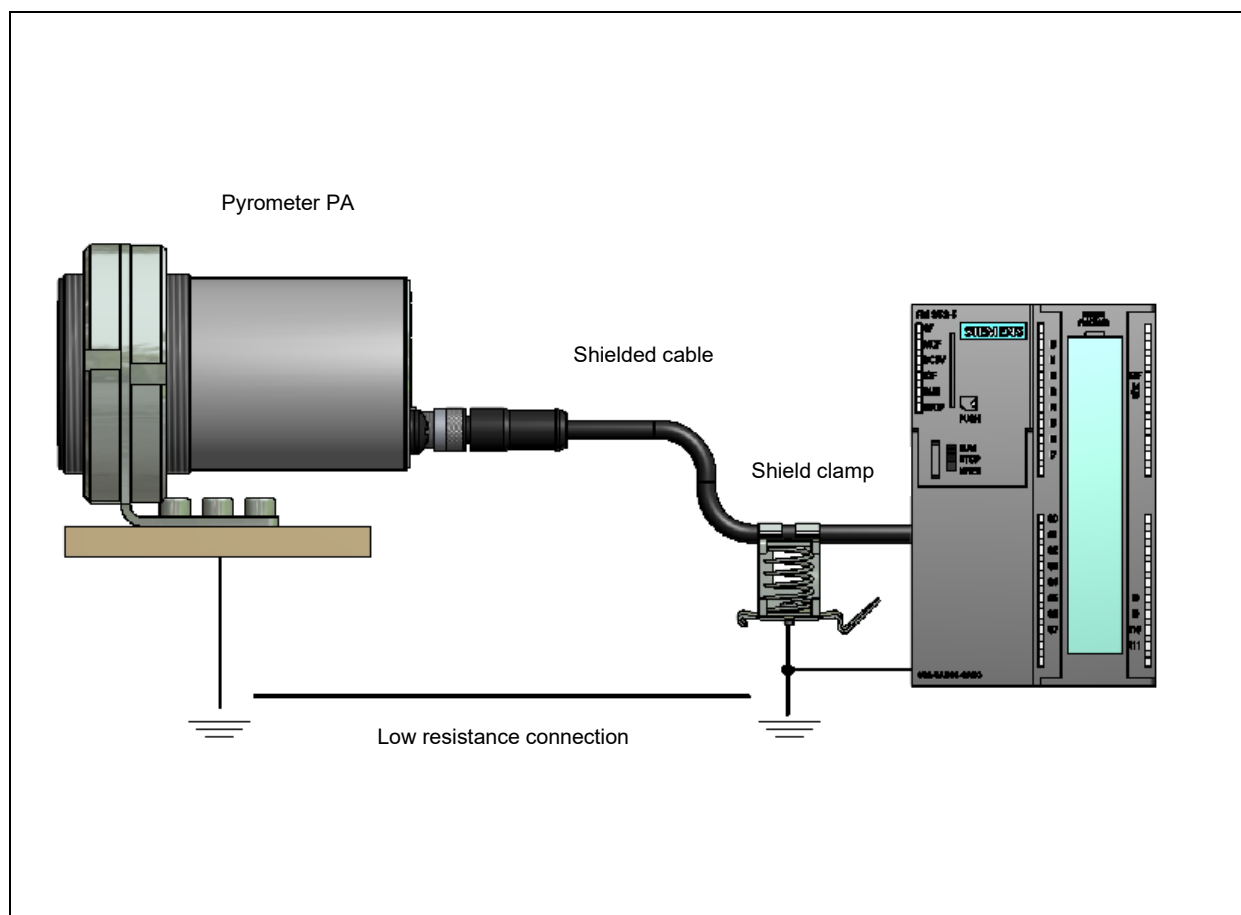

In this case, be sure to install an additional potential equalisation line.

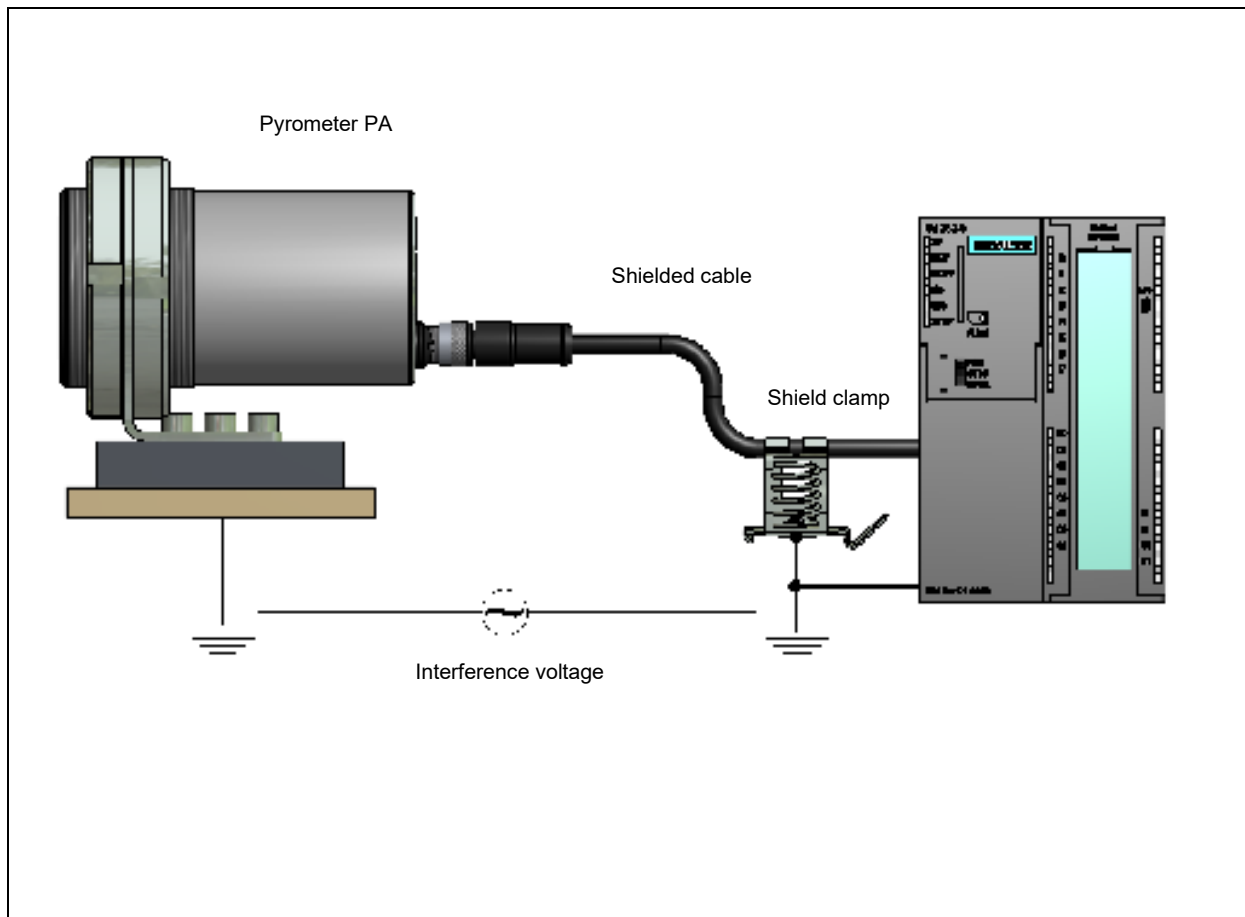

To avoid an equalising current, the pyrometer can be mounted electrically insulated. The shielding must be connected to the plant's earthing system.

⚠ Attention

If the pyrometer is installed without an insulator and without potential equalisation, the interference voltage may not exceed 48V.

16 Connectivity Examples

16.1 Connection to VK 02/A Cable

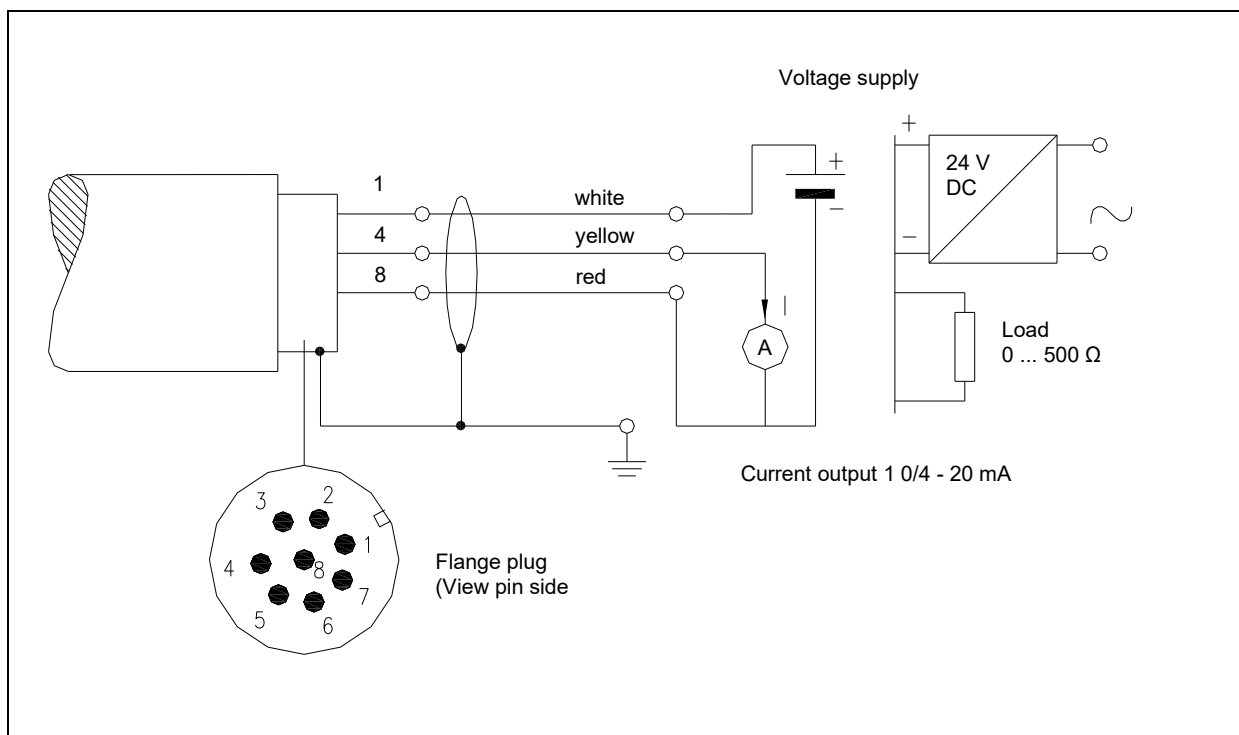

16.2 Connection to DA 230 digital display unit

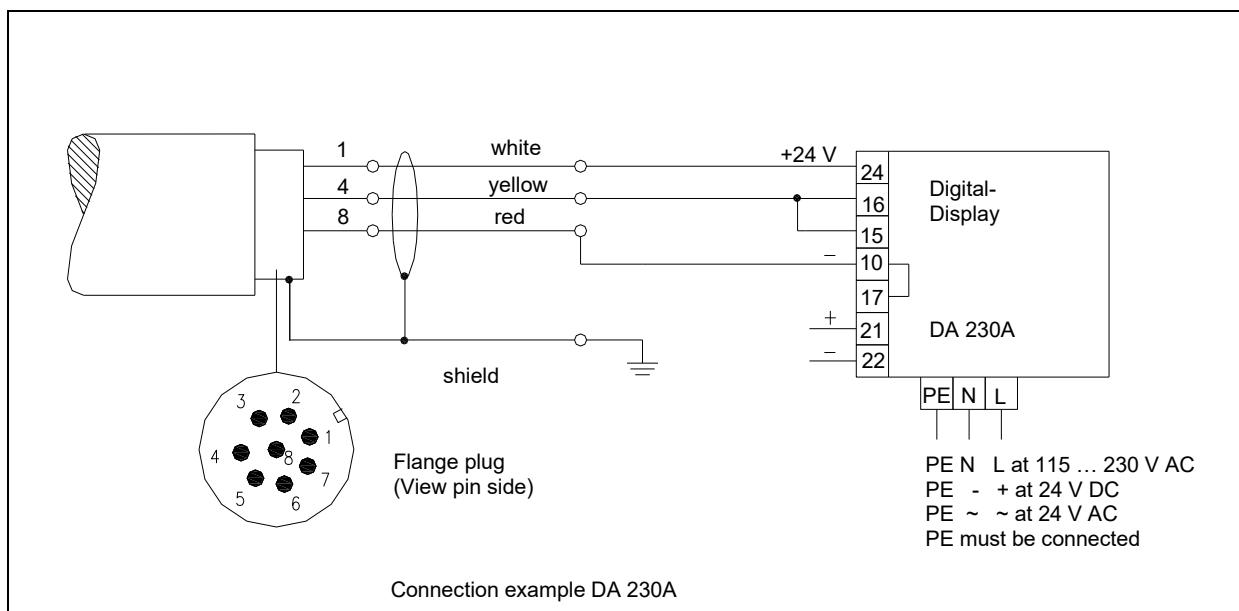

17 Theory of Non-Contact Temperature Measurements

All materials radiate thermal energy in all states of aggregation above absolute zero. This radiation is mainly caused by atomic or molecular oscillations. This temperature radiation is only a limited sector within the total electromagnetic radiation spectrum. It extends from the visible range starting at wavelengths of approx. 0.5 μm to the infrared range with wavelengths of more than 40 μm . The KELLER HCW PA radiation pyrometers detect infrared radiation for non-contact temperature measurement.

17.1 Advantages of Non-Contact Temperature Measurement

Non-contact temperature detection means cost-effective temperature measurement because this technique only requires a single investment in an instrument without any follow-up costs for consumables such as thermocouples. This method enables temperature detection of moving objects - quick temperature measurements within milliseconds - for example at automatic welding processes. Small objects with medium and high temperatures can also be easily and accurately measured. When measuring materials with low specific heat, a non-contact method does not induce heat loss which would distort the temperature reading (as is the case with contact temperature probes). Non-contact temperature detection is ideal with corrosive molten materials for which the use of thermocouples is hardly feasible. Last but not least it is also possible to measure the temperature of voltage-carrying objects.

17.2 Measurements at Black Bodies (Cavity Radiators)

A black body or a black radiator is used to calibrate radiation pyrometers. This black body is designed in a way that its radiation does not depend on material characteristics, but only on its temperature. A black body emits at any wavelength the maximum energy possible for the specific temperature. Real bodies do not have this ability. In other words, a black body completely absorbs the radiation without reflection or transmission losses. The spectral emissivity coefficient $\varepsilon(\lambda)$ of a black body is equal to 1 or 100 %. The emissivity coefficient indicates the ratio of radiation of a real body (target) to the radiation of an ideal black body.

$$\varepsilon(\lambda) = \frac{M}{M_S}$$

$\varepsilon(\lambda)$: Emissivity coefficient of the object's surface (targeted spot) at wavelength λ

M : radiant energy emitted by a real object

M_S : radiant energy emitted by a black body (perfect radiator)

Most burning, annealing and hardening furnaces emit a radiation of nearly '1' which corresponds to the conditions of a black body if the aperture through which the measurement is made is relatively small.

17.3 Measurements of Real Radiators

Real radiation sources are characterized by the relation of the emitted radiation to the radiation of a black body with the same temperature. Measurements outside a furnace - which applies to all other self-contained targets - always show a reading which is too low. Considerable errors can occur at targets with reflecting, polished or bright surfaces, e.g. molten steel and metal without oxide layer and ceramic materials. Exact results can only be obtained when the emissivity coefficient is correctly adjusted on the PA pyrometer.

The spectral emissivity coefficient of a body does not represent an exact material constant but is also largely dependent on the surface properties. For different materials the spectral emissivity coefficient ε for the spectral ranges $\lambda = 8 - 14 \mu\text{m}$ (PA 10), $\lambda = 1.1 - 1.7 \mu\text{m}$ (PA 20) and $\lambda = 0.8 - 1.1 \mu\text{m}$ (PA 30) is shown in the following tables:

17.4 Emissivity Coefficient Table PA 10

List of emissivity coefficients of different materials in %

CellaTemp	PA 10
Wavelength λ	8 - 14 μm
"Black body"	100
Aluminium oxide	76
Asphalt	90 - 98
Baking oven, dark colour	96
Concrete	55 - 65
Bitumen (roofing paper)	96
Bread in baking oven	88
Ferrous oxide	85 - 89
Enamel	84 - 88
Earth	92 - 96
Paint and varnish, bright	92
Paint and varnish, pale	96
Gypsum	80 - 90
Glass	85 - 95
Graphite	98
Rubber, black	94
Skin, human	98
Wood	80 - 90
Radiator	80 - 85
Lime cast	91
Clinker bricks, glazed	75
Cooking plate	95
Synthetic material, nontrans parent	65 - 95
Copper, oxidized	78
Leather	75 - 80
Marble	94
Brass, oxidized	56 - 64
Paper	70 - 94
Sand	90
Fireclay	75
Steel, stainless	45
Steel, rusty	69
Textiles	75 - 88
Water	92 - 98
Cement	90
Bricks	93 - 96

17.5 Emissivity Coefficient Table PA 20 – PA 30

List of emissivity coefficients of different materials in %

CellaTemp	PA 20	PA 30
Wavelength λ	1.1 – 1.7 μm	0.8 – 1.1 μm
"Black Body"	100	100
Aluminium, polished	5	15
Aluminium, blackened	10	25
Asbestos cement	60	70
Bronze, polished	1	3
Bronze, blackened	15	30
Chromium, polished	15	30
Iron, heavily scaled	90	95
Iron, rolling skin	75	90
Iron, liquid	15	30
Gold and silver	1	2
Graphite, blackened	85	90
Copper, oxidized	70	90
Brass, oxidized (tarnished)	50	70
Nickel	8	20
Porcelain, glazed	50	60
Porcelain, rough	75	85
Soot	90	95
Fireclay	40	50
Slag	80	85
Pottery, glazed	85	90
Bricks	85	90
Zinc	40	60

18 Maintenance

18.1 Cleaning the pyrometer lens

A false temperature reading will be given when the lens is dirty. Therefore, check the lens periodically and clean it, if necessary.

Dust can be removed by simply blowing it away or by using a soft brush. A special lens cleaning cloth is ideal, but any soft, clean, lint-free cloth will be suitable.

If the lens is quite dirty, use a very mild liquid detergent and rinse carefully with clear water while holding the pyrometer down. Apply as little pressure as possible to avoid scratching the lens.

Make sure to turn off the pyrometer prior to connecting or disconnecting the coupler connector (e.g. when cleaning). Failure to do so may result in damage to the instrument!

Attention

Please note that the lens may only be mounted/removed when the pyrometer is switched off. Failure to observe this precaution may result in damage to the device!

Attention

For pyrometers with laser pilot lights, the objective lens may only be cleaned or mounted/dismounted when the pyrometer is switched off. Damage to the retina is possible.



The pyrometer must be protected against high ambient temperatures, high air humidity, high voltage and strong electromagnetic fields. Never hold the lens directly into the sun.

19 Type overview

Type	Measuring range	Application
PA 10	0 – 1000 °C	Non-metals
PA 13	500 – 1300 °C	Flame-heated furnaces
PA 15	300 – 1300 °C 500 – 2500 °C	Glass surfaces
PA 17	500 – 2000 °C	CO ₂ band
PA 18	500 – 2500 °C	Hot combustion gases
PA 20	250 – 2000 °C 350 – 2500 °C	Metal, ceramics, glass melting
PA 28	75 – 650 °C	Aluminium, metallic bare surfaces Laser application
PA 29	150 – 800 °C 180 – 1200 °C 250 – 2000 °C 350 – 2500 °C	Aluminium, metallic bare surfaces Laser application
PA 30	500 – 2500 °C	Metal, ceramics, at high tem- peratures
PA 35	600 – 3000 °C	Precise measurement of met- als, semiconductors

20 Technical Data PA 10

<p>Measuring ranges: (adjustable in partial ranges): 0 - 1000 °C</p> <p>Sensor: thin-film thermopile</p> <p>Spectral sensitivity: 8 - 14 µm</p> <p>Focussing range: 0.15 - 0,3 m (close-up lens) 0.3 m - ∞ (standard lens)</p> <p>Distance to target size ratio: 48 :1 at 300 mm (close-up lens) 50 :1 at 300 mm (standard lens)</p> <p>Digital output: Periodic output of measurement data with adjustable cycle time</p> <p>Analogue output 1 & 2: 0(4) - 20 mA linear, switchable, scalable (4 - 20 mA normally)</p> <p>Resistance: max. 500 Ω</p> <p>Response time t₉₀: ≤ 30 ms</p> <p>Resolution Analogue output: 0.2 K + 0.03 % of the adjusted span</p> <p>Resolution Display: 0.1 K < 200 °C 1 K ≥ 200 °C</p> <p>Resolution USB / RS 485: 0.1 K at terminal operation</p> <p>Measuring uncertainty: 1 % of reading, min 2 K (if smoothing is = 30 ms) (at ε = 1.0 and TA = 23 °C)</p>	<p>Repeatability: 1 K</p> <p>Sighting device: through-the-lens sighting with target marking, laser spotlight or integrated camera</p> <p>Ambient operating temperature: 0 - 65 °C</p> <p>Indication of Overheating: If the internal temperature of the pyrometer exceeds 80 °C the analogue output will show a value > 20.5 mA</p> <p>Storage temperature: -20 - 80 °C</p> <p>Permissible humidity: 95% r.H. max. (non-condensing)</p> <p>Temperature coefficient with reference to 23 °C: ≤ 0.1 K / K (at T < 250 °C) ≤ 0.04 %/K (at T ≥ 250 °C) of measured value</p> <p>Interface: USB / RS485 with integrated software to set parameters and transmit measurement data to a PC</p> <p>Analogue input: 0 - 10 V</p> <p>Digital output: 2 Open collector outputs 24 V; ≤ 30 mA</p> <p>Digital input: 2 to 24 V</p> <p>Power supply requirements: 24 V DC +10% / -20% current input ≤ 135 mA / ≤ 175 mA with camera, 250 mA with switched on spotlight Ripple: ≤ 200 mV</p> <p>Dimensions: Ø 65 x 220 mm (with connector attached)</p>	<p>Housing material: Stainless steel</p> <p>Mounting: External thread M 65 x 2 length 40 mm</p> <p>Weight: Approx. 0.9 kg</p> <p>Connection: with 8-pin connector</p> <p>Protection: IP 65 according to DIN 40050 (with connector attached)</p> <p>Adjustable parameters:</p> <p>Analogue output 1 & 2: source/ scaling</p> <p>Digital input output 1 & 2: source/ switch point</p> <p>Transmission factor</p> <p>Compensation of background radiation</p> <p>Look-up table for temperature alignment</p> <p>Emissivity ε: 10 - 110 % increment size 0.1 %</p> <p>Smoothing function t₉₈: 0 - 999 sec self-adaptive</p> <p>Memory modes: - Min./Max. (peak picker) - Double maximum with adjustable hold time</p> <p>Optional accessories: calibration certificate according to ISO 9001 calibration certificate according to DKD large variety of mounting devices, digital displays, software, etc.</p>
--	--	---

20.1 Field of View Diagrams for PA 10

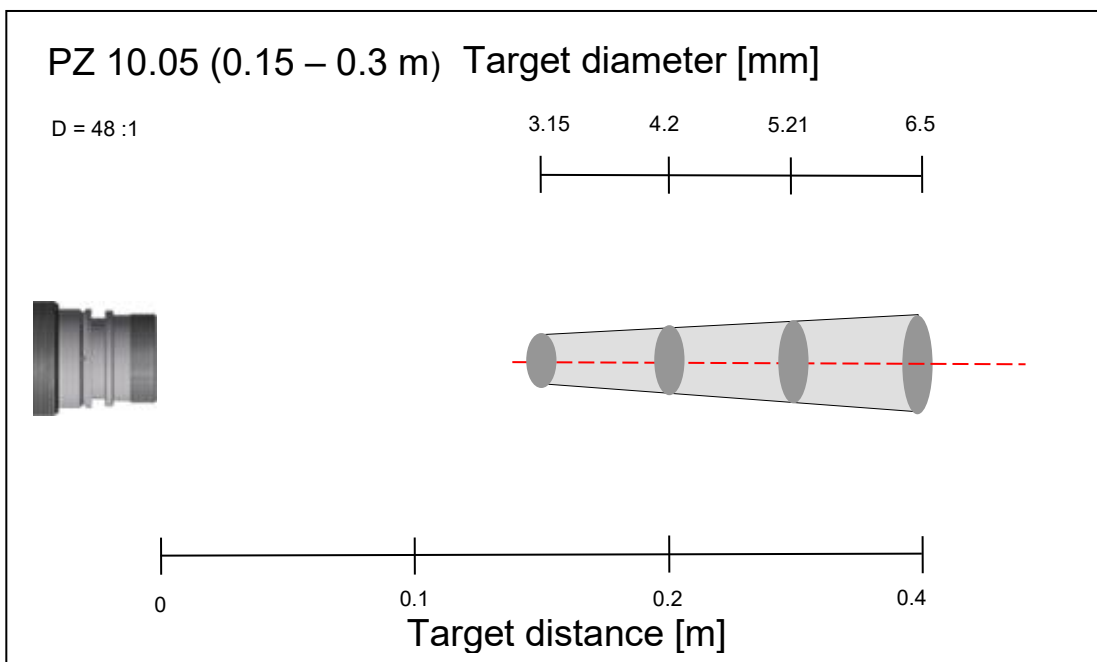
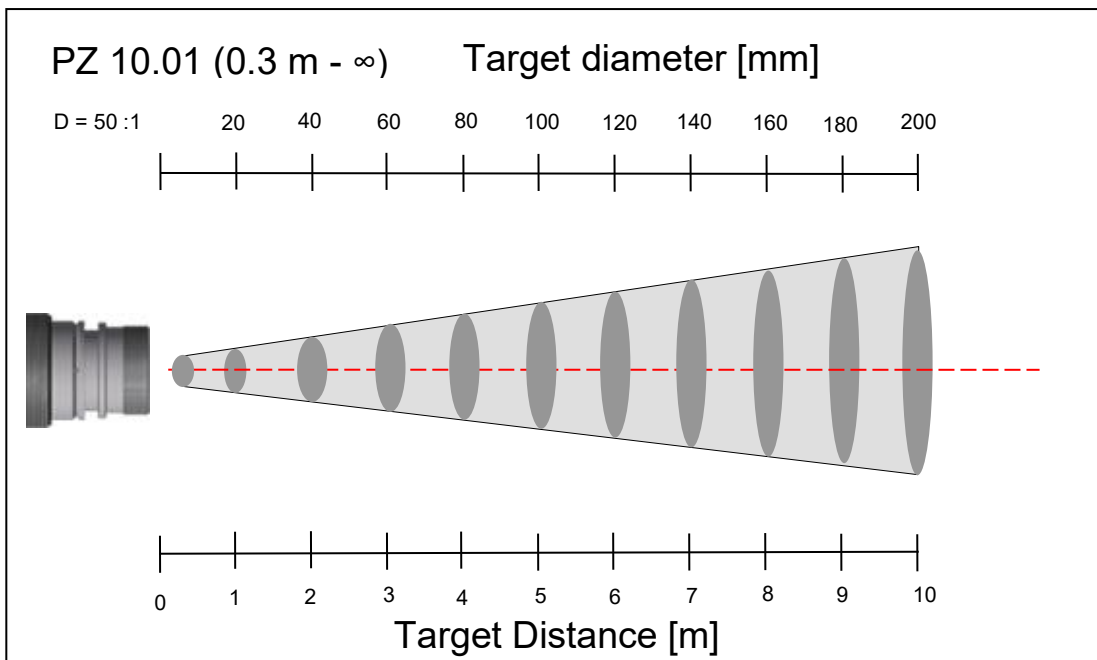

21 Technical Data PA 13

<p>Measuring ranges: (adjustable in partial ranges): 500 - 1600 °C</p>	<p>Sighting device: through-the-lens sighting with target marking, laser spotlight or integrated camera</p>	<p>Mounting: External thread M 65 x 2 length 40 mm</p>
<p>Sensor: Thermopile</p>	<p>Ambient operating temperature: 0 - 65 °C</p>	<p>Weight: Approx. 0.9 kg</p>
<p>Spectral sensitivity: 3.9 µm</p>	<p>Indication of Overheating: If the internal temperature of the pyrometer exceeds 80 °C the analogue output will show a value > 20.5 mA</p>	<p>Connection: with 8-pin connector</p>
<p>Focussing range: 0.8 m - ∞ (standard lens)</p>	<p>Storage temperature: -20 - 80 °C</p>	<p>Protection: IP 65 according to DIN 40050 (with connector attached)</p>
<p>Distance to target size ratio: 45:1 at 800 mm (standard lens)</p>	<p>Permissible humidity: 95% r.H. max. (non-condensing)</p>	<p>Adjustable parameters: Analogue output 1 & 2: source/ scaling</p>
<p>Digital output: Periodic output of measurement data with adjustable cycle time</p>	<p>Temperature coefficient with reference to 23 °C: ≤ 0.04 %/K</p>	<p>Digital input output 1 & 2: source/ switch point</p>
<p>Analogue output 1 & 2: 0(4) - 20 mA linear, switchable, scalable (4 - 20 mA normally)</p>	<p>Interface: USB / RS485 with integrated software to set parameters and transmit measurement data to a PC</p>	<p>Transmission factor</p>
<p>Resistance: max. 500 Ω</p>	<p>Analogue input: 0 - 10 V</p>	<p>Compensation of background radiation</p>
<p>Response time t₉₀: ≤ 100 ms</p>	<p>Digital output: 2 Open collector outputs 24 V; ≤ 30 mA</p>	<p>Look-up table for temperature alignment</p>
<p>Resolution Analogue output: 0.2 K + 0.03 % of the adjusted span</p>	<p>Digital input: 2 to 24 V</p>	<p>Emissivity ε: 10 - 110 % increment size 0.1 %</p>
<p>Resolution Display: 1 K</p>	<p>Power supply requirements: 24 V DC +10% / -20% current input ≤135 mA / ≤175 mA with camera, 150 mA with switched on spotlight Ripple: ≤ 200 mV</p>	<p>Smoothing function t₉₈: 0 – 999 sec</p>
<p>Resolution USB / RS 485: 0.1 K at terminal operation</p>	<p>Dimensions: Ø 65 x 220 mm (with connector attached)</p>	<p>Memory modes: - Min./Max. (peak picker) - Double maximum with adjustable hold time</p>
<p>Measuring uncertainty: 1 % of reading (at ε =1.0 and TA=23 °C)</p>	<p>Housing material: Stainless steel</p>	<p>Optional accessories: calibration certificate according to ISO 9001 calibration certificate according to DKD</p>
<p>Linearisation: digital via microcontroller</p>		<p>large variety of mounting devices, digital displays, software, etc.</p>
<p>Repeatability: 1 K</p>		

21.1 Field of View Diagram for PA 13

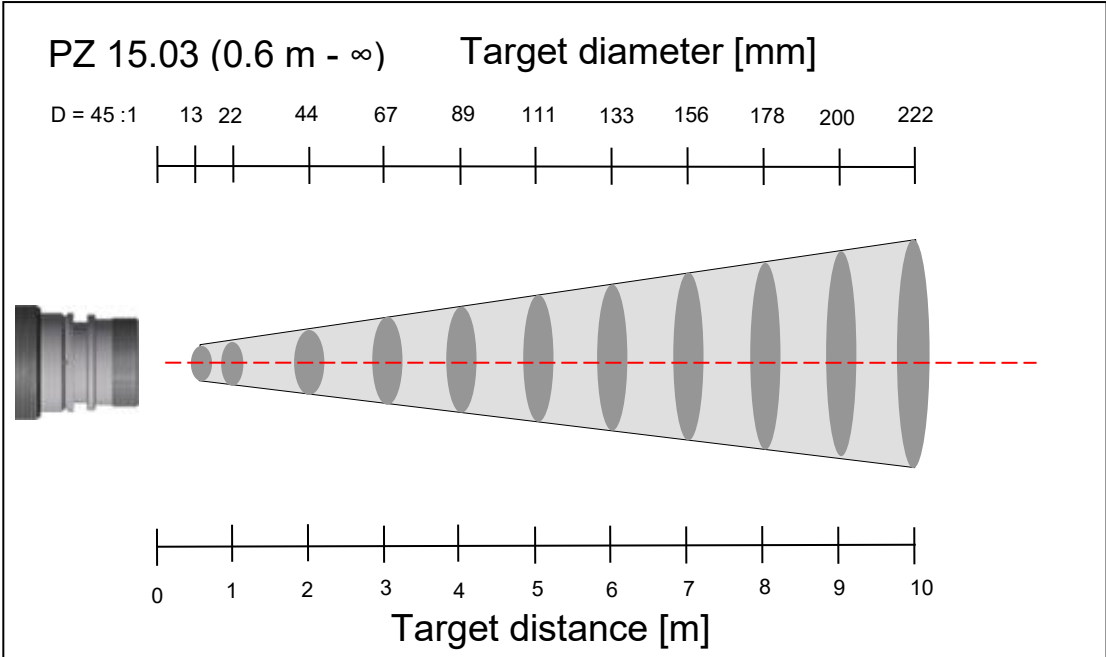

22 Technical Data PA 15

<p>Measuring ranges: (adjustable in partial ranges): MR I: 500 - 2500 °C MR II: 300 - 1300 °C</p> <p>Sensor: Thermopile</p> <p>Spectral sensitivity: 4.6 – 4.9 µm</p> <p>Focussing range: 0.8 m - ∞</p> <p>Distance to target size ratio: MR I: 70:1 at 800 mm MR II: 45:1 at 800 mm</p> <p>Digital output: Periodic output of measurement data with adjustable cycle time</p> <p>Analogue output 1 & 2: 0(4) - 20 mA linear, switchable, scalable (4 - 20 mA normally)</p> <p>Resistance: max. 500 Ω</p> <p>Response time t₉₀: ≤ 100 ms</p> <p>Resolution Analogue output: 0.2 K + 0.03 % of the adjusted span</p> <p>Resolution Display: 1 K</p> <p>Resolution USB / RS 485: 0.1 K at terminal operation</p> <p>Measuring uncertainty: <i>PA 15 AF 1</i> 0.75 % of reading <i>PA 15 AF 2</i> 0.75 % of reading and but at least 3 K (at ε = 1.0 and TA = 23 °C)</p> <p>Linearisation: digital via microcontroller</p>	<p>Repeatability: 1 K</p> <p>Sighting device: through-the-lens sighting with target marking, laser spotlight or integrated camera</p> <p>Ambient operating temperature: 0 - 65 °C</p> <p>Indication of Overheating: If the internal temperature of the pyrometer exceeds 80 °C the analogue output will show a value > 20.5 mA</p> <p>Storage temperature: -20 - 80 °C</p> <p>Permissible humidity: 95% r.H. max. (non-condensing)</p> <p>Temperature coefficient with reference to 23 °C: ≤ 0.04 %/K</p> <p>Interface: USB / RS485 with integrated software to set parameters and transmit measurement data to a PC</p> <p>Analogue input: 0 - 10 V</p> <p>Digital output: 2 Open collector outputs 24 V; ≤ 30 mA</p> <p>Digital input: 2 to 24 V</p> <p>Power supply requirements: 24 V DC +10% / -20% current input ≤ 135 mA / ≤ 175 mA with camera, 150 mA with switched on spotlight Ripple: ≤ 200 mV</p> <p>Dimensions: Ø 65 x 220 mm (with connector attached)</p>	<p>Housing material: Stainless steel</p> <p>Mounting: External thread M 65 x 2 length 40 mm</p> <p>Weight: Approx. 0.9 kg</p> <p>Connection: with 8-pin connector</p> <p>Protection: IP 65 according to DIN 40050 (with connector attached)</p> <p>Adjustable parameters:</p> <p>Analogue output 1 & 2: source/ scaling</p> <p>Digital input output 1 & 2: source/ switch point</p> <p>Transmission factor</p> <p>Compensation of background radiation</p> <p>Look-up table for temperature alignment</p> <p>Emissivity ε: 10 - 110 % increment size 0.1 %</p> <p>Smoothing function t₉₈: 0 – 999 sec</p> <p>Memory modes: - Min./Max. (peak picker) - Double maximum with adjustable hold time</p> <p>Optional accessories: calibration certificate according to ISO 9001 calibration certificate according to DKD large variety of mounting devices, digital displays, software, etc.</p>
--	---	---

22.1 Field of View Diagrams for PA 15

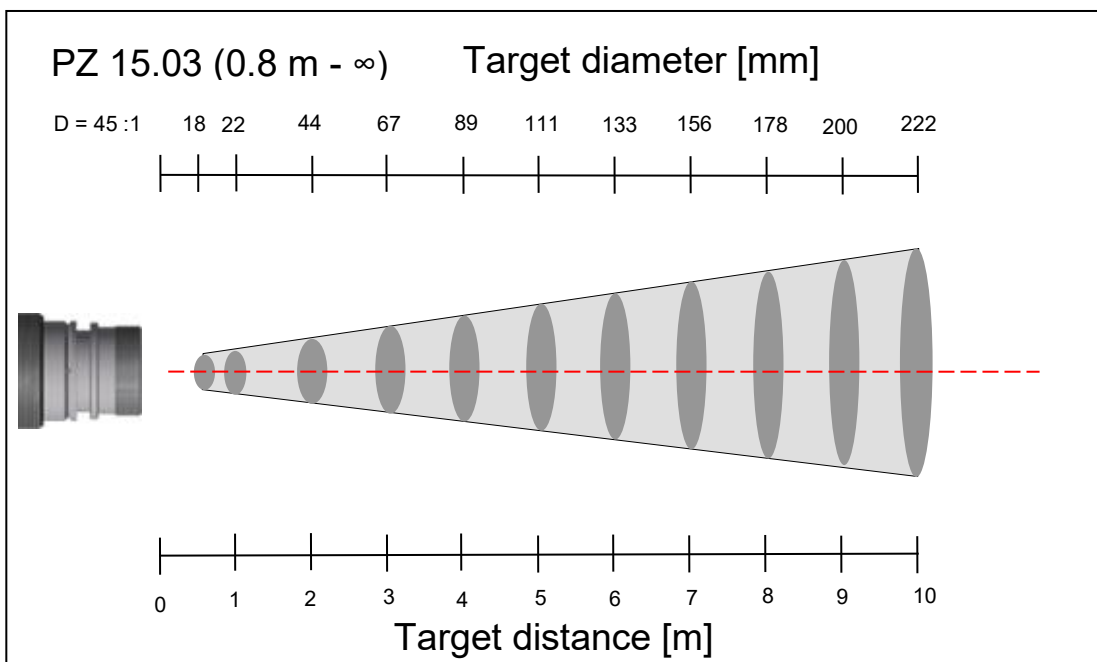
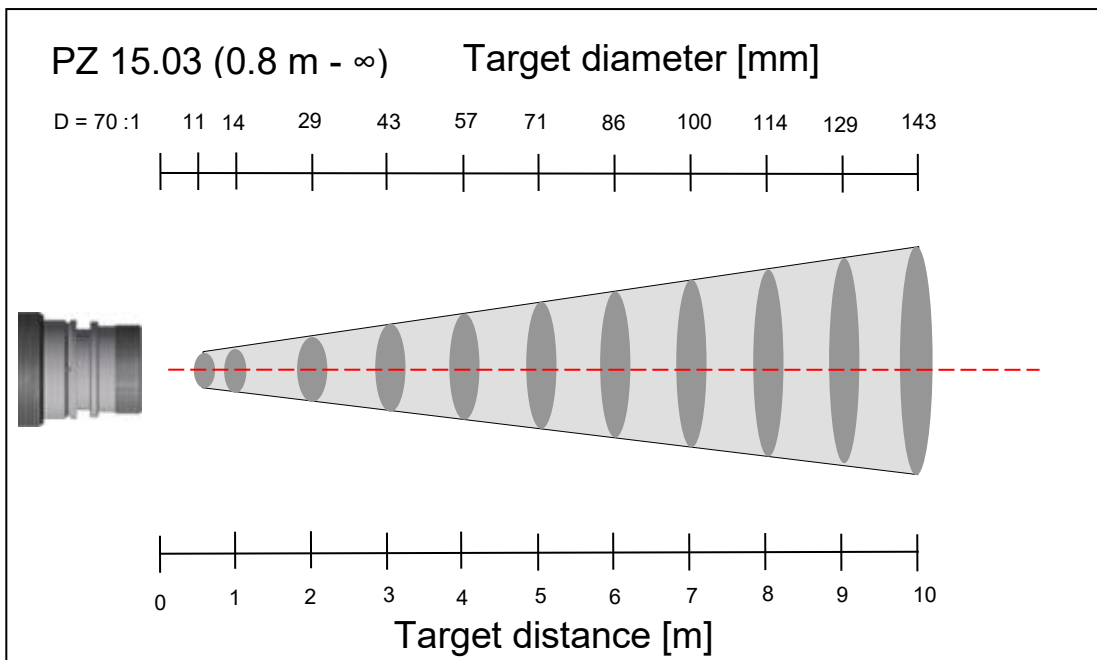

23 Technical Data PA 17

Measuring ranges: (adjustable in partial ranges): 400 - 2000 °C	Ambient operating temperature: 0 - 65 °C	Connection: with 8-pin connector
Sensor: Thermopile	Indication of Overheating: If the internal temperature of the pyrometer exceeds 80 °C the analogue output will show a value > 20.5 mA	Protection: IP 65 according to DIN 40050 (with connector attached)
Spectral sensitivity: CO ₂ band	Storage temperature: -20 - 80 °C	Adjustable parameters:
Focussing range: 0.8 m - ∞	Permissible humidity: 95% r.H. max. (non-condensing)	Analogue output 1 & 2: source/ scaling
Distance to target size ratio: 75:1 at 800 mm	Temperature coefficient with reference to 23 °C: ≤ 0.04 %/K	Digital input output 1 & 2: source/ switch point
Digital output: Periodic output of measurement data with adjustable cycle time	Interface: USB / RS485 with integrated software to set parameters and transmit measurement data to a PC	Transmission factor
Analogue output 1 & 2: 0(4) - 20 mA linear, switchable, scalable (4 - 20 mA normally)	Analogue input: 0 - 10 V	Compensation of background radiation
Resistance: max. 500 Ω	Digital output: 2 Open collector outputs 24 V; ≤ 30 mA	Look-up table for temperature alignment
Response time t₉₀: ≤ 100 ms	Digital input: 2 to 24 V	Emissivity ε: 10 - 110 % increment size 0.1 %
Resolution Analogue output: 0.2 K + 0.03 % of the adjusted span	Power supply requirements: 24 V DC +10% / -20% current input ≤135 mA / ≤175 mA with camera, 150 mA with switched on spotlight Ripple: ≤ 200 mV	Smoothing function t₉₈: 0 – 999 sec
Resolution Display: 1 K	Dimensions: Ø 65 x 220 mm (with connector attached)	Memory modes: - Min./Max. (peak picker) - Double maximum with adjustable hold time
Resolution USB / RS 485: 0.1 K at terminal operation	Housing material: Stainless steel	Optional accessories: calibration certificate according to ISO 9001 calibration certificate according to DKD large variety of mounting devices, digital displays, software, etc.
Measuring uncertainty: 0.75 % of reading + 1 K (at ε =1.0 and TA=23 °C)	Mounting: External thread M 65 x 2 length 40 mm	
Linearisation: digital via microcontroller	Weight: Approx. 0.9 kg	
Repeatability: 2 K		
Sighting device: through-the-lens sighting with target marking, laser spotlight or integrated camera		

23.1 Field of View Diagram for PA 17

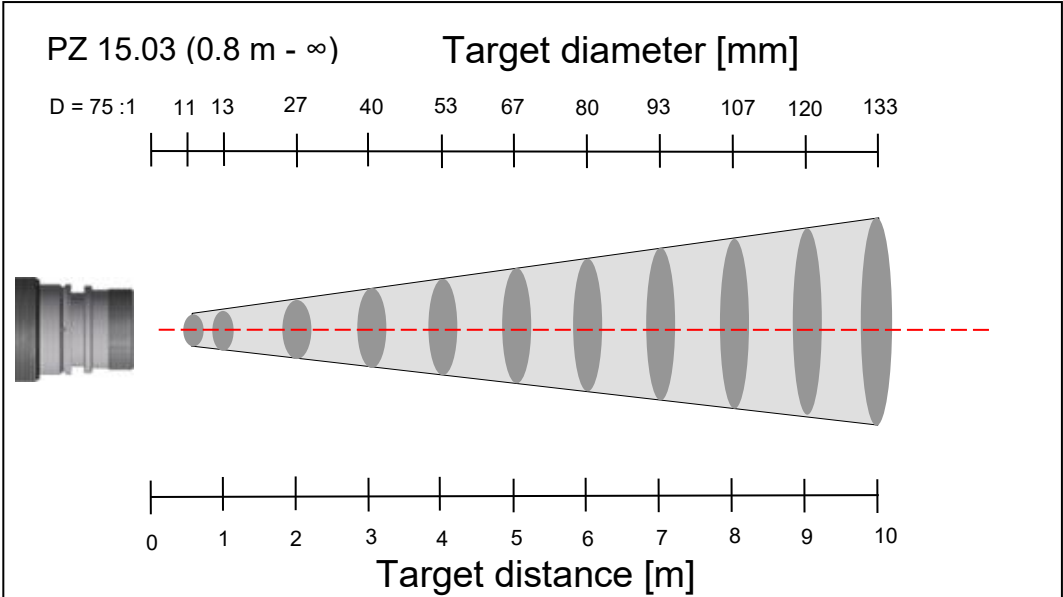

24 Technical Data PA 18

<p>Measuring ranges: (adjustable in partial ranges): 500 - 2500 °C</p>	<p>Ambient operating temperature: 0 - 65 °C</p>	<p>Connection: with 8-pin connector</p>
<p>Sensor: Thermopile</p>	<p>Indication of Overheating: If the internal temperature of the pyrometer exceeds 80 °C the analogue output will show a value > 20.5 mA</p>	<p>Protection: IP 65 according to DIN 40050 (with connector attached)</p>
<p>Spectral sensitivity: Hot combustion gas</p>	<p>Storage temperature: -20 - 80 °C</p>	<p>Adjustable parameters:</p>
<p>Focussing range: 0.8 m - ∞</p>	<p>Permissible humidity: 95% r.H. max. (non-condensing)</p>	<p>Analogue output 1 & 2: source/ scaling</p>
<p>Distance to target size ratio: 70:1 at 800 mm</p>	<p>Temperature coefficient with reference to 23 °C: ≤ 0.04 %/K</p>	<p>Digital input output 1 & 2: source/ switch point</p>
<p>Digital output: Periodic output of measurement data with adjustable cycle time</p>	<p>Interface: USB / RS485 with integrated software to set parameters and transmit measurement data to a PC</p>	<p>Transmission factor</p>
<p>Analogue output 1 & 2: 0(4) - 20 mA linear, switchable, scalable (4 - 20 mA normally)</p>	<p>Analogue input: 0 - 10 V</p>	<p>Compensation of background radiation</p>
<p>Resistance: max. 500 Ω</p>	<p>Digital output: 2 Open collector outputs 24 V; ≤ 30 mA</p>	<p>Look-up table for temperature alignment</p>
<p>Response time t₉₀: ≤ 100 ms</p>	<p>Digital input: 2 to 24 V</p>	<p>Emissivity ε: 10 - 110 % increment size 0.1 %</p>
<p>Resolution Analogue output: 0.2 K + 0.03 % of the adjusted span</p>	<p>Power supply requirements: 24 V DC +10% / -20% current input ≤135 mA / ≤175 mA with camera, 150 mA with switched on spotlight Ripple: ≤ 200 mV</p>	<p>Smoothing function t₉₈: 0 – 999 sec</p>
<p>Resolution Display: 1 K</p>	<p>Dimensions: Ø 65 x 220 mm (with connector attached)</p>	<p>Memory modes: - Min./Max. (peak picker) - Double maximum with adjustable hold time</p>
<p>Resolution USB / RS 485: 0.1 K at terminal operation</p>	<p>Housing material: Stainless steel</p>	<p>Optional accessories: calibration certificate according to ISO 9001 calibration certificate according to DKD large variety of mounting devices, digital displays, software, etc.</p>
<p>Measuring uncertainty: 0.75 % of reading (at ε =1.0 and TA=23 °C)</p>	<p>Mounting: External thread M 65 x 2 length 40 mm</p>	
<p>Linearisation: digital via microcontroller</p>	<p>Weight: Approx. 0.9 kg</p>	
<p>Repeatability: 2 K</p>		
<p>Sighting device: through-the-lens sighting with target marking, laser spotlight or integrated camera</p>		

24.1 Field of View Diagram for PA 18

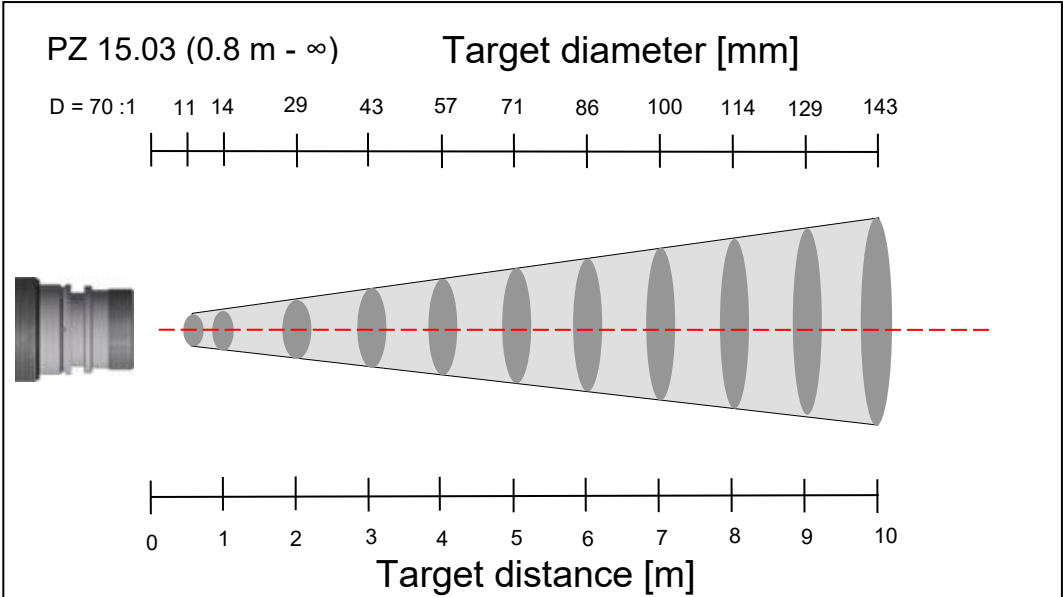

25 Technical Data PA 20

<p>Measuring ranges: (adjustable in partial ranges) 250 - 2000 °C</p> <p>Sensors: photo diode</p> <p>Spectral sensitivity: 1.1 - 1.7 µm</p> <p>Focussing range: 0.4 m - ∞ (Optic PZ 20.01) 0.2 - 0.4 m (Optic PZ 20.03) 1.2 m - ∞ (Optic PZ 20.06) 0.6 m - ∞ (Optic PA 20.06) 0.2 m - ∞ (Optic PZ 20.05)</p> <p>Distance to target-size ratio: 150:1 at 400 mm (Optic PZ 20.03) 175:1 at 400 mm (Optic PZ 20.01) 275:1 at 1200 mm (Optic PZ 20.06) 380:1 at 600 mm (Optic PA 20.06) 40:1 (Optic PZ 20.05)</p> <p>Digital output: Periodic output of measurement data with adjustable cycle time</p> <p>Analogue output 1 & 2: 0(4) - 20 mA linear, switchable, scalable, output insulated from power supply (4 - 20 mA normally)</p> <p>Resistance: max. 500 Ω</p> <p>Response time t_{98}: ≤ 50 ms (T > 250 °C) ≤ 2 ms (T > 750 °C)</p> <p>Resolution Analogue output: 0.2 K + 0.03 % of the adjusted span</p> <p>Resolution Display: 1 K</p> <p>Resolution USB / RS 485: 0.1 K at terminal operation</p> <p>Measuring uncertainty: 0.3 % of reading, min. 4 K (at ε = 1.0 and T_A = 23 °C)</p>	<p>Linearisation: digital via microcontroller</p> <p>Repeatability: 1 K</p> <p>Sighting device: through-the-lens sighting with target marking, laser spotlight or integrated camera</p> <p>Ambient operating temperature: 0 - 65 °C</p> <p>Indication of Overheating: If the internal temperature of the pyrometer exceeds 80 °C the analogue output will show a value > 20.5 mA.</p> <p>Storage temperature: -20 - 80 °C</p> <p>Permissible humidity: 95% r.H. max. (non-condensing)</p> <p>Temperature coefficient with reference to 23 °C: 0.25 K / K (for T < 500 °C) 0.05 % / K (for T ≥ 200 °C) of measured value</p> <p>Interface: USB / RS485 with integrated software to set parameters and transmit measurement data to a PC</p> <p>Analogue input: 0 - 10 V</p> <p>Digital output: 2 Open collector outputs 24 V; ≤ 30 mA</p> <p>Digital input: 2 to 24 V</p> <p>Power supply requirements: 24 V DC +10% / -20% current input ≤ 135 mA / ≤ 175 mA with camera, 150 mA with switched on spotlight Ripple: ≤ 200 mV</p>	<p>Dimensions: Ø 65 x 220 mm (with connector attached)</p> <p>Housing material: Stainless steel</p> <p>Mounting: External thread M 65 x 2 length 40 mm</p> <p>Weight: Approx. 0.9 kg</p> <p>Connection: with 8-pin connector</p> <p>Protection: IP 65 according to DIN 40050 (with connector attached)</p> <p>Adjustable parameters:</p> <p>Analogue output 1 & 2: source/ scaling</p> <p>Digital input output 1 & 2: source/ switch point</p> <p>Transmission factor</p> <p>Compensation of background radiation</p> <p>Look-up table for temperature alignment</p> <p>Emissivity ε: 10 - 110 % increment size 0.1 %</p> <p>Smoothing function t_{98}: 0 - 999 sec</p> <p>Memory modes: - Min./Max. (peak picker) - Double maximum with adjustable hold time</p> <p>Optional accessories: calibration certificate according to ISO 9001 calibration certificate according to DKD large variety of mounting devices, digital displays, software, etc.</p>
--	---	--

25.1 Field of View Diagrams for PA 20

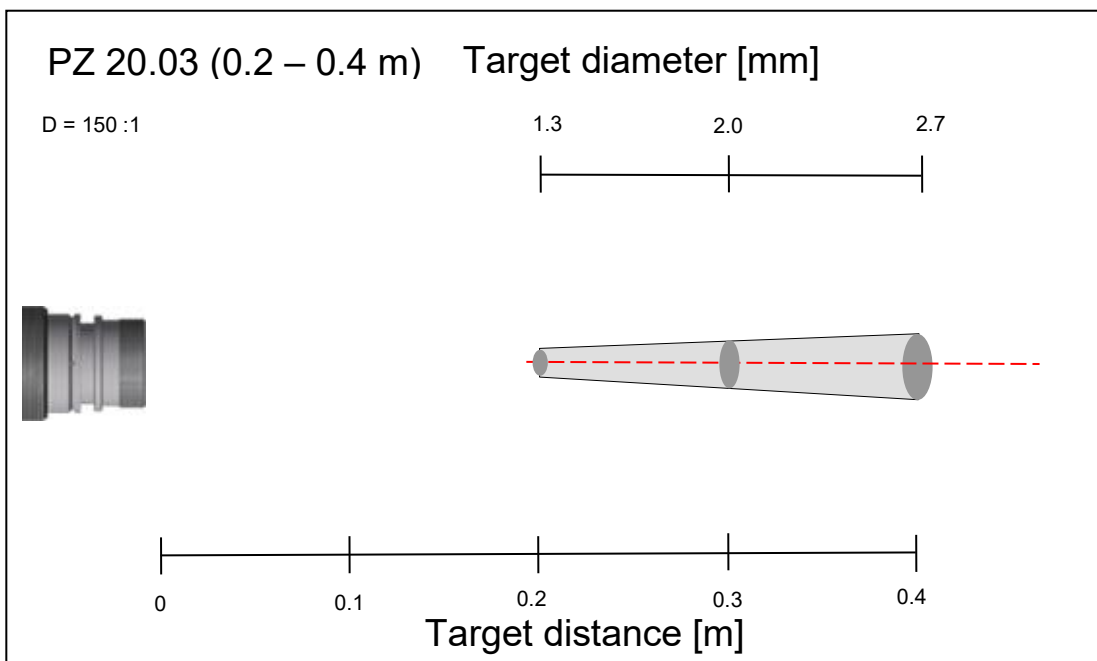
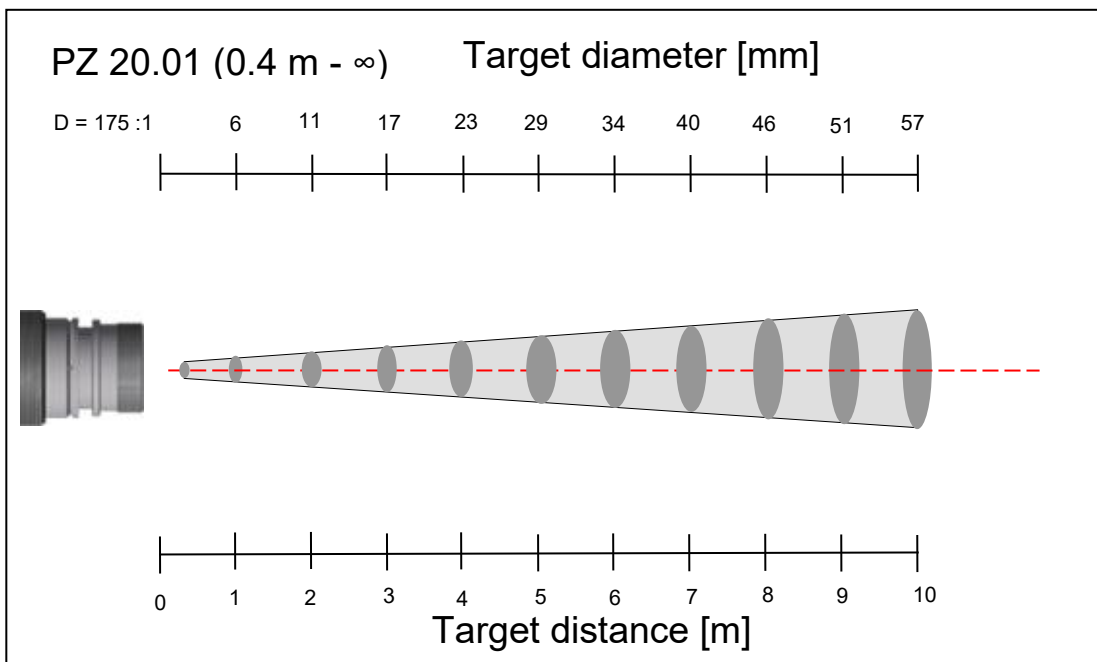

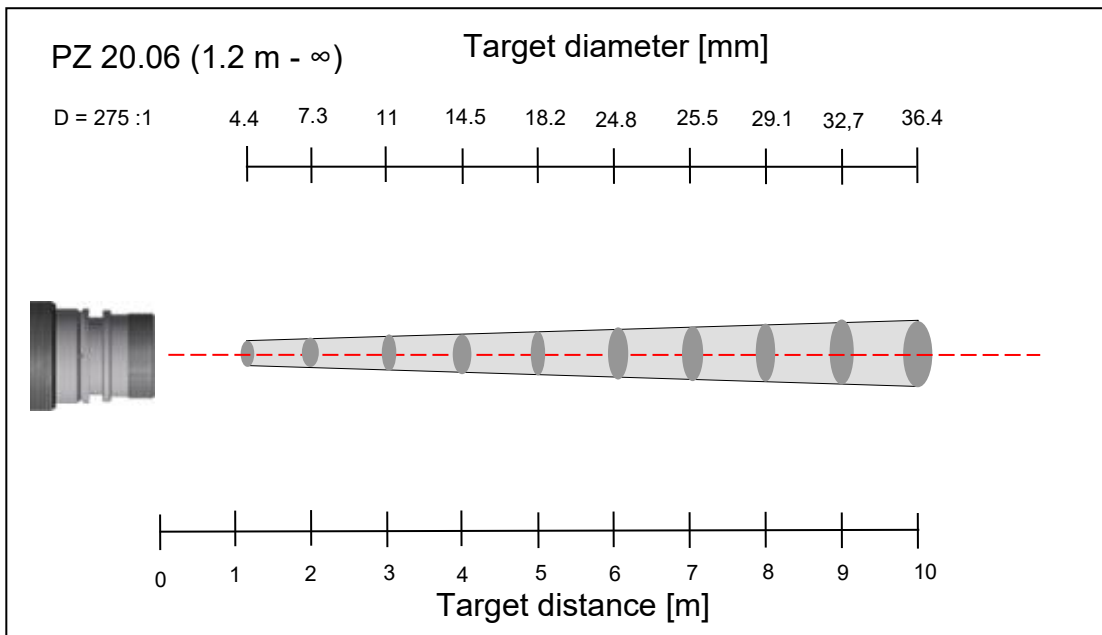
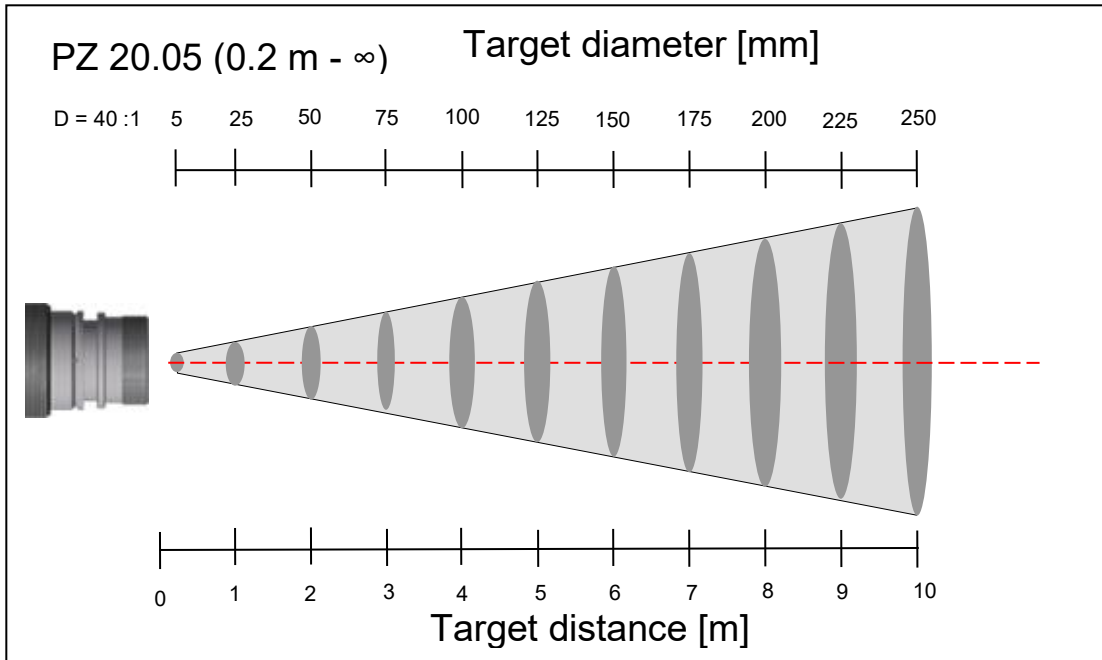

26 Technical Data PA 28

Measuring ranges: (adjustable in partial ranges) 75 - 650 °C	Sighting device: through-the-lens sighting with target marking, laser spotlight or integrated camera	Housing material: Stainless steel
Sensors: photo diode	Ambient operating temperature: 0 - 50 °C	Mounting: External thread M 65 x 2 length 40 mm
Spectral sensitivity: 1.8 – 2.4 µm	Indication of Overheating: If the internal temperature of the pyrometer exceeds 80 °C the analogue output will show a value > 20.5 mA.	Weight: Approx. 0.9 kg
Focussing range: 0.3 m - ∞ (F50 lens)	Storage temperature: -20 - 80 °C	Connection: with 8-pin connector
Distance to target-size ratio: 48 : 1 at 300 mm (F50 lens)	Permissible humidity: 95% r.H. max. (non-condensing)	Protection: IP 65 according to DIN 40050 (with connector attached)
Digital output: Periodic output of measurement data with adjustable cycle time	Temperature coefficient with reference to 23 °C: 0.25 K / K (for T < 500 °C) 0.05 % / K (for T ≥ 500 °C) of measured value	Adjustable parameters
Analogue output 1 & 2: 0(4) - 20 mA linear, switchable, scalable, output insulated from power supply (4 - 20 mA normally)	Interface: USB / RS485 with integrated software to set parameters and transmit measurement data to a PC	Analogue output 1 & 2: source/ scaling
Resistance: max. 500 Ω	Analogue input: 0 - 10 V	Digital input output 1 & 2: source/ switch point
Response time t₉₈: ≤ 200 ms (T > 75 °C) ≤ 50 ms (T > 100 °C) ≤ 15 ms (T > 125 °C) ≤ 2 ms (T > 200 °C)	Digital output: 2 Open collector outputs 24 V; ≤ 30 mA	Transmission factor
Resolution Analogue output: 0.2 K + 0.03 % of the adjusted span	Digital input: 2 to 24 V	Compensation of background radiation
Resolution Display: 0.1 K < 200 °C 1 K ≥ 200 °C	Power supply requirements: 24 V DC +10% / -20% current input ≤135 mA / ≤135 mA with camera, 150 mA with switched on spotlight Ripple: ≤ 200 mV	Look-up table for temperature alignment
Resolution USB / RS 485: 0.1 K at terminal operation	Dimensions: Ø 65 x 220 mm (with connector attached)	Emissivity ε: 10 - 110 % increment size 0.1 %
Measuring uncertainty: 0.75 % of reading, min 3 K (ε = 1.0 and T _A = 23 °C)		Smoothing function t₉₈: 0 - 999 sec
Linearisation: digital via microcontroller		Memory modes: - Min./Max. (peak picker) - Double maximum with adjustable hold time
Repeatability: 1 K		Optional accessories: calibration certificate according to ISO 9001 calibration certificate according to DKD large variety of mounting devices, digital displays, software, etc.

26.1 Relation to the ambient temperature and the emissivity

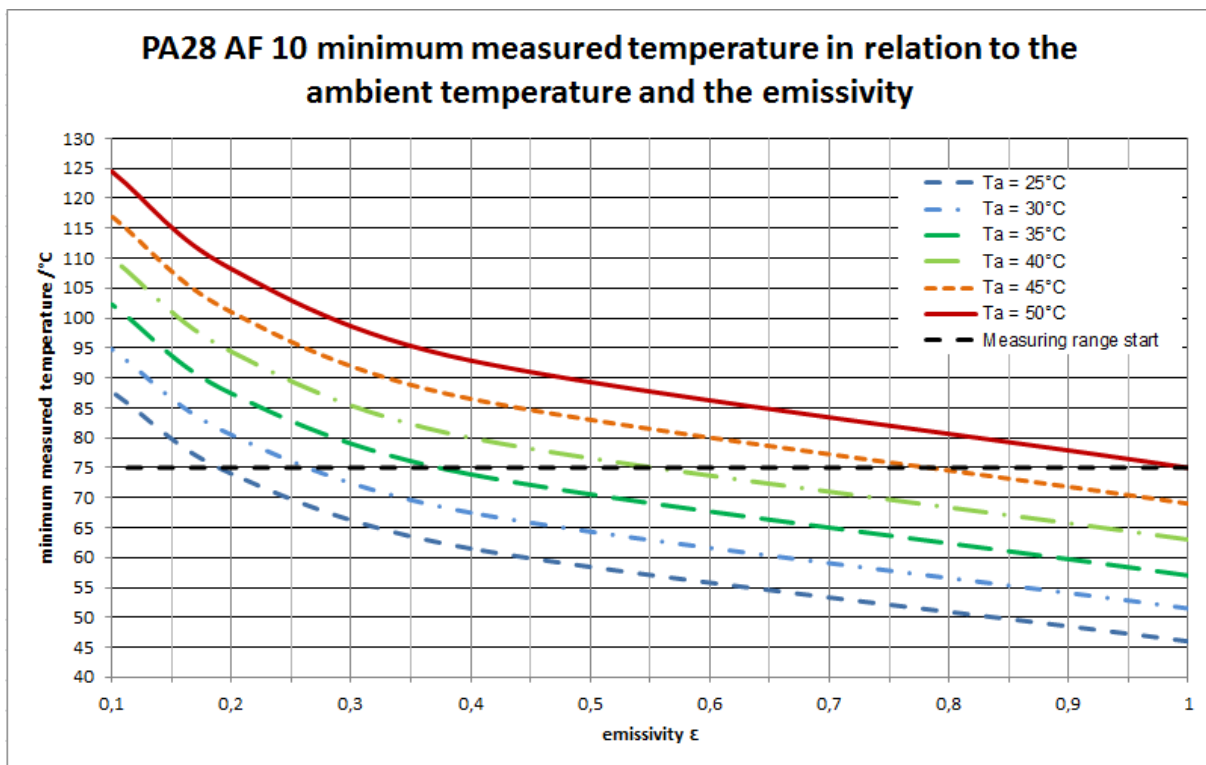

26.2 Field of View Diagram for PA 28

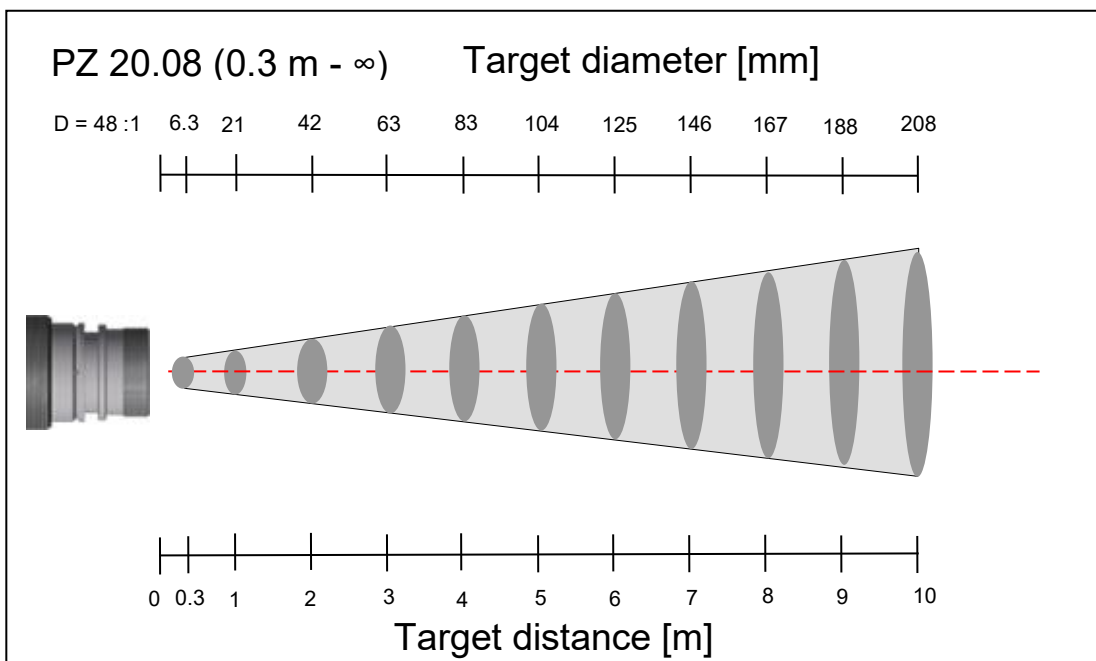

27 Technical Data PA 29 (150 ... 800 °C)

Measuring ranges:
(adjustable in partial ranges)
150 - 800 °C

Sensors:
photo diode

Spectral sensitivity:
1.8 – 2.2 μm

Focussing range:
0.3 m - ∞ (F50 lens)

Distance to target-size ratio:
48 : 1 at 300 mm (F50 lens)

Digital output:
Periodic output of measurement data with adjustable cycle time

Analogue output 1 & 2:
0(4) ... 20 mA linear, switchable, scalable, output insulated from power supply (4...20 mA normally)

Resistance:
max. 500 Ω

Response time t_{98} :
 ≤ 50 ms ($T > 150$ °C)
 ≤ 2 ms ($T > 200$ °C)
 ≤ 2 ms ($T > 350$ °C)

Resolution Analogue output:
0.2 K + 0.03 % of the adjusted span

Resolution Display:
0.1 K < 200 °C
1 K \geq 200 °C

Resolution USB / RS 485:
0.1 K at terminal operation

Measuring uncertainty:
0.75 % of reading, min 5 K ($\epsilon = 1.0$ and $T_A = 23$ °C)

Linearisation:
digital via microcontroller

Repeatability:
1 K

Sighting device:
through-the-lens sighting with target marking, laser spotlight or integrated camera

Ambient operating temperature:
0 - 65 °C

Indication of Overheating:
If the internal temperature of the pyrometer exceeds 80 °C the analogue output will show a value > 20.5 mA.

Storage temperature:
-20 - 80 °C

Permissible humidity:
95% r.H. max.
(non-condensing)

Temperature coefficient with reference to 23 °C:
0.25 K / K (for $T < 500$ °C)
0.05 % / K (for $T \geq 500$ °C)
of measured value

Interface:
USB / RS485 with integrated software to set parameters and transmit measurement data to a PC

Analogue input:
0 - 10 V

Digital output:
2 Open collector outputs
24 V; ≤ 30 mA

Digital input:
2 to 24 V

Power supply requirements:
24 V DC +10% / -20%
current input ≤ 135 mA / ≤ 135 mA with camera, 150 mA with switched on spotlight
Ripple: ≤ 200 mV

Dimensions:
 $\varnothing 65 \times 220$ mm
(with connector attached)

Housing material:
Stainless steel

Mounting:
External thread M 65 x 2
length 40 mm

Weight:
Approx. 0.9 kg

Connection:
with 8-pin connector

Protection:
IP 65 according to
DIN 40050
(with connector attached)

Adjustable parameters

Analogue output 1 & 2:
source/ scaling

Digital input output 1 & 2:
source/ switch point

Transmission factor

Compensation of background radiation

Look-up table for temperature alignment

Emissivity ϵ :
10 - 110 %
increment size 0.1 %

Smoothing function t_{98} :
0 - 999 sec

Memory modes:
- Min./Max. (peak picker)
- Double maximum with adjustable hold time

Optional accessories:
calibration certificate according to ISO 9001

calibration certificate according to DKD

large variety of mounting devices, digital displays, software, etc.

27.1 Field of View Diagram for PA 29

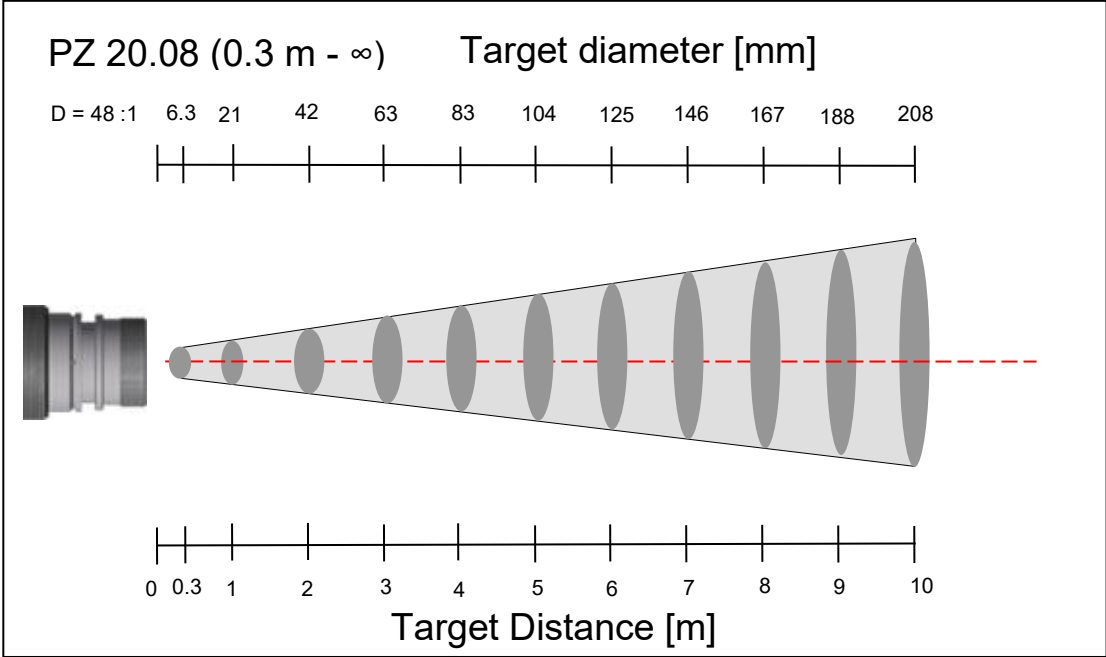

28 Technical Data PA 29 (180 ... 1200 °C)

Measuring ranges: (adjustable in partial ranges) 180 - 1200 °C	Repeatability: 1 K	Housing material: Stainless steel
Sensors: photo diode	Sighting device: through-the-lens sighting with target marking, laser spotlight or integrated camera	Mounting: External thread M 65 x 2 length 40 mm
Spectral sensitivity: 1.8 – 2.2 µm	Ambient operating temperature: 0 - 65 °C	Weight: Approx. 0.9 kg
Focussing range: 0.2 - 0.4 m (close-up lens) 0.4 m - ∞ (standard lens) 1.2 m - ∞ (telephoto lens)	Indication of Overheating: If the internal temperature of the pyrometer exceeds 80 °C the analogue output will show a value > 20.5 mA.	Connection: with 8-pin connector
Distance to target-size ratio: 56 : 1 at 400 mm (Close-up) 60 : 1 at 400 mm (standard) 96 : 1 at 1200 mm (tele-lens)	Storage temperature: -20 - 80 °C	Protection: IP 65 according to DIN 40050 (with connector attached)
Digital output: Periodic output of measurement data with adjustable cycle time	Permissible humidity: 95% r.H. max. (non-condensing)	Adjustable parameters
Analogue output 1 & 2: 0(4) - 20 mA linear, switchable, scalable, output insulated from power supply (4 - 20 mA normally)	Temperature coefficient with reference to 23 °C: 0.25 K / K (for T < 500 °C) 0.05 % / K (for T ≥ 500 °C) of measured value	Analogue output 1 & 2: source/ scaling
Resistance: max. 500 Ω	Interface: USB / RS485 with integrated software to set parameters and transmit measurement data to a PC	Digital input output 1 & 2: source/ switch point
Response time t₉₈: ≤ 75 ms (T>180 °C) ≤ 35 ms (T>200 °C) ≤ 5 ms (T>300 °C) ≤ 2 ms (T>600 °C)	Analogue input: 0 - 10 V	Transmission factor
Resolution Analogue output: 0.2 K + 0.03 % of the adjusted span	Digital output: 2 Open collector outputs 24 V; ≤ 30 mA	Compensation of background radiation
Resolution Display: 0.1 K < 200 °C 1 K ≥ 200 °C	Digital input: 2 to 24 V	Look-up table for temperature alignment
Resolution USB / RS 485: 0.1 K at terminal operation	Power supply requirements: 24 V DC +10% / -20% current input ≤135 mA / ≤135 mA with camera, 150 mA with switched on spotlight Ripple: ≤ 200 mV	Emissivity ε: 10 - 110 % increment size 0.1 %
Measuring uncertainty: 0.75 % of reading, min. 5 K (ε = 1.0 and T _A =23 °C)	Dimensions: Ø 65 x 220 mm (with connector attached)	Smoothing function t₉₈: 0 - 999 sec
Linearisation: digital via microcontroller		Memory modes: - Min./Max. (peak picker) - Double maximum with adjustable hold time
		Optional accessories: calibration certificate according to ISO 9001 calibration certificate according to DKD large variety of mounting devices, digital displays, software, etc.

28.1 Field of View Diagrams for PA 29

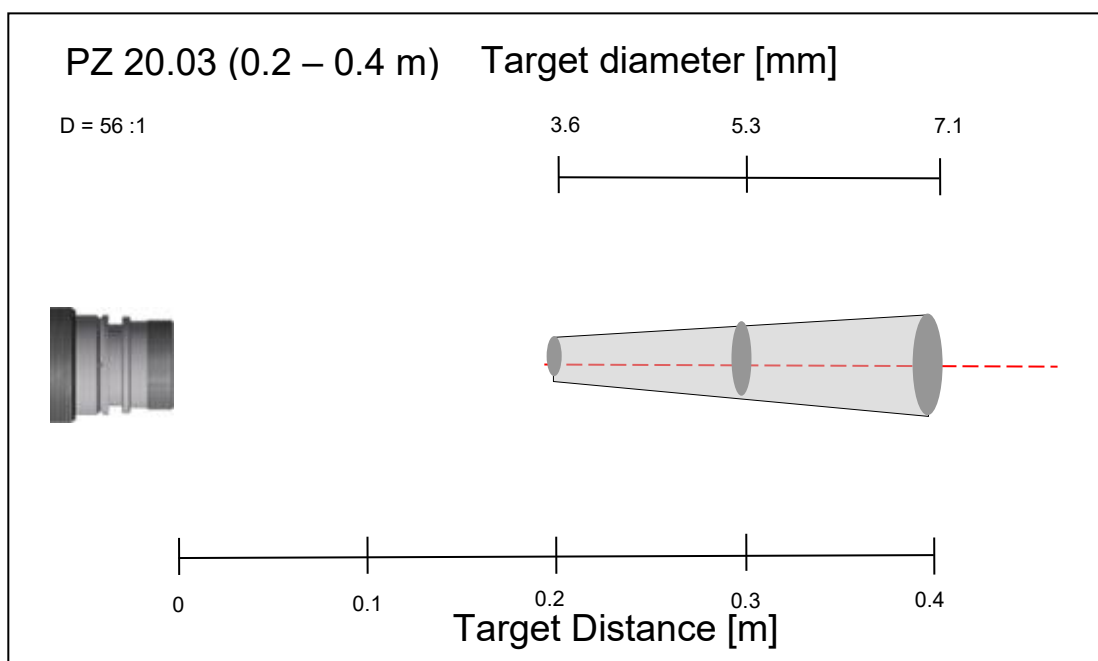
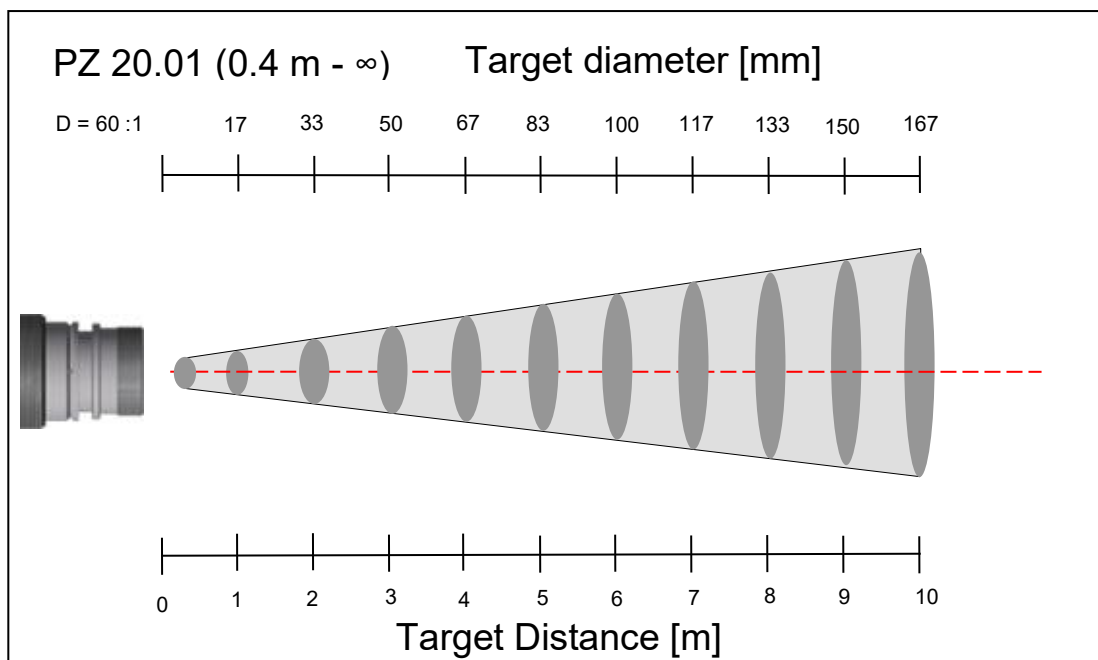

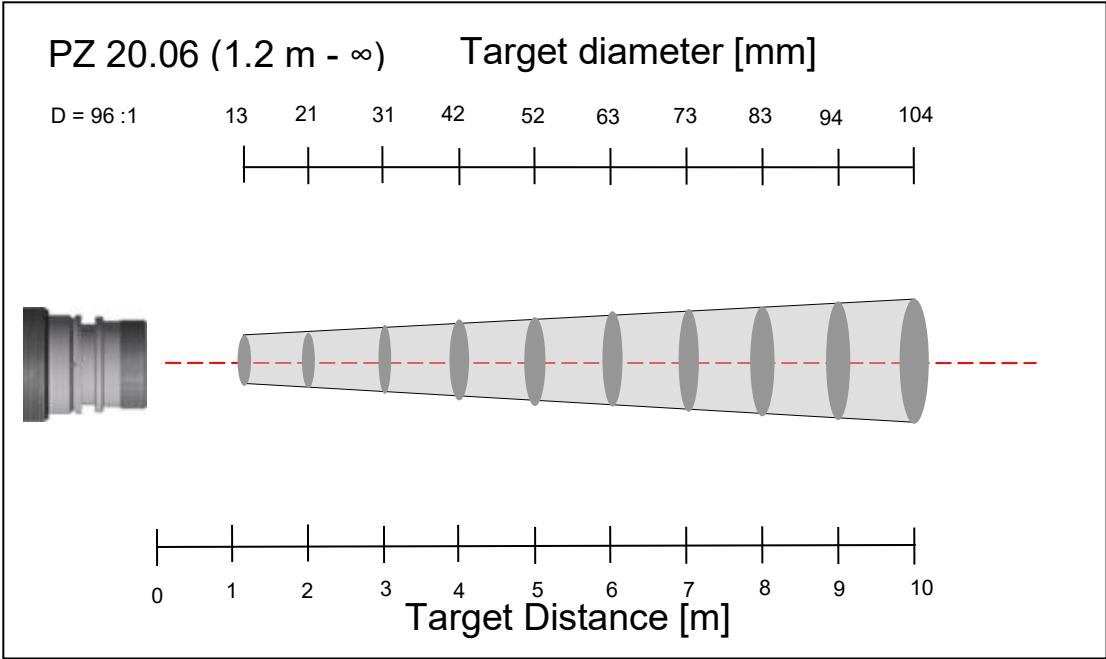

29 Technical Data PA 29 (250 ... 2000 °C, 350 ... 2500 °C)

Measuring ranges:

(adjustable in partial ranges)
I: 250 - 2000 °C
II: 350 - 2500 °C

Sensors:

photo diode

Spectral sensitivity:

1.8 – 2.2 μm

Focussing range:

0.2 - 0.4 m (close-up lens)
0.4 m - ∞ (standard lens)
0.2 m - ∞ (wide-angle lens)
1.2 m - ∞ (telephoto lens)

Distance to target-size ratio:

200 : 1 at 400 mm (Close-up)
210 : 1 at 400 mm (standard)
310 : 1 at 1200 mm (tele-lens)
55 : 1 at 400 mm (wide angle)

Digital output:

Periodic output of measurement data with adjustable cycle time

Analogue output 1 & 2:

0(4) - 20 mA linear, switchable, scalable, output insulated from power supply (4 - 20 mA normally)

Resistance:

max. 500 Ω

Response time t_{98} :

Measuring ranges I:
≤ 50 ms (T > 250 °C)
≤ 2 ms (T > 750 °C)
Measuring ranges II:
≤ 50 ms (T > 350 °C)
≤ 2 ms (T > 900 °C)

Resolution Analogue output:

0.2 K + 0.03 % of the adjusted span

Resolution Display:

0.1 K < 200 °C
1 K ≥ 200 °C

Resolution USB / RS 485:

0.1 K at terminal operation

Measuring uncertainty:

0.5 % of reading, min 4 K
($\epsilon = 1.0$ and $T_A = 23$ °C)

Linearisation:

digital via microcontroller

Repeatability:

1 K

Sighting device:

through-the-lens sighting with target marking, laser spotlight or integrated camera

Ambient operating temperature:

0 - 65 °C

Indication of Overheating:

If the internal temperature of the pyrometer exceeds 80 °C the analogue output will show a value > 20.5 mA.

Storage temperature:

-20 - 80 °C

Permissible humidity:

95% r.H. max.
(non-condensing)

Temperature coefficient with reference to 23 °C:

0.25 K / K (for T < 500 °C)
0.05 % / K (for T ≥ 500 °C)
of measured value

Interface:

USB / RS485 with integrated software to set parameters and transmit measurement data to a PC

Analogue input:

0 - 10 V

Digital output:

2 Open collector outputs
24 V; ≤ 30 mA

Digital input:

2 to 24 V

Power supply requirements:

24 V DC +10% / -20%
current input ≤ 135 mA / ≤ 175 mA with camera, 150 mA with switched on spotlight
Ripple: ≤ 200 mV

Dimensions:

Ø 65 x 220 mm
(with connector attached)

Housing material:

Stainless steel

Mounting:

External thread M 65 x 2 length 40 mm

Weight:

Approx. 0.9 kg

Connection:

with 8-pin connector

Protection:

IP 65 according to DIN 40050
(with connector attached)

*Adjustable parameters***Analogue output 1 & 2:**

source/ scaling

Digital input output 1 & 2:

source/ switch point

Transmission factor**Compensation of background radiation****Look-up table for temperature alignment****Emissivity ϵ :**

10 - 110 %
increment size 0.1 %

Smoothing function t_{98} :

0 - 999 sec

Memory modes:

- Min./Max. (peak picker)
- Double maximum with adjustable hold time

Optional accessories:

calibration certificate according to ISO 9001

calibration certificate according to DKD

large variety of mounting devices, digital displays, software, etc.

29.1 Field of View Diagrams for PA 29

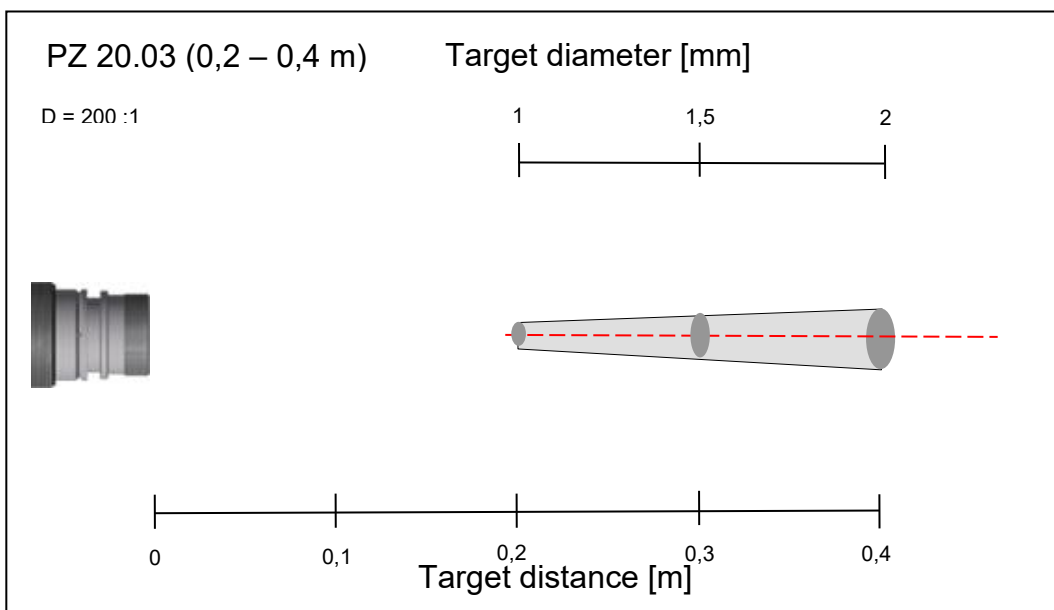
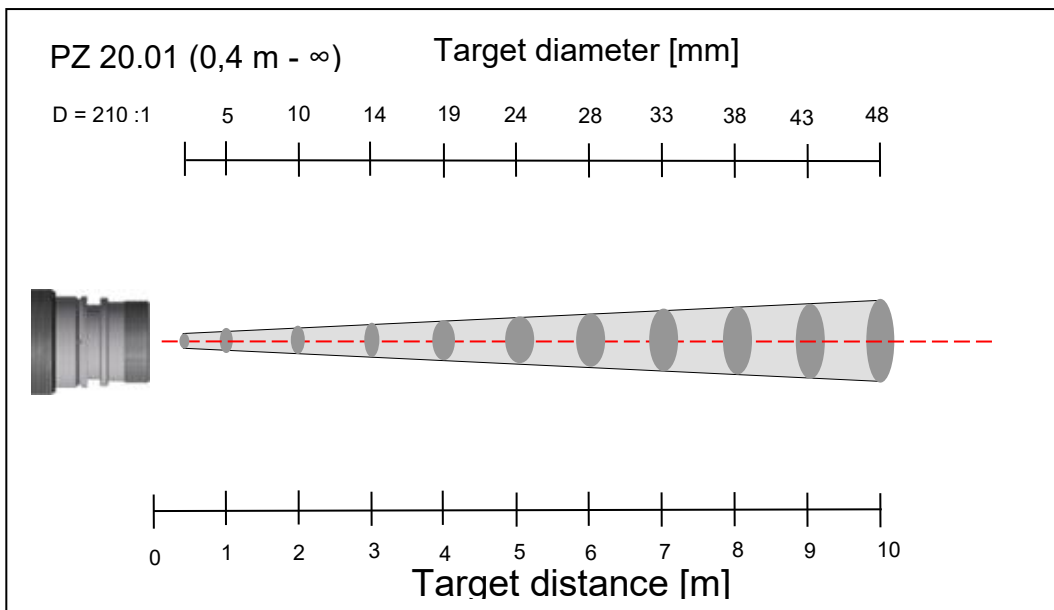

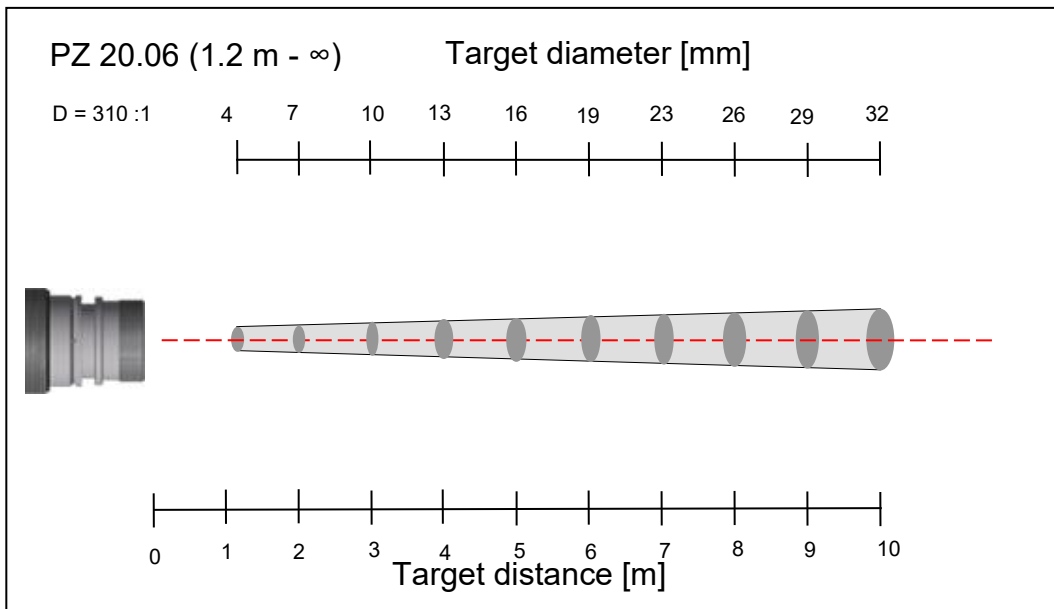
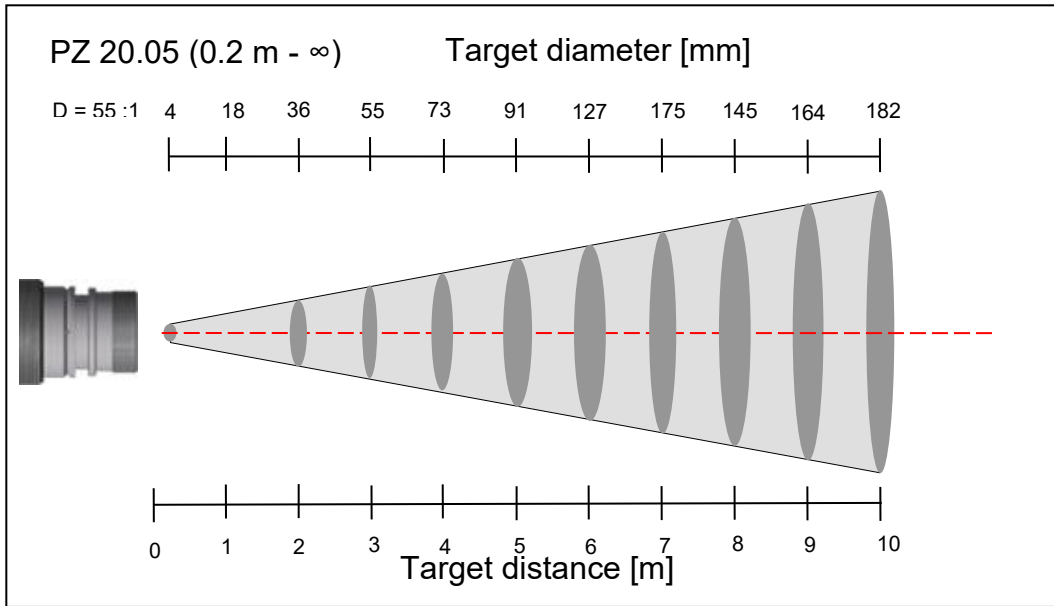

30 Technical Data PA 30

Measuring ranges:

(adjustable in partial ranges)
500 - 2500 °C

Sensors:

photo diode

Spectral sensitivity:

0.78 - 1.06 µm

Focussing range:

0.4 m - ∞ (Optic PZ 20.01)
0.2 - 0.4 m (Optic PZ 20.03)
1.2 m - ∞ (Optic PZ 20.06)
0.6 m - ∞ (Optic PA 20.06)
0.2 m - ∞ (Optic PZ 20.05)

Distance to target-size ratio:

200:1 at 400 mm
(Optic PZ 20.03)
210:1 at 400 mm
(Optic PZ 20.01)
310:1 at 1200 mm
(Optic PZ 20.06)
430:1 at 600 mm
(Optic PA 20.06)
55:1 (Optic PZ 20.05)

Digital output:

Periodic output of measurement data with adjustable cycle time

Analogue output 1 & 2:

0(4) - 20 mA linear, switchable, scalable, output insulated from power supply (4 - 20 mA normally)

Resistance:

max. 500 Ω

Response time t_{98} :

≤ 50 ms (T > 550 °C)
≤ 2 ms (T > 750 °C)

Resolution Analogue output:

0.2 K + 0.03 % of the adjusted span

Resolution Display:

1 K

Resolution USB / RS 485:

0.1 K at terminal operation

Measuring uncertainty:

0.3 % of reading, min 4 K
($\epsilon = 1.0$ and $T_A = 23$ °C)

Linearisation:

digital via microcontroller

Repeatability:

1 K

Sighting device:

through-the-lens sighting with target marking, laser spotlight or integrated camera

Ambient operating temperature:

0 - 65 °C

Indication of Overheating:

If the internal temperature of the pyrometer exceeds 80 °C the analogue output will show a value > 20.5 mA.

Storage temperature:

-20 - 80 °C

Permissible humidity:

95% r.H. max.
(non-condensing)

Temperature coefficient with reference to 23 °C:

0.25 K / K (for T < 500 °C)
0.05 % / K (for T ≥ 200 °C)
of measured value

Interface:

USB / RS485 with integrated software to set parameters and transmit measurement data to a PC

Analogue input:

0 - 10 V

Digital output:

2 Open collector outputs
24 V; ≤ 30 mA

Digital input:

2 to 24 V

Power supply requirements:

24 V DC +10% / -20%
current input ≤ 135 mA / ≤ 175 mA with camera, 150 mA with switched on spotlight
Ripple: ≤ 200 mV

Dimensions:

Ø 65 x 220 mm
(with connector attached)

Housing material:

Stainless steel

Mounting:

External thread M 65 x 2
length 40 mm

Weight:

Approx. 0.9 kg

Connection:

with 8-pin connector

Protection:

IP 65 according to
DIN 40050
(with connector attached)

Adjustable parameters

Analogue output 1 & 2:

source/ scaling

Digital input output 1 & 2:

source/ switch point

Transmission factor

Compensation of background radiation

Look-up table for temperature alignment

Emissivity ϵ :

10 - 110 %
increment size 0.1 %

Smoothing function t_{98} :

0 - 999 sec

Memory modes:

- Min./Max. (peak picker)
- Double maximum with adjustable hold time

Optional accessories:

calibration certificate
according to ISO 9001

calibration certificate
according to DKD

large variety of mounting devices, digital displays, software, etc.

30.1 Field of View Diagrams for PA 30

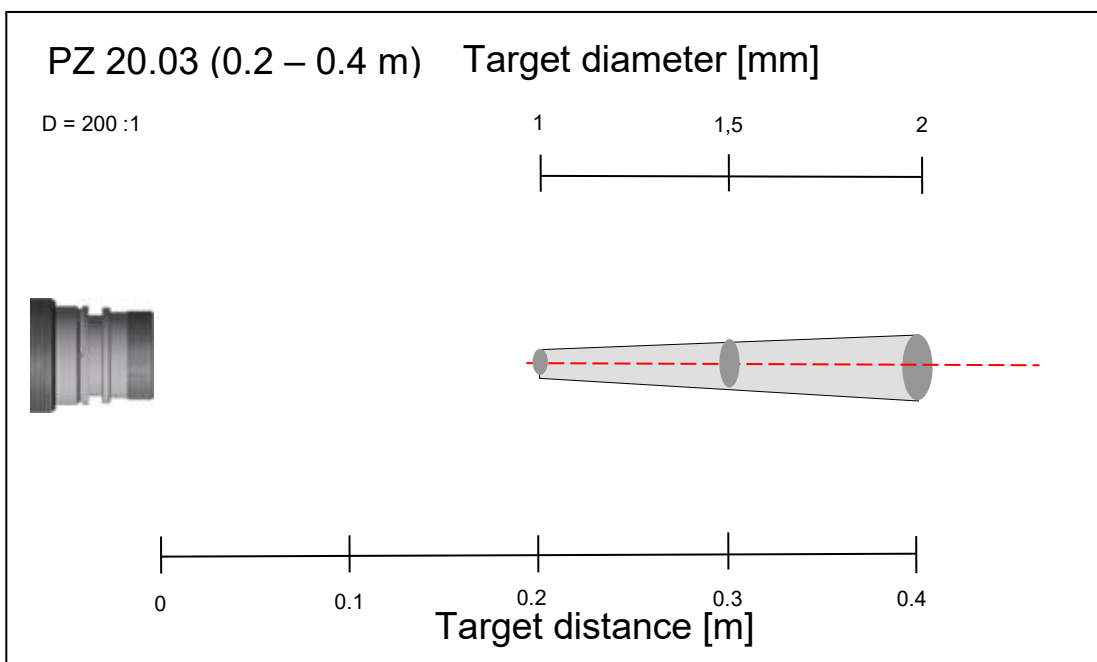
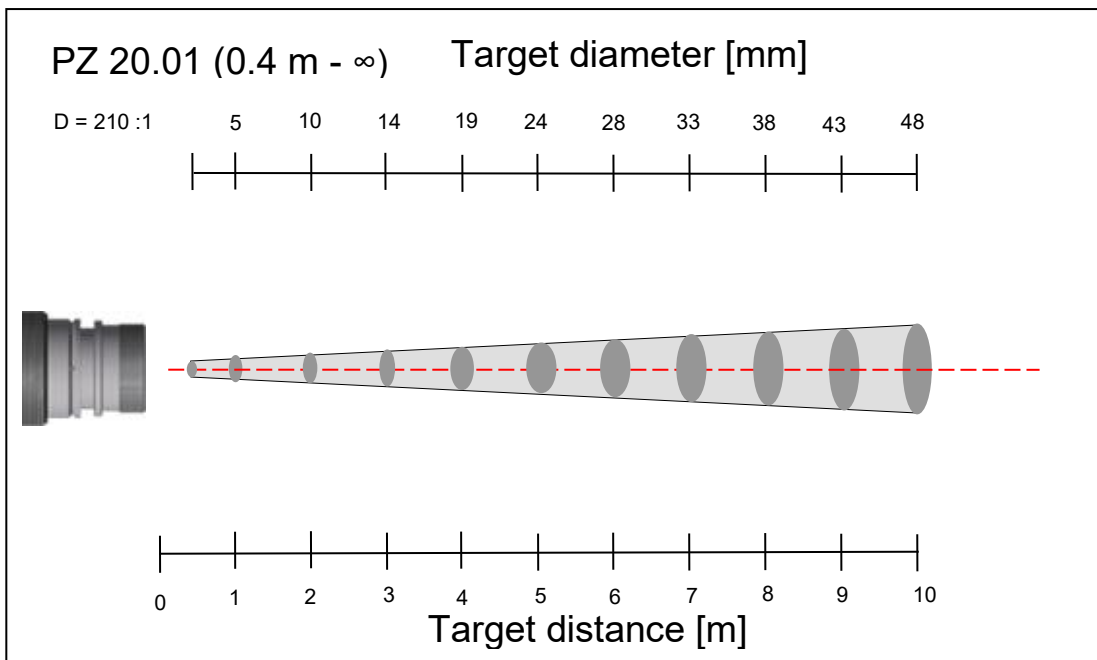

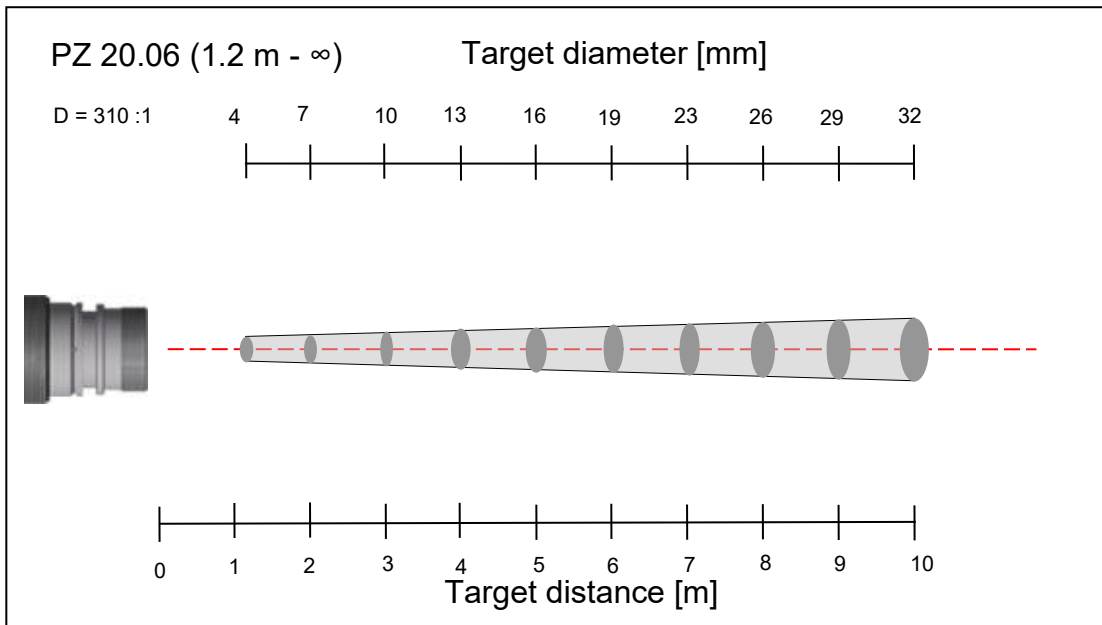
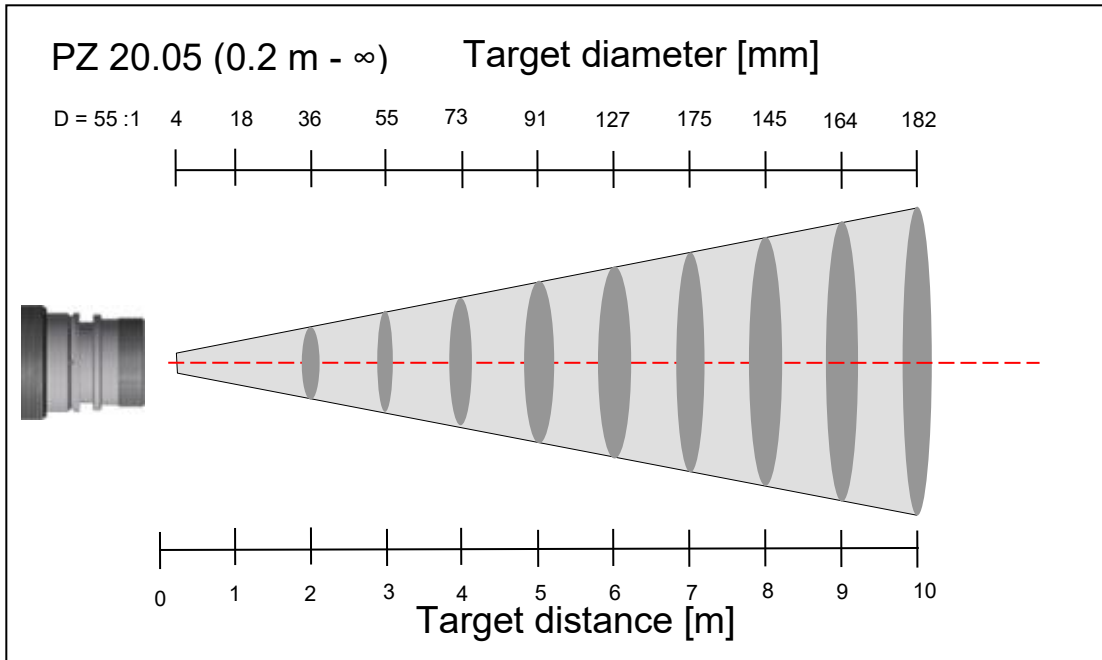

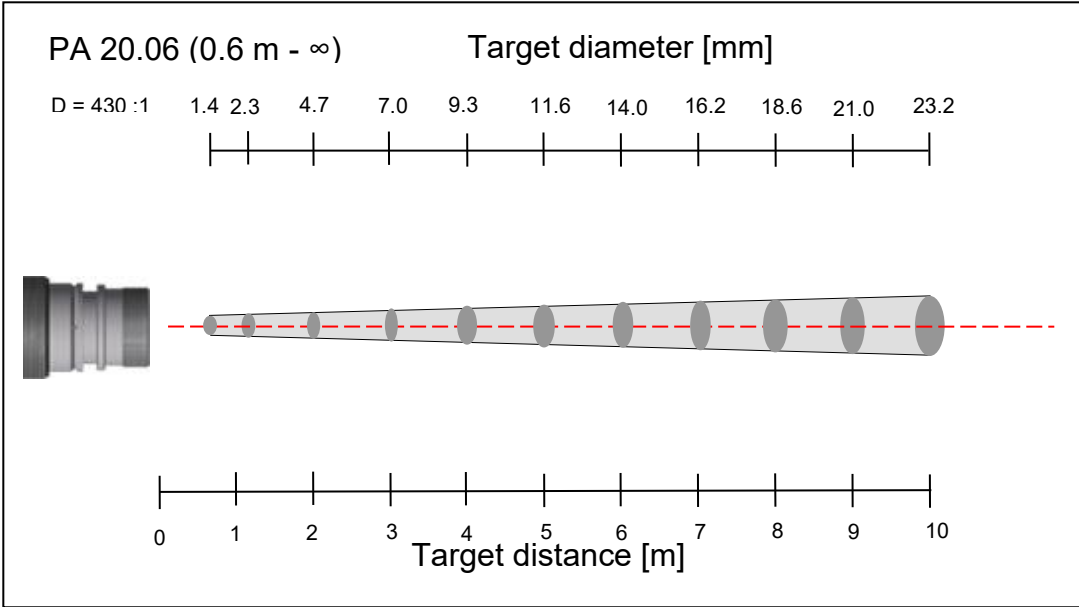

31 Technical Data PA 35

<p>Measuring ranges: 600 - 3000 °C 600 - 3500 °C</p>	<p>Measuring uncertainty: 0,3 % of reading, min 4 K (at $\varepsilon = 1,0$ and $T_u = 23$ °C)</p>	<p>Dimensions: Ø 65 x 220 mm (with connector attached)</p>
<p>Sensors: photo diode</p>	<p>Linearisation: digital via microcontroller</p>	<p>Housing material: Stainless steel</p>
<p>Spectral sensitivity: 0.82 – 0.93 µm</p>	<p>Repeatability: 1 K</p>	<p>Mounting: External thread M 65 x 2 length 40 mm</p>
<p>Focussing range: 0.4 m - ∞ (Optic PZ 20.01) 0.2 - 0.4 m (Optic PZ 20.03) 1.2 m - ∞ (Optic PZ 20.06) 0.6 m - ∞ (Optic PA 20.06) 0.2 m - ∞ (Optic PZ 20.05)</p>	<p>Sighting device: through-the-lens sighting with target marking, laser spotlight or integrated camera</p>	<p>Weight: Approx. 0.9 kg</p>
<p>Distance to target-size ratio: 200:1 at 400 mm (Optic PZ 20.03) 210:1 at 400 mm (Optic PZ 20.01) 310:1 at 1200 mm (Optic PZ 20.06) 430:1 at 600 mm (Optic PA 20.06) 55:1 (Optic PZ 20.05)</p>	<p>Ambient operating temperature: 0 - 65 °C</p>	<p>Connection: with 8-pin connector</p>
<p>Digital output: Periodic output of measure- ment data with adjustable cycle time</p>	<p>Indication of Overheating: If the internal temperature of the pyrometer exceeds 80 °C the analogue output will show a value > 20.5 mA.</p>	<p>Protection: IP 65 according to DIN 40050 (with connector attached)</p>
<p>Analogue output 1 & 2: 0(4) - 20 mA linear, switchable, scalable, output insulated from power supply (4 - 20 mA normally)</p>	<p>Storage temperature: -20 - 80 °C</p>	<p>Adjustable parameters</p> <p>Analogue output 1 & 2: source/ scaling</p>
<p>Resistance: max. 500 Ω</p>	<p>Permissible humidity: 95% r.H. max. (non-condensing)</p>	<p>Digital input output 1 & 2: source/ switch point</p>
<p>Response time t_{98}: ≤ 50 ms ($T > 650$ °C) ≤ 2 ms ($T > 850$ °C)</p>	<p>Temperature coefficient with reference to 23 °C: ≤ 0.25 K / K (for $T < 500$ °C) ≤ 0.05 %/K (for $T \geq 500$ °C) of measured value</p>	<p>Transmission factor</p>
<p>Resolution Analogue output: 0.2 K + 0.03 % of the adjusted span</p>	<p>Interface: USB / RS485 with integrated software to set parameters and transmit measurement data to a PC</p>	<p>Compensation of background radiation</p>
<p>Resolution Display: 1 K</p>	<p>Analogue input: 0 - 10 V</p>	<p>Look-up table for temperature alignment</p>
<p>Resolution USB / RS 485: 0.1 K at terminal operation</p>	<p>Digital output: 2 Open collector outputs 24 V; ≤ 30 mA</p>	<p>Emissivity ε: 10 - 110 % increment size 0.1 %</p>
	<p>Digital input: 2 to 24 V</p>	<p>Smoothing function t_{98}: 0 - 999 sec</p>
	<p>Power supply requirements: 24 V DC +10% / -20% current input ≤135 mA / ≤175 mA with camera, 150 mA with switched on spotlight Ripple: ≤ 200 mV</p>	<p>Memory modes: - Min./Max. (peak picker) - Double maximum with adjustable hold time</p>
		<p>Optional accessories: calibration certificate according to ISO 9001</p>
		<p>calibration certificate according to DKD</p>
		<p>large variety of mounting devices, digital displays, software, etc.</p>

31.1 Field of View Diagrams for PA 35

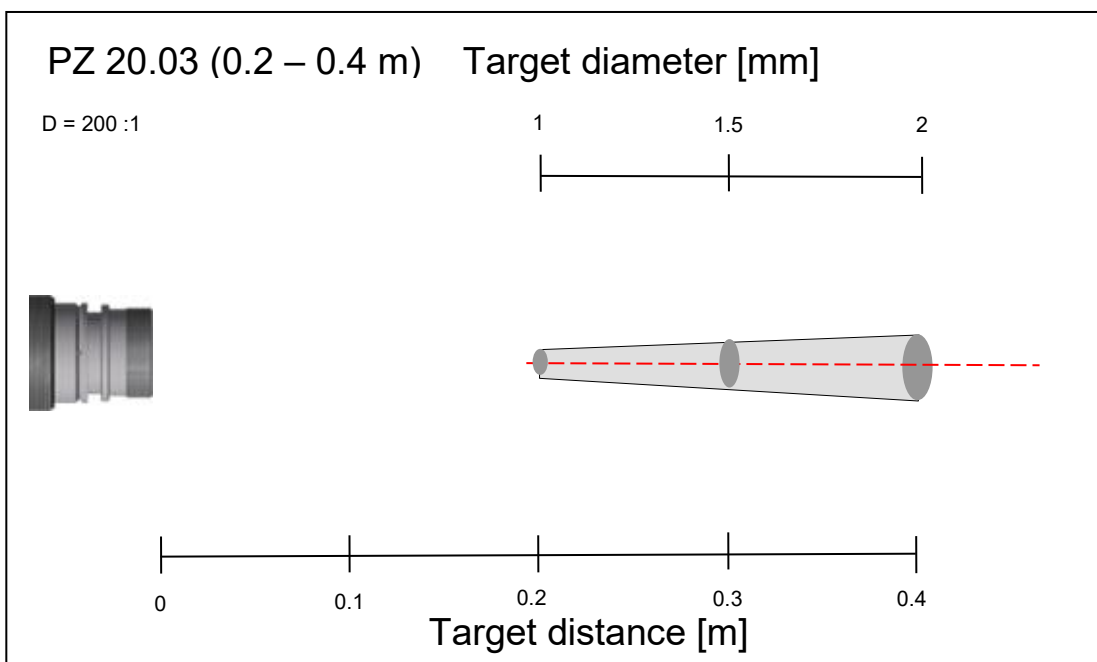
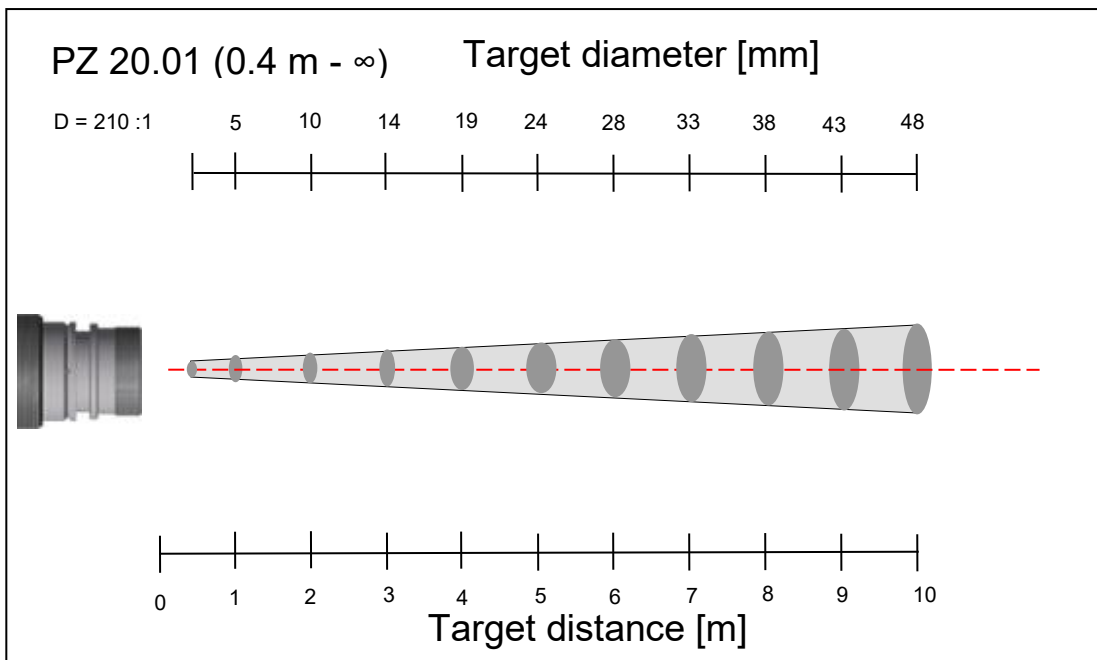

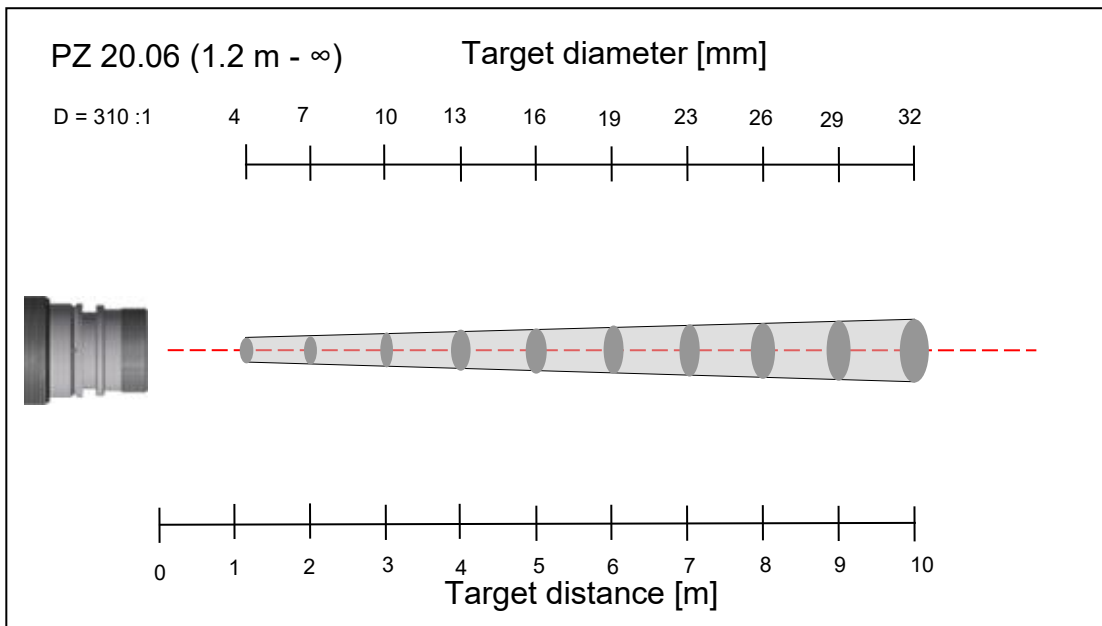
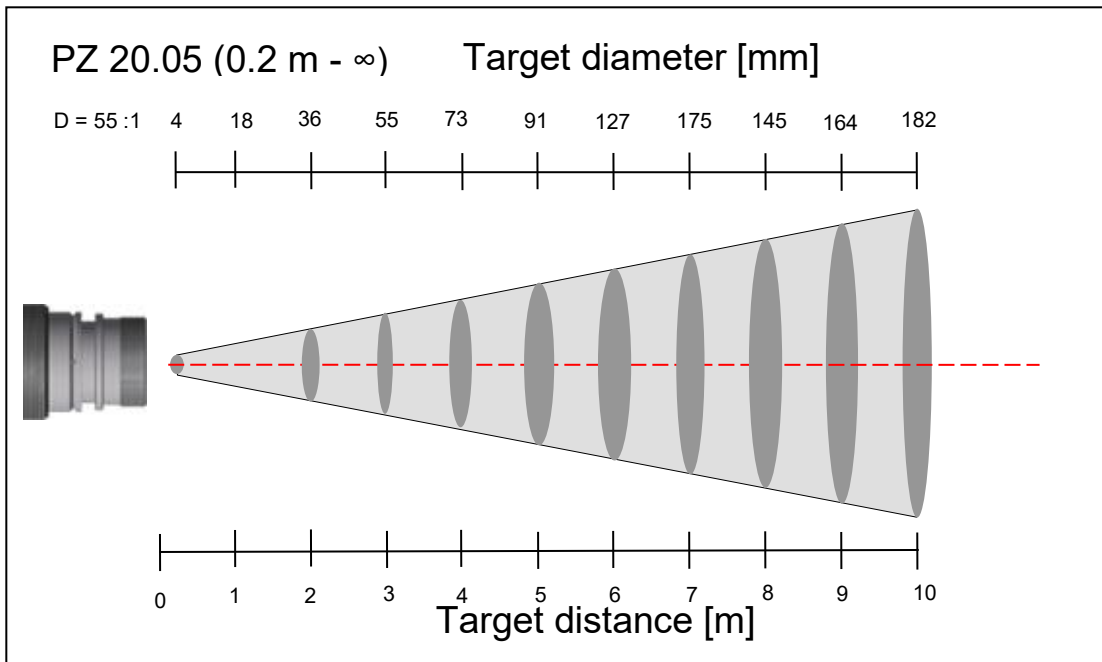

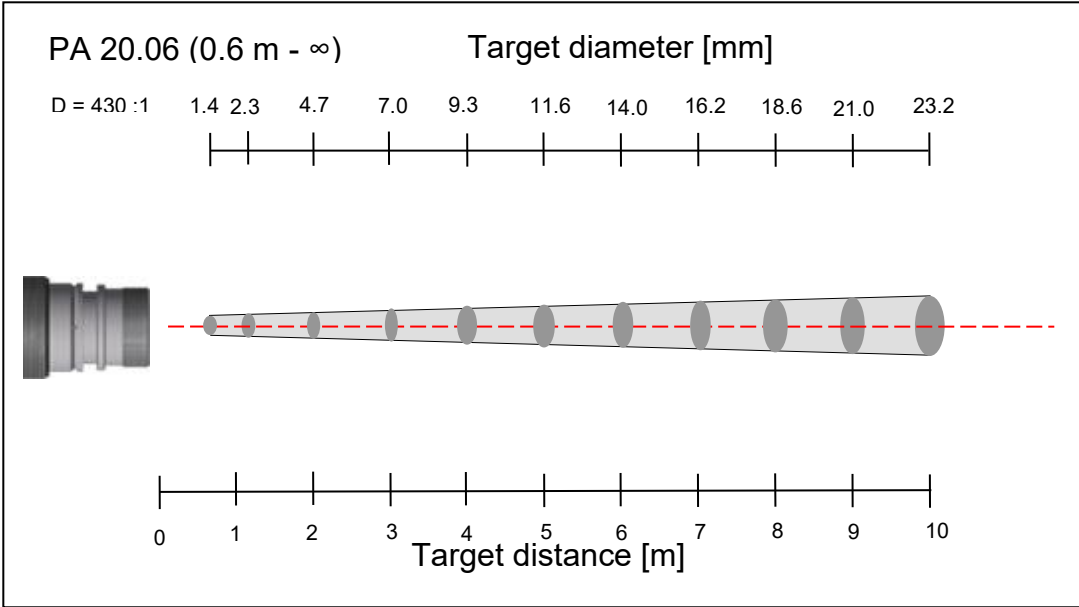

32 Technical Data PA 38 AF 10

<p>Measuring range: 450 - 1800 °C</p> <p>Sensors: photo diode</p> <p>Spectral sensitivity: 0.82 – 0.93 µm</p> <p>Focussing range: 0.3 m - ∞ (Optic PZ 20.08)</p> <p>Distance to target-size ratio: 300:1 at 300 mm</p> <p>Digital output: Periodic output of measurement data with adjustable cycle time</p> <p>Analogue output 1 & 2: 0(4) - 20 mA linear, switchable, scalable, output insulated from power supply (4 - 20 mA normally)</p> <p>Resistance: max. 500 Ω</p> <p>Response time t_{98}: ≤ 50 ms (T > 650 °C) ≤ 2 ms (T > 850 °C)</p> <p>Resolution Analogue output: 0.2 K + 0.03 % of the adjusted span</p> <p>Resolution Display: 1 K</p> <p>Resolution USB / RS 485: 0.1 K at terminal operation</p> <p>Measuring uncertainty: 0,3 % of reading, min 4 K (at $\epsilon = 1,0$ and $T_U = 23$ °C)</p> <p>Linearisation: digital via microcontroller</p> <p>Repeatability: 1 K</p>	<p>Sighting device: through-the-lens sighting with target marking, laser spotlight or integrated camera</p> <p>Ambient operating temperature: 0 ... 65 °C</p> <p>Indication of Overheating: If the internal temperature of the pyrometer exceeds 80 °C the analogue output will show a value > 20.5 mA.</p> <p>Storage temperature: -20 ... 80 °C</p> <p>Permissible humidity: 95% r.H. max. (non-condensing)</p> <p>Temperature coefficient with reference to 23 °C: ≤ 0.25 K / K (for T < 500 °C) ≤ 0.05 %/K (for T ≥ 500 °C) of measured value</p> <p>Interface: USB / RS485 with integrated software to set parameters and transmit measurement data to a PC</p> <p>Analogue input: 0 - 10 V</p> <p>Digital output: 2 Open collector outputs 24 V; ≤ 30 mA</p> <p>Digital input: 2 to 24 V</p> <p>Power supply requirements: 24 V DC +10% / -20% current input ≤135 mA / ≤175 mA with camera, 150 mA with switched on spotlight Ripple: ≤ 200 mV</p> <p>Dimensions: Ø 65 x 220 mm (with connector attached)</p>	<p>Housing material: Stainless steel</p> <p>Mounting: External thread M 65 x 2 length 40 mm</p> <p>Weight: Approx. 0.9 kg</p> <p>Connection: with 8-pin connector</p> <p>Protection: IP 65 according to DIN 40050 (with connector attached)</p> <p>Adjustable parameters</p> <p>Analogue output 1 & 2: source/ scaling</p> <p>Digital input output 1 & 2: source/ switch point</p> <p>Transmission factor</p> <p>Compensation of background radiation</p> <p>Look-up table for temperature alignment</p> <p>Emissivity ϵ: 10 - 110 % increment size 0.1 %</p> <p>Smoothing function t_{98}: 0 - 999 sec</p> <p>Memory modes: - Min./Max. (peak picker) - Double maximum with adjustable hold time</p> <p>Optional accessories: calibration certificate according to ISO 9001 calibration certificate according to DKD large variety of mounting devices, digital displays, software, etc.</p>
---	---	---

32.1 Field of View Diagram for PA 38

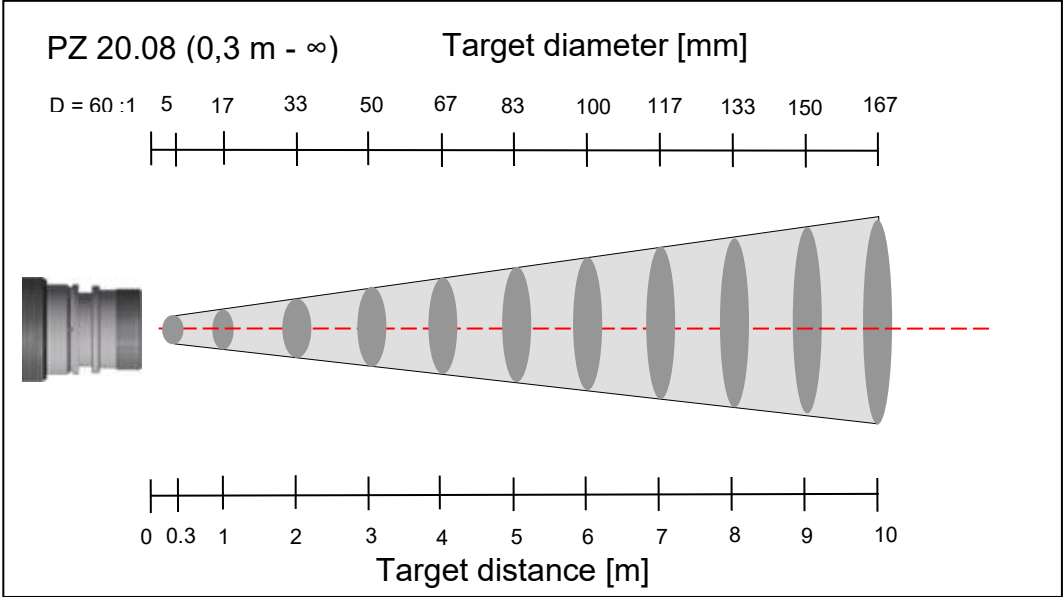

33 Dimensions

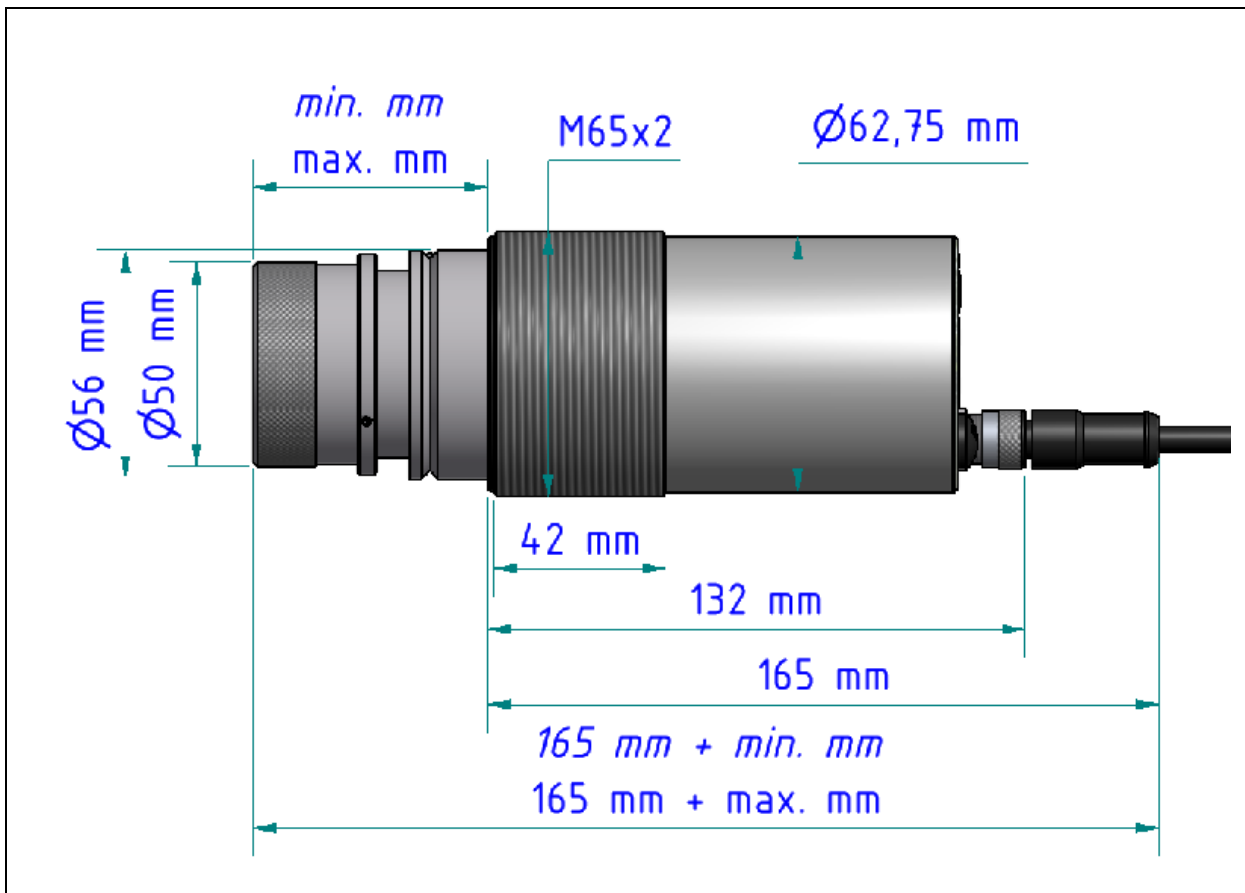

34 Technical data camera

- Video-System: Composite Video PAL, 1 Vpp, 75 Ohm
- Connection: Pyrometer -> TNC plug, monitor-> chinch or BNC (video cable VK 02/F), electrically isolated from the power supply of the pyrometer
- Resolution: 722 x 576 pixel
- Image overlay: target marker
- Target Brightness Control (TBC)

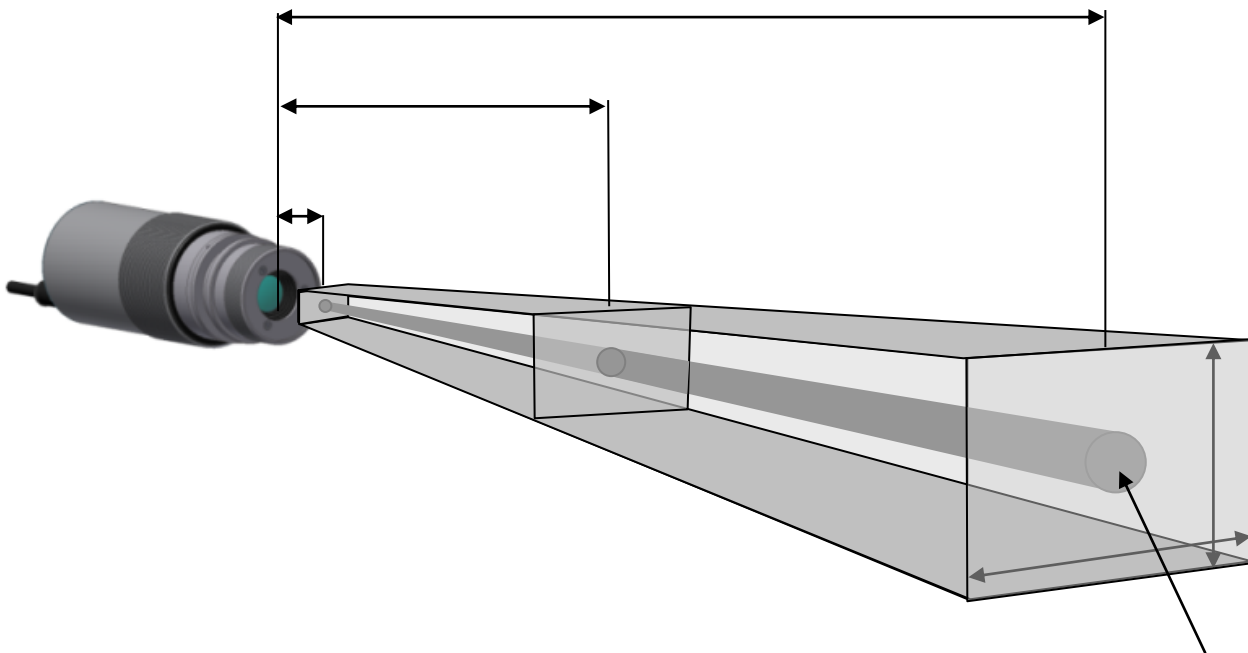

When connecting the video cable VK 02/F, make sure that the plug is tightened

Optic		Area target size [m]														
		0.2	0.3	0.4	1	1.2	2	3	4	5	6	7	8	9	10	
Standard 20.01	HFOV [mm]			16.2	44.9	54.4	92.7	140	188	236	284	332	379	427	475	
	VFOV [mm]			12.1	33.7	40.8	69.5	105	141	177	213	248	285	320	356	
Close-up 20.03	HFOV [mm]	8.5	14.1	19.8												
	VFOV [mm]	6.4	10.6	14.8												
Tele lens 20.06	HFOV [mm]					32.5	56.4	86.3	116	146	176	206	236	266	295	
	VFOV [mm]					24.4	42.3	64.7	87.1	110	132	154	177	199	222	
Wide angle 20.05	HFOV [mm]	41.7		79.4	192.6	230.3	381	570	759	947	1136	1324	1513	1702	1890	
	VFOV [mm]	31.3		59.6	144.4	172.7	286	427	569	710	852	993	1135	1276	1418	
Optic F50 20.08	HFOV [mm]		19.6	26.8	69.8	84.2	142	213	285	357	428	500	572	643	715	
	VFOV [mm]		14.7	20.1	52.4	63.1	106	160	214	267	321	375	429	482	536	

35 Transmission values of protective glasses

In the table you find the transmission values of the used protective glasses. In the column types you find the mechanical accessories in which the glasses are used.

Article number	Description	Transmission (reflexion) [%]						Used in followings types
		0.85 µm	1.4 µm	2 µm	3.9 µm	4.7 µm	8-14 µm	
1057687	Quartz protective glass	94	94	94				PA 20/C
1077319	Quartz protective glass	94	94	94				PZ 20/I AF 1 PZ 20/I AF 2 PZ 20/I AF 4
1008177	Quartz protective glass	94	94	94				PA 20/I
1023961	Sapphire protective glass	87	87	87	86	76		PS 15/I AF 1 PS 15/I AF 2
1021133	Sapphire protective glass	86	86	87	86	76		PA 15/I AF 1
1066877	Sapphire protective glass	86	86	87	86	76		PZ 15/I AF 2 PZ 15/I AF 3
1048531	Protective glass	92	91	90				PV 11
120314	Protective glass	93	92	90				Serie CellaTemp PA, PT, PZ
1048533	Protective glass	92	91	90				PZ 20/X AF 5
1045534	Protective glass	92	91	90				PZ 20/X AF 6
295757	Mirror	95	96	97				PS 11/W
1021132	ZnS protective glass						71	PA 10/I
515164	ZnS protective glass						71	PZ 20/I AF 3
1057688	ZnS protective glass						71	PA 10/C
119394	ZnS protective glass						71	PS 11/D PS 11/D AF 2 PS 11/S PS 11/N AF 3
515089	ZnS protective glass						71	PZ 10/I AF 1
515167	ZnS protective glass						71	PZ 10/A F 4



The specified transmission values are "typical values". When using the protective glass at the pyrometer, measurement deviations may occur. These may have to be corrected by the emissivity correction.

36 Accessories

Description	Product Name	Article No.
Cable length 5 m, 8 x 0.25 mm ² , shielded	VK 02/A	101 3909
Video cable	VK 02/F	101 1446
Polarising filter	PA 20/P	100 9974
Mounting bracket	PA 11/U	100 9679
Lock nut	KM 13	513 854
ZNS window	PA 10/I	1014893
Sapphire window	PA 15/I	1021055
Quartz window	PA 20/I	1008144
Mounting angle, adjustable	PA 11/K	100 7490
USB cable	VK 11/D	100 9677

36.1 Mounting angle PA 11/K

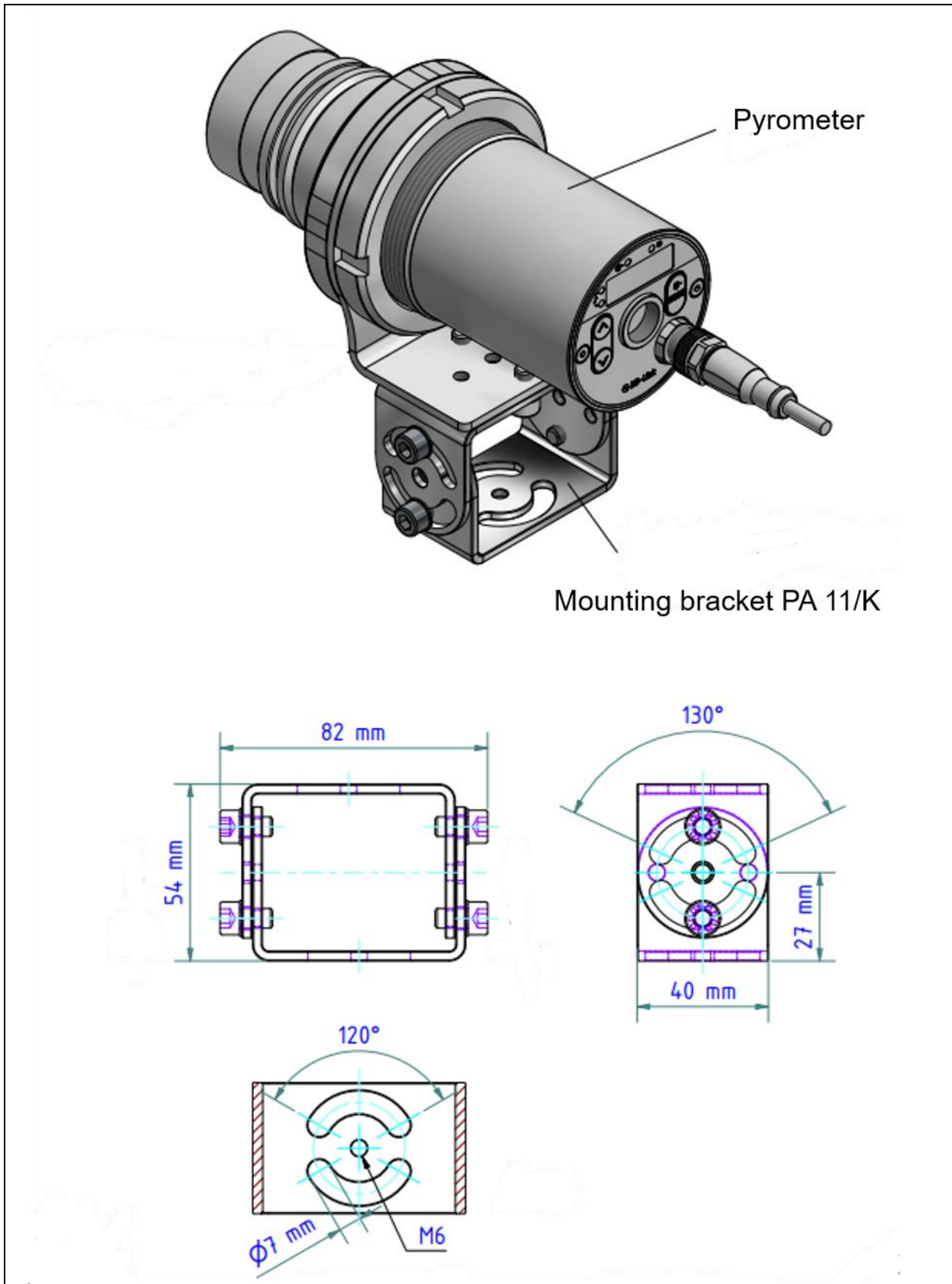

36.2 Polarising filter PA 20/P

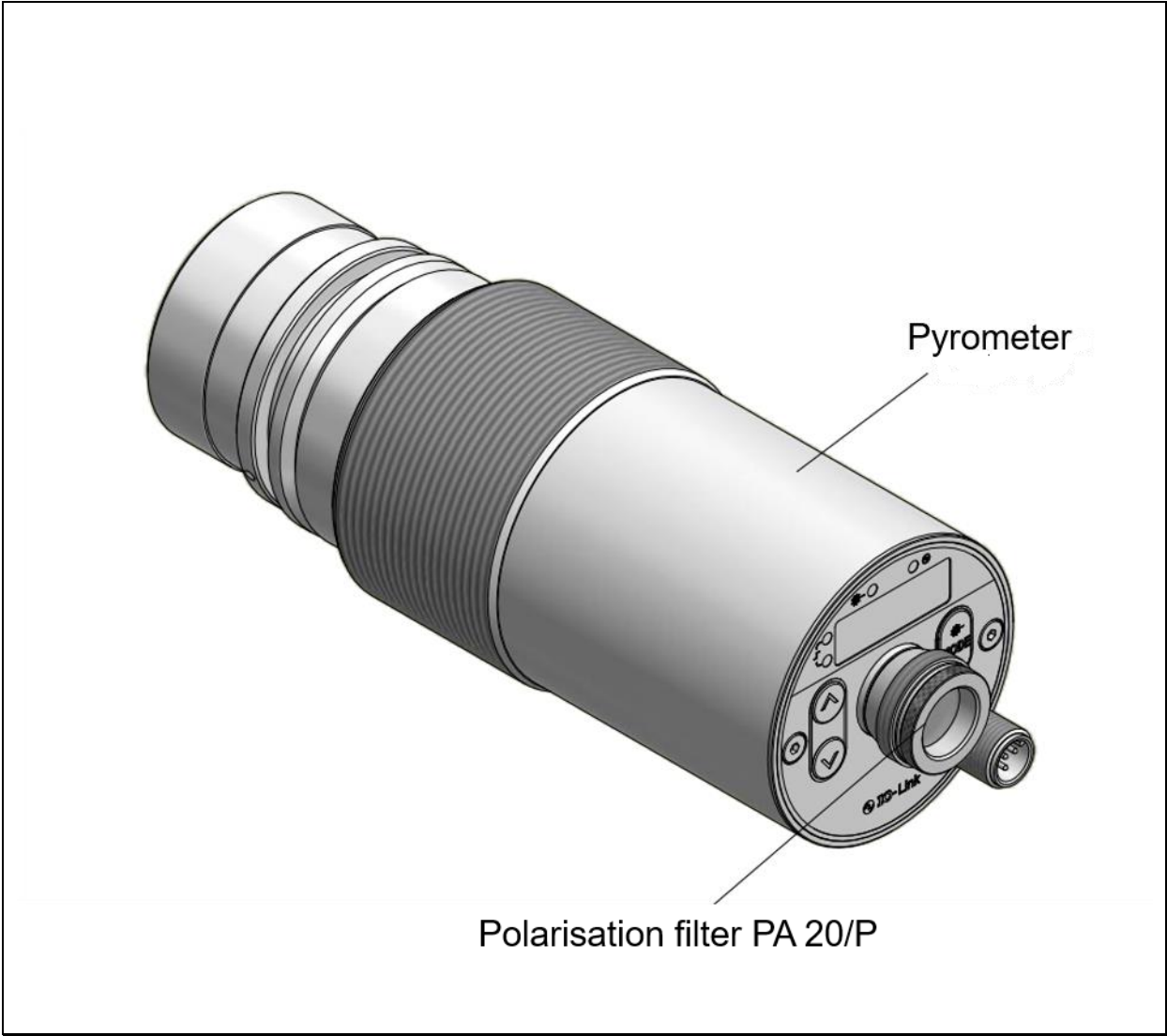

36.3 Mounting bracket PA 11/U

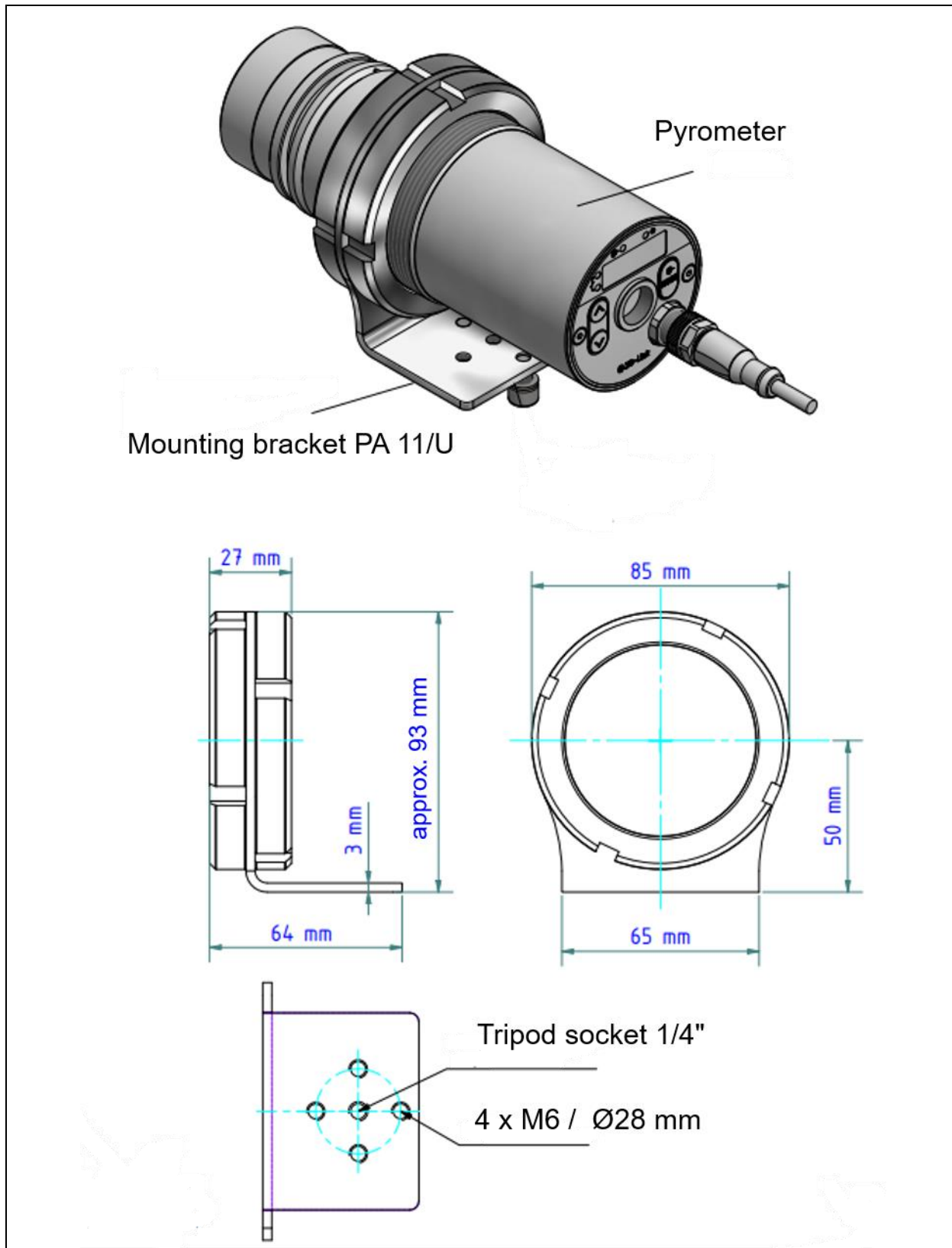

36.4 ZnS Window PA 10/I

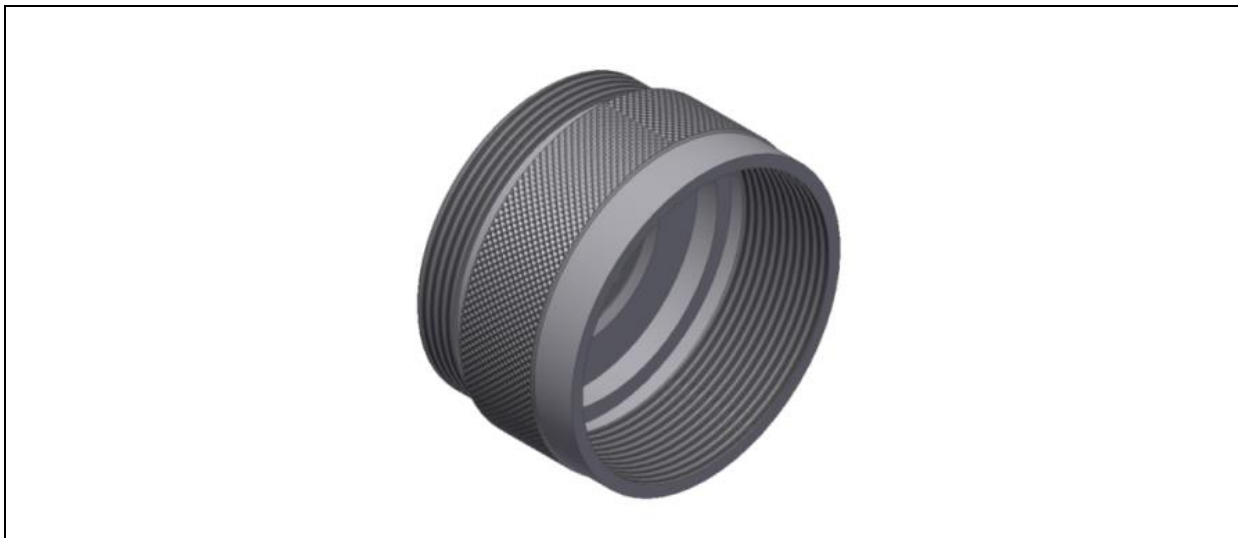

For pyrometer PA 10

36.5 Quartz window PA 20/I and sapphire window PA 15/I

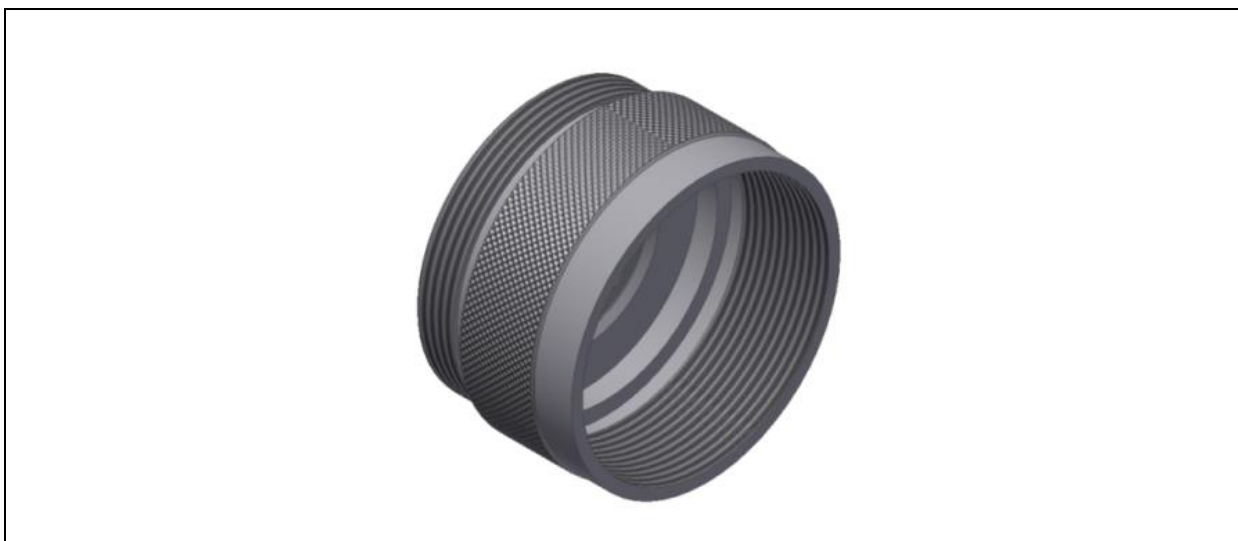

Quartz window for pyrometer PA 2x, PA 3x

Sapphire window for pyrometer PA 13, PA 15, PA 17 and PA 18

⚠ Attention

The replacement of the protection glass can be performed only by authorized person. When removing the protective screen, always wear protective glasses and -gloves.

36.6 Cable VK 02/A

Ident. - Nr. 101 3909

Belegung <i>Configuration</i>	Pol <i>contacts</i>
weiß <i>white</i>	an 1 <i>at 1</i>
braun <i>brown</i>	an 2 <i>at 2</i>
grün <i>green</i>	an 3 <i>at 3</i>
gelb <i>yellow</i>	an 4 <i>at 4</i>
grau <i>grey</i>	an 5 <i>at 5</i>
rosa <i>pink</i>	an 6 <i>at 6</i>
blau <i>blue</i>	an 7 <i>at 7</i>
rot <i>red</i>	an 8 <i>at 8</i>

Schirm durchgängig an Verschraubung
Shield constantly at screw connection

8 polig
8 poles

Anschlussquerschnitt 0,25mm² (AWG 24)
Schutzart IP68 / IP67 geschirmt
Obere Grenztemperatur + 85°C
Untere Grenztemperatur - 25°C

*Wire gauge 0,25mm² (AWG 24)
Degree of protection IP68 / IP67 shielded
Upper temperature + 85°C
Lower temperature - 25°C*

(Maßstab 3:1)

36.7 Cable VK 02/F

Ident. - Nr. 103 1446

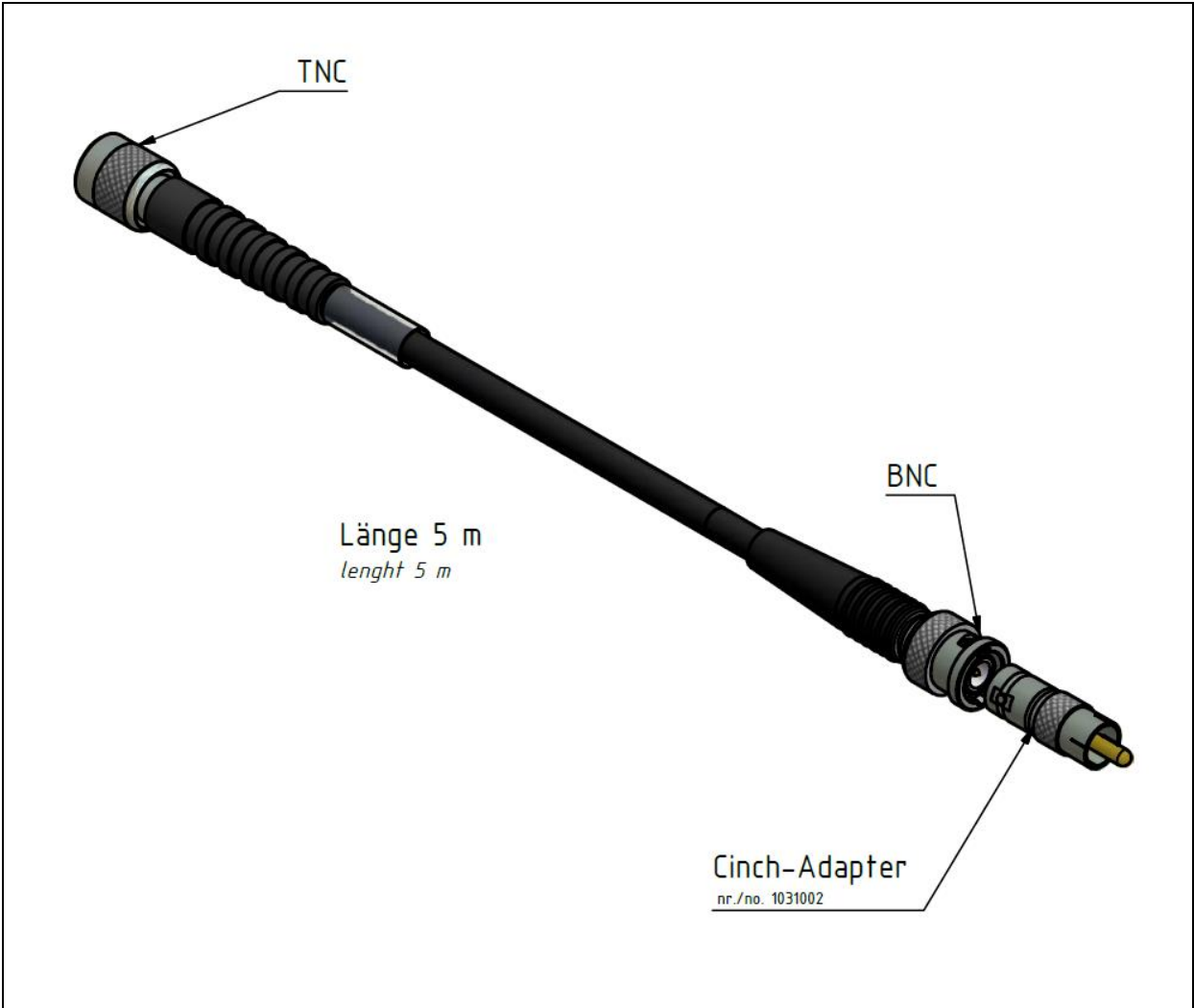

37 Mounting combinations

37.1 Mounting combination PA 20-007

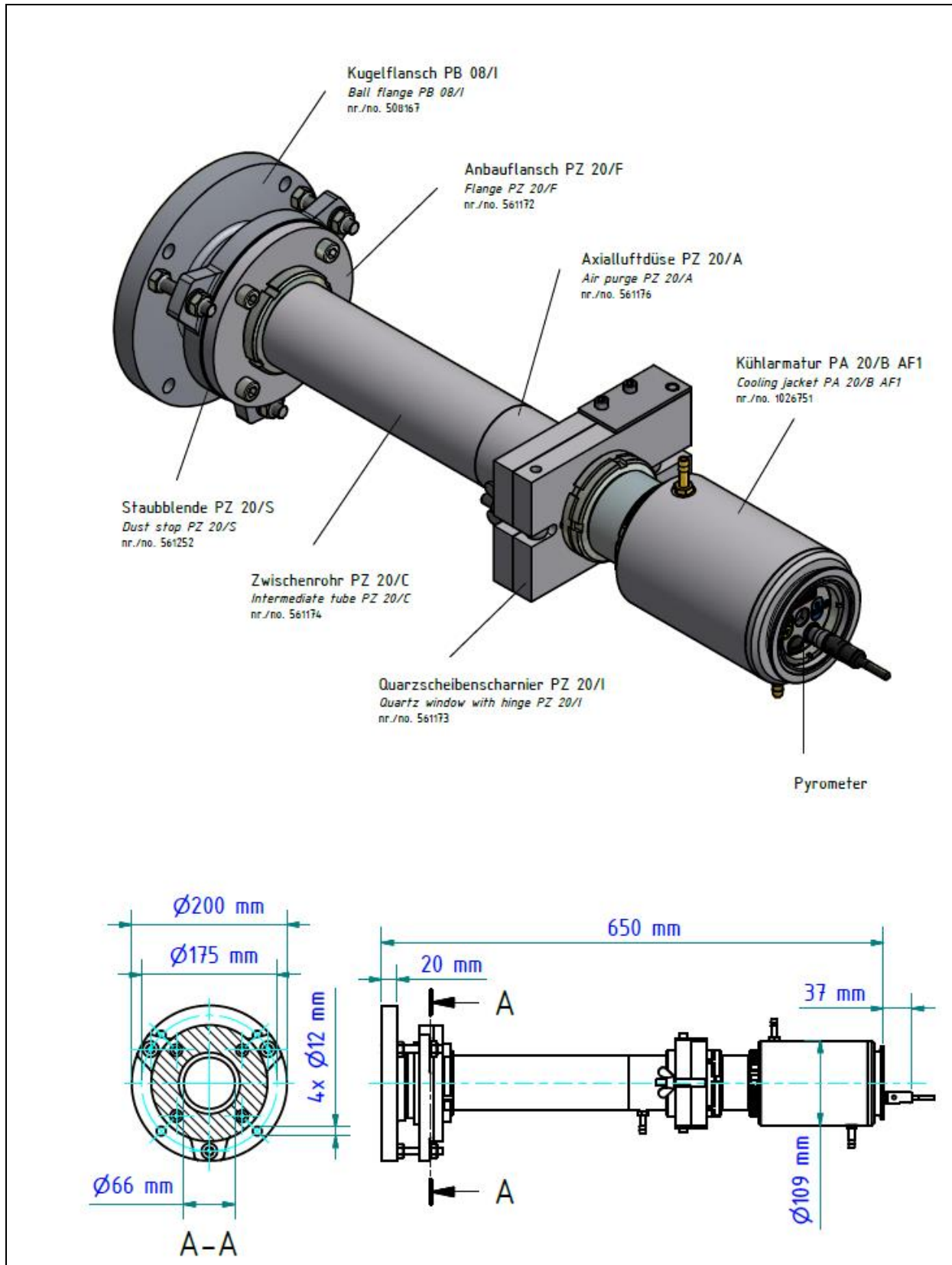

37.2 Mounting combination PA 20-010

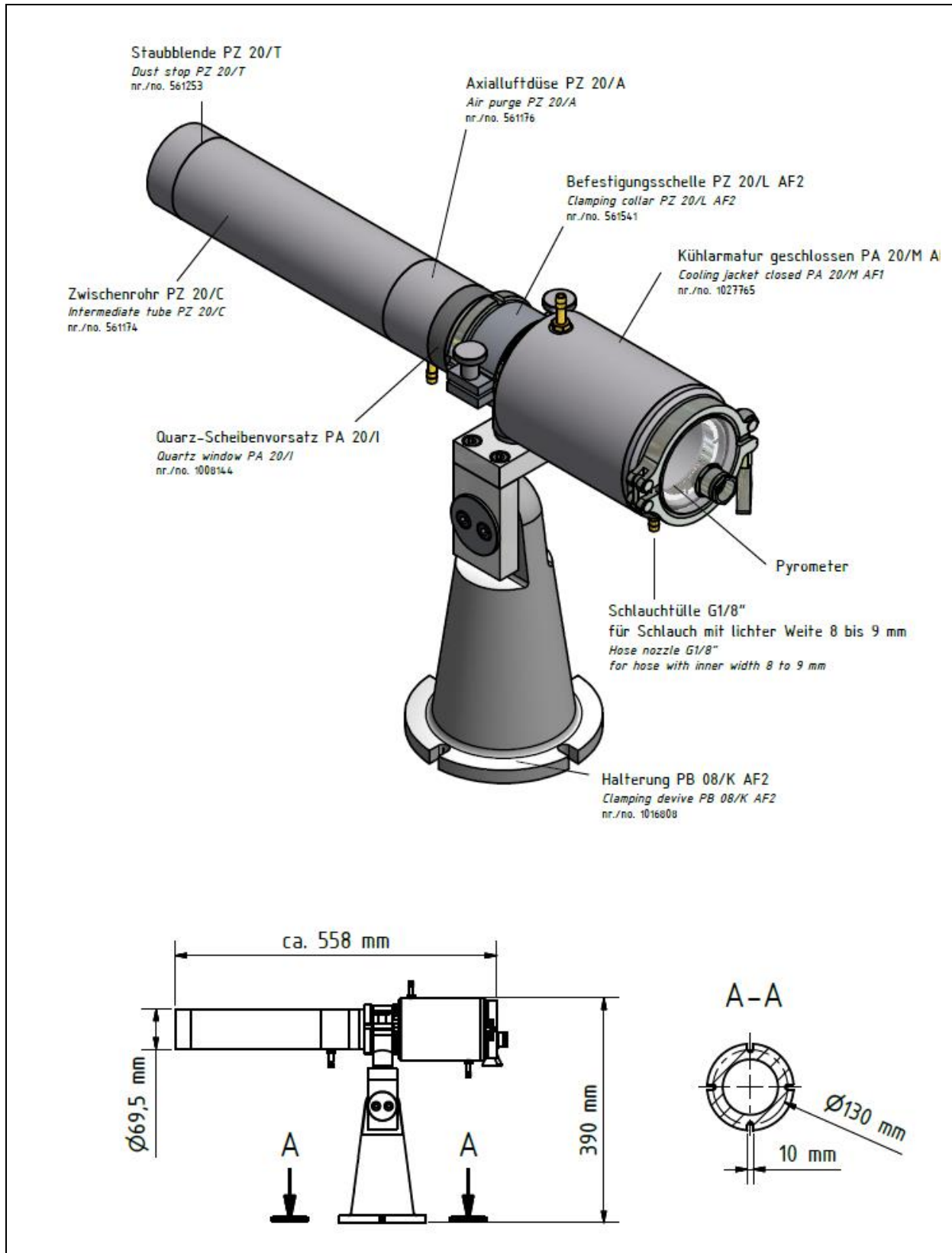

38 Glossary

Auto print	After connecting the power supply, the pyrometer automatically begins transmitting measurement data via the serial interface.
Print cycle time	The cycle time for the temperature data output via the serial interface.
Distance to target size ratio	Describes the ratio between the pyrometer-to-object distance and the target spot diameter.
Double Max-Memory	Brief temperature peaks will be held for an adjustable holding time.
Emissivity	A measure of a material's ability to emit energy by radiation. The emissivity value is the ratio of energy radiated by a particular material's surface to energy emitted by an ideal radiator (black body) at the same temperature. A pyrometer's emissivity setting must be adjusted for the specific material to be measured.
Switching outputs	The digital outputs can be used as digital inputs
Two-colour pyrometer	Detects infrared radiation at two different wavelengths at the same time. Based on that ratio, the pyrometer calculates the temperature value.
Spectral pyrometer	Detects infrared radiation at one particular wavelength and produces a temperature reading from that measurement.

39 Shipping, Packaging and Disposal

39.1 Inspecting your shipment

Unpack and inspect the entire shipment immediately upon receipt to make sure it is complete and undamaged.

If the container/package shows visible signs of damage, please refuse the shipment. If this is not possible, accept the shipment on the condition that the freight carrier's delivery record is noted with the extent of the damage to file a claim.

Should you discover a concealed loss or damage, report it to KELLER HCW and to the freight carrier immediately. If the period for filing claims has expired, you will no longer be able to make any claims for compensation of damage or loss.

39.2 Packaging

The packages used by KELLER HCW are made of carefully selected, environmentally compatible materials and are thus recyclable. We suggest you retain the packaging for possible future use; otherwise please ensure that they are disposed of in an ecologically sound manner.

39.3 Disposal of used apparatus

Used electrical and electronic equipment often contain valuable components. The owner/user may either return such an instrument to the manufacturer for disposal, or he must dispose of it himself in a professional and non-polluting manner.

KELLER HCW will not be held accountable for any inappropriate disposal carried out by the user/owner of KELLER HCW instruments.



40 Copyright

Portions of avr-libc are Copyright (c) 1999-2007

Keith Gudger,
Bjoern Haase,
Steinar Haugen,
Peter Jansen,
Reinhard Jessich,
Magnus Johansson,
Artur Lipowski,
Marek Michalkiewicz,
Colin O'Flynn,
Bob Paddock,
Reiner Patommel,
Michael Rickman,
Theodore A. Roth,
Juergen Schilling,
Philip Soeberg,
Anatoly Sokolov,
Nils Kristian Strom,
Michael Stumpf,
Stefan Swanepoel,
Eric B. Weddington,
Joerg Wunsch,
Dmitry Xmelkov,
The Regents of the University of California.
All rights reserved.

Redistribution and use in source and binary forms, with or without modification, are permitted provided that the following conditions are met:

- * Redistributions of source code must retain the above copyright notice, this list of conditions and the following disclaimer.
- * Redistributions in binary form must reproduce the above copyright notice, this list of conditions and the following disclaimer in the documentation and/or other materials provided with the distribution.
- * Neither the name of the copyright holders nor the names of contributors may be used to endorse or promote products derived from this software without specific prior written permission.

THIS SOFTWARE IS PROVIDED BY THE COPYRIGHT HOLDERS AND CONTRIBUTORS "AS IS" AND ANY EXPRESS OR IMPLIED WARRANTIES, INCLUDING, BUT NOT LIMITED TO, THE IMPLIED WARRANTIES OF MERCHANTABILITY AND FITNESS FOR A PARTICULAR PURPOSE ARE DISCLAIMED. IN NO EVENT SHALL THE COPYRIGHT OWNER OR CONTRIBUTORS BE LIABLE FOR ANY DIRECT, INDIRECT, INCIDENTAL, SPECIAL, EXEMPLARY, OR CONSEQUENTIAL DAMAGES (INCLUDING, BUT NOT LIMITED TO, PROCUREMENT OF SUBSTITUTE GOODS OR SERVICES; LOSS OF USE, DATA, OR PROFITS; OR BUSINESS INTERRUPTION) HOWEVER CAUSED AND ON ANY THEORY OF LIABILITY, WHETHER IN CONTRACT, STRICT LIABILITY, OR TORT (INCLUDING NEGLIGENCE OR OTHERWISE) ARISING IN ANY WAY OUT OF THE USE OF THIS SOFTWARE, EVEN IF ADVISED OF THE POSSIBILITY OF SUCH DAMAGE.

41 Default settings

41.1 Temperature measurement via spectral channel

(configuration layer: `c 00 !`)

Parameter	Function	Default	User settings
<code>EPS.1</code>	Emissivity factor L1	99.0%, 99 %*	
<code>TRU.1</code>	Transmission factor L1	100 %	
<code>bAc.1</code>	Ambient temperature compensation	Off	
<code>bAc.t</code>	Temperature of ambient source of radiation	Off	
<code>bAc.!</code>	Influence of ambient IR radiation	--	
<code>L.in.1</code>	Temperature offset using linear interpolation	Off	
<code>L.H.1</code>	node x 1.-.10	--	
<code>L.Y.1</code>	node y 1.-.10	--	
<code>F.L.1</code>	Smoothing filter	Off, Automatic*	
<code>F.L.t</code>	Smoothing time	0.1 s	
<code>NE.N.1</code>	Min/Max memory	Off	
<code>NE.N.t</code>	Hold time for Min/Max	--	
<code>F.L.N</code>	Smoothing filter for min/max *	--	
<code>F.L.t</code>	Smoothing time*	--	
<code>cLr.N</code>	external delete for Min/Max memory*	--	
<code>t.dEL</code>	time delay**	--	
<code>tAct</code>	meas. time active**	--	
<code>t.d.S</code>	cut-off interval**	--	
<code>t.oUt</code>	timeout**	--	
<code>L.1</code>	Limit 1**	--	
<code>L.2</code>	Limit 2**	--	
<code>F-Pr</code>	Average weighting**	--	
<code>tSP₋</code>	Threshold plausibility**	--	
<code>tSP⁻</code>	Threshold plausibility**	--	
<code>ARno</code>	Mode of display**	--	
<code>ARSt</code>	Autoreset**	--	
<code>ch.L.2</code>	Set Li2 check on tAct**	--	
<code>SAvE</code>	Save	--	
<code>ESc</code>	Escape	--	

* Pyrometer PA 10 AFxx;

** Only available with ATD function

41.2 Configuration I/O

(configuration layer: $\epsilon \text{ O } \text{IO}$)

Parameter	Function	Default	User settings
Ao1S	Ao1 select source	Lamda 1	
Ao1L	Ao1 define lower limit of temp. span	Measuring range begin	
Ao1H	Ao1 define upper limit of temp. span	Measuring range end	
Ao14	Ao1 0/4 - 20mA	4 – 20 mA	
Ao2	Analogue output 2	Off	
Ao2S	Ao2 select source	--	
Ao2L	Ao2 define lower limit of temp. span	--	
Ao2H	Ao2 define upper limit of temp. span	--	
Ao24	Ao2 - 0 / 4 - 20mA	--	
do1	Switching output 1	On	
do1S	Do1 select source	Status Ready signal	
do1F	Do1 function	Level/signal	
do1t	Do 1 switching threshold	--	
do1h	Do1 signal threshold	--	
do1L	Do1 lower limit of range	--	
do1H	Do1 upper limit of range	--	
do1L	Do1 delay time	0.00 s	
do1H	Do1 Hold time	0.00 s	
do2	Switching output 2	Off	
do2S	Do2 select source	--	
do2F	Do2 function	--	
do2t	Do 2 switching threshold	--	
do2h	Do2 signal threshold	--	
do2L	Do2 lower limit of range	--	
do2H	Do2 upper limit of range	--	
do2L	Do2 delay time	--	
do2H	Do2 Hold time	--	
AIFn	Analogue input function	--	
A.U1	Analogue in upper and lower voltage values	--	
A.U2	Analogue in upper and lower input variables	--	
A.V1	Analogue in upper and lower input variables	--	
A.V2	Analogue in upper and lower input variables	--	
SAVE	Save		
ESC	Escape		

41.3 General Functions

(configuration layer: `c 0 ! !`)

Parameter	Function	Default	User settings
<code>LEd6</code>	Green status LED	DO1	
<code>P.la.</code>	Activate laser*	INT	
<code>P.l.t</code>	Laser ON-time	2 min	
<code>tErn.</code>	Assign Interface	USB	
<code>A.Ste.</code>	Automatic temperature data output	Off	
<code>A.cyc.</code>	Cycle for automatic temp. data output	0.1 s	
<code>Addr.</code>	Device address	001	
<code>d.SP.</code>	Display panel	active	
<code>Unit</code>	temperature scale	Celsius	
<code>c.oul.</code>	Screen insert temperature reading**	on	
<code>c.tb.c.</code>	TBC exposure metering**	"on" spot weighted	
<code>c.col.</code>	White balance**	"DAYL." daylight	
<code>SAvE</code>	Save		
<code>ESc</code>	Escape		

* Only available at pyrometer with laser target spot indicator

** Only available at pyrometer camera

