



Pyrometer *CellaCast PX 8x*

Content

1	General	5
1.1	Information about the manual	5
1.2	Explanation of the symbols	5
1.3	Liability and Warranty.....	5
1.4	Copyright.....	6
2	Safety.....	6
2.1	Intended use	6
2.2	User's responsibility.....	6
2.3	Safety requirements.....	6
2.4	Laser Radiation Hazard	7
3	Shipping, packaging and disposal	8
3.1	Inspection after shipping.....	8
3.2	Packaging	8
3.3	Disposal of the old devices	8
4	Theory of Non-Contact Temperature Measurements.....	9
4.1	Advantages of Non-Contact Temperature Measurement	9
4.2	Measurements at Black Bodies (Cavity Radiators).....	9
5	Function	10
6	Installation.....	11
6.1	Selecting an installation location.....	11
6.2	Mechanical installation	11
6.3	Assembly fibre optic cable	12
7	Electrical connection	13
8	Focussing	14
9	Parameters to be set for commissioning	16
9.1	Setting the sampling time at the PX 83.....	17
9.2	Setting the sampling time at the PX 80/81.....	18
10	Adaptation of temperature level	20
11	Shielding and Grounding	21
12	Operating control and display	22
12.1	Processing of measuring signals	23
12.2	Analogue output.....	23

12.3	Switching threshold OUT 1	24
12.4	Output signal	24
12.5	Switch on delay	24
12.6	Switch off delay	24
12.7	Hysteresis function	25
12.8	Window function	26
12.9	Switching output OUT 2	27
12.10	Dirt alert	27
12.11	Damping function	28
12.12	Peak hold function	28
12.13	ATD function	29
12.14	IO-Link	33
13	Menu	33
13.1	Analogouge output Ao	33
13.2	Switching output OUT 1	34
13.3	Switching output OUT 2	35
13.4	Two-colour channel	36
13.5	Spectral channel Lambda 1	37
13.6	Spectral channel Lambda 2	38
13.7	Advanced Features	39
14	Menu explanation	40
14.1	Analogue output	40
14.2	OUT 1 (d1)	40
14.3	OUT 2 (d2)	41
14.4	Two-colour channel (9u)	42
14.5	Spectral channel (L 1) (L 2)	44
14.6	Advanced Features (EF)	46
15	Parameterizing	47
15.1	Setting parameters – general information	47
16	Error indications	48
17	Service functions	49
17.1	Reset all parameters to factory settings	49
17.2	Simulate a desired temperature	49
18	Maintenace	50
18.1	Cleaning the pyrometer lens	50
18.2	Replacing the protective screen	50

19	Trouble shooting	51
19.1	No measured values are determined	51
20	Models	52
21	Field of view	52
22	General technical data	54
23	Device-specific technical data	56
24	Field of view camera	59
25	Accessories	60
26	Default settings	60
27	Copyright	60

1 General

1.1 Information about the manual

The purpose of the Operating Manual is to provide the user with all necessary information to be able to install the pyrometer and any necessary accessories. Before starting installation, be sure to read and understand this entire manual, in particular the chapter on safety! The instructions contained in this manual, especially those concerning safety, as well as site specific regulations governing UV radiation must be complied with at all times. It is imperative to comply with the safety instructions and the accident protection regulations valid for the area of application!

1.2 Explanation of the symbols

Important safety-related references in this manual are marked with a symbol.

ATTENTION

This symbol points out guidelines. If you do not observe them, the device might be damaged, malfunctioning or even fail to operate.



CAUTION

This symbol points out guidelines which should be followed for efficient and trouble-free operation.

- ▶ Action
This symbol instructs the operator to take action.
- > Reaction, result
This symbol indicates the result of the action taken.

1.3 Liability and Warranty

All information compiled in this manual is in accordance with applicable regulations. The statements made are based on state-of-the-art technology and reflect our extensive knowledge and many years of experience.



Always carefully read this Operating Manual before beginning any work on or with the instrument, especially prior to installation and initial setup! The Manufacturer shall not be held liable for any damages or malfunctions arising from a disregard of the warnings and instructions contained herein.

1.4 Copyright

This Operating Manual should be treated as confidential. It is solely intended for the use by persons involved with the instrument. This manual may not be made available to a third party without prior Manufacturer's consent. Please contact the Manufacturer if the need should arise.

2 Safety

This chapter outlines all important safety aspects to be considered for optimum employee protection and to ensure safe and reliable operations.

2.1 Intended use

The pyrometer is solely intended for use as described in this manual. Operational safety can only be ensured when the instrument is used for its intended purpose.



The use of the pyrometer for any other purpose beyond what is specified in this manual is prohibited. Using the instrument in any other manner will be considered as improper.

The manufacturer is only liable for damage that occurs during correct use. The prerequisite for any liability, however, is that the cause of the damage is due to a defective product and the defect in the product was caused by the manufacturer.

2.2 User's responsibility

The pyrometer may only be used when it is in perfect working condition.

2.3 Safety requirements

The instrument operates at low voltage (18 – 34 V DC). The power supply unit must conform to directive EN 50178, SELV, PELV.

2.4 Laser Radiation Hazard

Laser radiation can be harmful to the eye!

The CellaCast PX with laser operates with a class 2 red light laser. Direct prolonged viewing of a laser beam can injure the retina. Therefore, the following safety precautions must be strictly observed, otherwise the laser may not be operated!

- Only use the laser to align and focus the pyrometer. Deactivate the laser immediately afterwards. Alternatively, the laser will automatically switch off after 2 minutes.
- Never look directly into the laser beam path
- Do not leave the instrument unattended when the laser is activated.
- Do not point the laser beam at any person
- During pyrometer installation and alignment, make sure to avoid the possibility of laser reflections caused by reflective surfaces.
- All currently valid laser safety standards must be observed.

Laser power

The laser operates at a wavelength of 630 - 680 nm (visible red light). The emitted power of the laser beam at the lens opening is max. 1.0 mW. Under normal operating conditions, the emitted radiation does not present a danger to human skin. This laser product is classified according to laser class 2, EN60825-1, IEC60825-1.

Laser Warning Label

The black and yellow laser warning label is affixed next to nameplate of the instrument. An arrow indicates the laser emission path (lens opening).





If the pyrometer is installed within, a machine or equipment in such a way that the instrument's warning label is visibly blocked, additional laser warning labels (not included in scope of delivery) must be affixed to the equipment or accessory in immediate vicinity to the laser beam emission path opening.

3 Shipping, packaging and disposal

3.1 Inspection after shipping

Unpack and inspect the entire shipment immediately upon receipt to make sure it is complete and undamaged. If the container/package shows visible signs of damage, please refuse the shipment. If this is not possible, accept the shipment on the condition that the freight carrier's delivery record is noted with the extent of the damage in order to file a claim. Should you discover a concealed loss or damage, report it to the shipper or freight carrier immediately. If the period for filing claims has expired, you will no longer be able to make any claims for compensation of damage or loss.

3.2 Packaging

The packages used are made of carefully selected, environmentally compatible materials and are thus recyclable. Please ensure that they are disposed of in an ecologically sound manner.

3.3 Disposal of the old devices

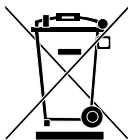

Old electrical and electronic devices frequently still contain valuable materials. These devices can be returned for disposal to the manufacturer or they must be disposed properly by the user.

For the improper disposal of the device by the user, the company KELLER HCW is not responsible.

4 Theory of Non-Contact Temperature Measurements

All materials radiate thermal energy in all states of aggregation above absolute zero. This radiation is mainly caused by atomic or molecular oscillations.

This temperature radiation is only a limited sector within the total electromagnetic radiation spectrum. It extends from the visible range starting at wavelengths of approx. 0.5 μm to the infrared range with wavelengths of more than 40 μm . Radiation pyrometers detect infrared radiation for non-contact temperature measurement.

4.1 Advantages of Non-Contact Temperature Measurement

- Non-contact temperature detection means cost-effective temperature measurement because this technique only requires a single investment in an instrument without any follow-up costs for consumables such as thermocouples
- This method enables temperature detection of moving objects - quick temperature measurements within milliseconds - for example at automatic welding processes
- Small objects with medium and high temperatures can also be easily and accurately measured
- When measuring materials with low specific heat, a non-contact method does not induce heat loss which would distort the temperature reading (as is the case with contact temperature probes). Non-contact temperature detection is ideal with corrosive molten materials for which the use of thermocouples is hardly feasible
- Last but not least it is also possible to measure the temperature of voltage-carrying objects.

4.2 Measurements at Black Bodies (Cavity Radiators)

A black body or a black radiator is used to calibrate radiation pyrometers. This black body is designed in a way that its radiation does not depend on material characteristics, but only on its temperature. A black body emits at any wavelength the maximum energy possible for the specific temperature. Real bodies do not have this ability. In other words, a black body completely absorbs the radiation without reflection or transmission losses. The spectral emissivity coefficient $\epsilon(\lambda)$ of a black body is equal to 1 or 100 %.

The emissivity coefficient indicates the ratio of radiation of a real body (target) to the radiation of an ideal black body (target) to the radiation of an ideal black body.

$$\varepsilon(\lambda) = \frac{M}{M_S}$$

$\varepsilon(\lambda)$: Emissivity coefficient of the object's surface (targeted spot) at wavelength λ

M: Emissivity coefficient of the object's surface (targeted spot) at wavelength

M_S: radiant energy emitted by a black body (perfect radiator)

Most burning, annealing and hardening furnaces emit a radiation of nearly ,1' which corresponds to the conditions of a black body if the aperture through which the measurement is made is relatively small.

5 Function

The pyrometer detects the radiated infrared radiation of objects without contact and converts them into an electrical switching signal and an analogue output signal.

6 Installation

6.1 Selecting an installation location

When choosing the installation location and during the pyrometer alignment, it is imperative to ensure that only the free pouring stream is within the field of view.

When the background is hotter than the object focused on or when the measurement is made through the inoculant, the accuracy of measurement will be influenced.

The pyrometer should be oriented as far as possible at right angles to the pouring stream. Ideally, the pyrometer should be mounted so that it is aligned with the back of the pouring stream.

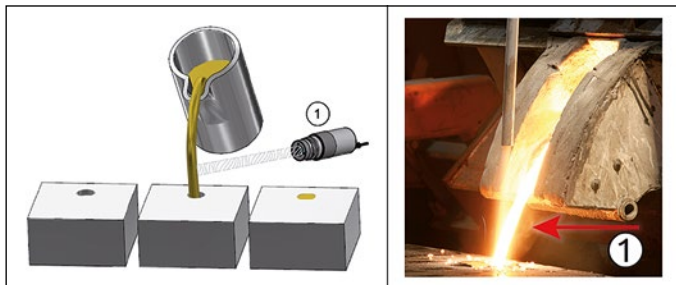

1: Ideal measuring point

6.2 Mechanical installation

The distance should be adjusted in that way, that the pouring stream is wide enough to fill up at least 30 % of the measurement area. Reduce the distance, if the pouring stream covers less than 30 % of the measurement area. When aiming the pyrometer, make sure that the pouring stream is in the centre of the measurement area. During pouring it must be ensured that the pouring stream is always within the measuring field, even if the pouring stream is fluctuating.

In order to prevent the pyrometer optics from contamination, connect the scavenging air. Approx. 50 l/min with a maximum pressure of 6 bars are required for that. Use oil-free and dirt-free compressed air.

If the expected ambient temperatures are $> 65\text{ }^{\circ}\text{C}$, a cooling system is required.

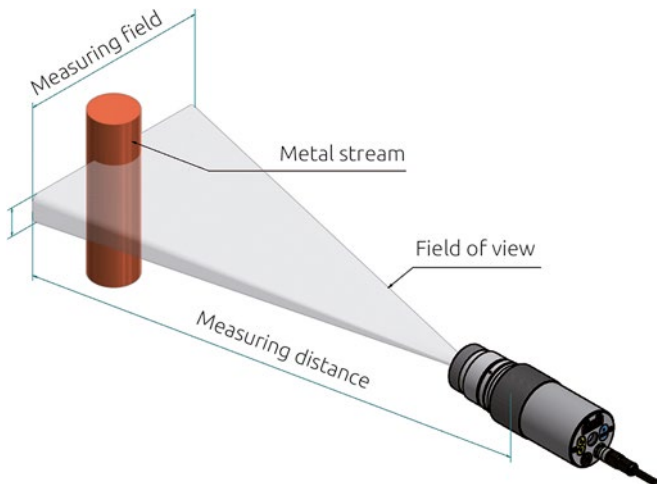

6.3 Assembly fibre optic cable

One end of the optical fibre has a nameplate showing the serial number of the corresponding basic pyrometer. This is the end which must be screwed onto the pyrometer. For proper connection, the arrow on the nameplate of the fibre optic cable and the arrow on the pyrometer should point toward each other. The serial number of the measuring head should also correspond to the pyrometer.

⚠ ATTENTION

The fibre optic cable must not be exposed to tensile load and must not be twisted. The minimum bending radius is 125 mm.

7 Electrical connection

The pyrometer is supplied with low voltage 24 DC (18 ... 32 V DC).

⚠ ATTENTION

The device may only be installed by a skilled, qualified electrician. Do not connect it while the voltage supply source is turned on. Please observe international safety regulations at all times.

- ▶ Disconnect the pyrometer from any voltage source.
- ▶ Connect the pyrometer according to the following schematic.

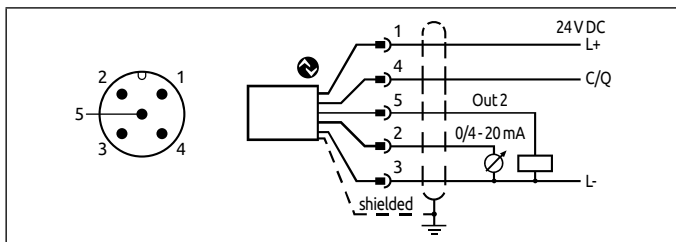

Pin 1	BN (brown)	L+ (Power supply 24V DC)
Pin 4	BK (black)	Open Collector switching output; $I_{\max} = 150 \text{ mA}$ or IO-Link OUT 1
Pin 5	GY (grey)	Open Collector switching output; $I_{\max} = 150 \text{ m}$ OUT2
Pin 2	WH (white)	Analogue output; 0/4 ... 20mA
Pin 3	BU (blue)	L- (GND)



The pyrometer must be protected against electromagnetic fields. Therefore, use a shielded cable, connecting it via connector casing of the pyrometer to the housing.



Use a flyback diode when switching inductive loads.

8 Focussing

If the pyrometer is mounted in a cooling or protective housing, remove the pyrometer from the protective fitting. For easier focusing, hold the pyrometer parallel to the cooling or protective fitting.

Pyrometer with through-lens sighting

When aiming the pyrometer with through-the-lens sighting to a target, both the targeted object and the target marker (distinctly marked circled or rectangle spot in the viewfinder) must appear in sharp focus simultaneously.

Pyrometer with camera

The models PX xx AF xx /C features an integrated camera. When aiming the pyrometer focus the sensing head until the video images is sharp.

Pyrometer with laser sighting

The pyrometer models PX xx AF xx /L feature a laser spot light which can be activated to facilitate instrument alignment to the target spot. To activate the laser, press the MODE button on the rear panel for 2 seconds. Alternatively, the laser can be switched on with the IO-Link interface.

To focus, rotate the optics until the pilot light is projected as a sharp, round light spot on the object to be measured.

Pyrometer with fibre optic

The pyrometers have a laser that can be activated to align the sensing head to the target spot. To activate the laser, press the MODE button in the rear panel for 2 seconds. Alternatively, the laser can be switched on via the IO-Link interface

For focal adjustment loosen the shown socket screw (hexagon socket screw DIN 916) with a wrench (DIN 911) and shift the internal body of the tube towards the lens tube. Due to the O-ring sealing between the internal body of the tube and the lens tube the focal adjustment must be carried out very slowly so that the air pressure in the space between lens and internal body of the tube can be equalised.

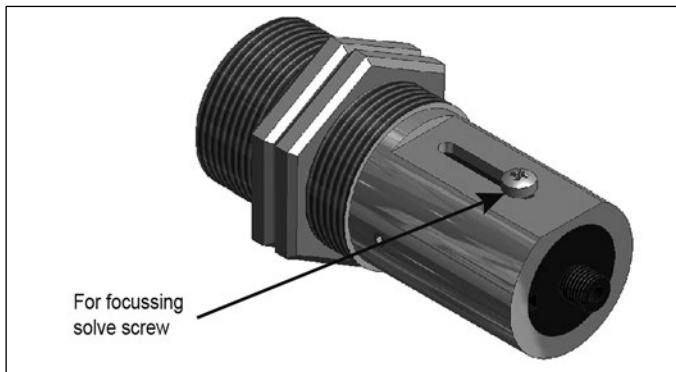

EN



The activated laser pilot light can influence the measured temperature. This influence will vary, depending on the instrument model and the temperature.

To protect the laser against overload, an over temperature is provided. At temperatures above 60 °C, the laser switches of an can no longer be activated. To check, whether the laser is activated, the parameter LED lights up.

In normal operation, the laser is switch off. After activation, the laser switch of again after 2 – 15 minutes. The operator must be familiar with the pyrometer and above safety guidelines.



If focusing is not possible during installation, focusing can also be done outside the plant. To do this, set the pyrometer to the same distance as the distance between the pyrometer and the pouring stream.

9 Parameters to be set for commissioning

On delivery the pyrometer is parameterized for the measurement on liquid metals.

The start of a measuring cycle is automatically detected and depends on limit 1, limit 2 and the dead time. Before starting the measurement, Limit 1 must have fallen below at least once. Limit 2 must be exceeded continuously for the duration of the dead time (T.DEL). If necessary, the limits are to be adapted.

Two-colour channel [90] → ATD function [99 & d]

Parameter	Function	Default
[L1 . 1]	Limit 1	1100 °C
[L1 . 2]	Limit 2	1200 °C

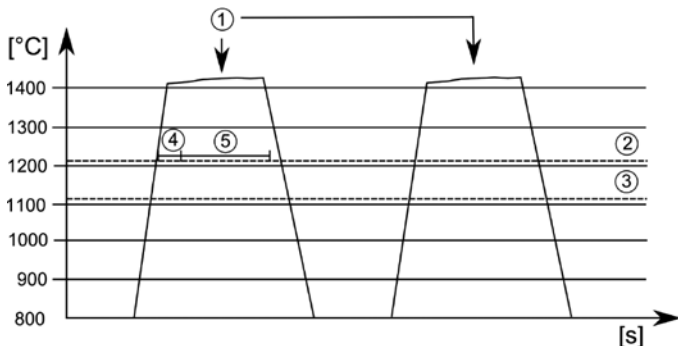

- 1: Measuring object in front of the pyrometer
- 2: Limit 2 [L1 . 2]
- 3: Limit 1 [L1 . 1]
- 4: Time delay [t.d.E.L.]
- 5: Sampling time [t.R.C.t.]

9.1 Setting the sampling time at the PX 83

On delivery the pyrometer is parameterized on a discontinuous pouring stream. If the pouring times are < 5 seconds the measuring time needs to be adapted. The time delay (time after detection of the pouring stream up to the start of the measurement) and the measurement time must be less than the minimum pouring time.

Two-colour channel [90] → ATD function [99t d]

Parameter	Function	Default
t.d.E.L	Time delay [s]	1 s
t.R.C.t	Sampling time [s]	Auto

- ▶ Press [Mode] to access the main menu
> The display shows [R0]
- ▶ Press ▼ until [90] is displayed.
- ▶ Press [Mode]
> The display shows [9E P S]
- ▶ Press ▼ until [99t d] is displayed.
- ▶ Press [Mode]
> The display shows [t.d.E.L]
- ▶ Press ▼ until [t.R.C.t] is displayed.
- ▶ Press [Mode]
> The current sampling time or R0t0 is displayed.
- ▶ Press ▲ or ▼ for 2 seconds
> The display flashes three times.
- ▶ Press ▲ or ▼ to set the desired sampling time.
- ▶ Press [Mode] to confirm the parameter

Exit operation

- ▶ Wait 30 seconds

or

- ▶ Press ▲ or ▼ to change to the parameter [E r d]. Then press [Mode] to change to the functional menu.

- ▶ In the functional menu press ▲ or ▼ to change to the parameter [E n d], then press [Mode].

If the time delay t.d.E.L must also be adjusted, proceed as described above. In this case the parameter t.d.E.L must be selected and changed accordingly.

9.2 Setting the sampling time at the PX 80/81

The measuring time is set to 15 s in the delivery state. After the measuring time has expired, the measured temperature is shown on the display or the analogue output. Afterwards, the measuring time restarts automatically after the dead time has elapsed.

Two-colour channel [9 u] → ATD function [9 R t d]

Parameter	Function	Default
t.d.E.L	Time delay [s]	1 s
t.R.c.t	Sampling [s]	15 s

- ▶ Press [Mode] to access the main menu
> The display shows [R o]
- ▶ Press the ▼ until [9 u] is displayed.
- ▶ Press [Mode]
> The display shows [9 E P S]
- ▶ Press ▼ until [9 R t d] is displayed.
- ▶ Press [Mode]
> The display shows [t .d .E .L]
- ▶ Press ▼ until [t R c t] is displayed.
- ▶ Press [Mode]
> The current sampling time is displayed.
- ▶ Press ▲ or ▼ for 2 seconds
> The display flashes three times.
- ▶ Press ▲ or ▼ to set the desired sampling time.
- ▶ Press [Mode] to confirm the parameter

Exit operation

- ▶ Wait 30 seconds

or

- ▶ Press ▲ or ▼ to change to the parameter [E n d]. Then Press [Mode] to change to the functional menu.
- ▶ In the functional menu press ▲ or ▼ to change to the parameter [E n d], then press [Mode].



Alternatively, the parameters can be set via IO-Link.

EN

A detailed description of the parameters of the ATD function can be found in chapter "ATD Function".

10 Adaptation of temperature level

By changing the emissivity ratio, the difference between the measured temperature level and true temperature can be compensated.

For this purpose, a comparison measurement with an immersion lance is required.

Adjust emissivity ratio in such a way that the measured values coincide. An increase in the emissivity ratio results in a low temperature value.

The graph shows an approximation of the influence of the emissivity ratio setting on the change in temperature value.

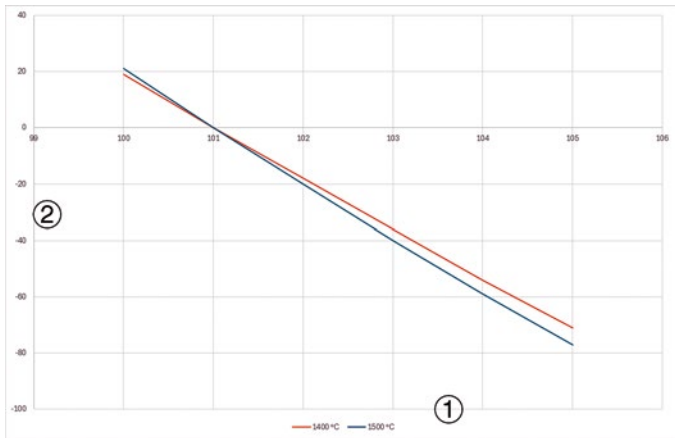

1	Ratio correction
2	Temperature difference [°C]

Experience has shown that the following settings apply as a first approximation

- grey pig iron 101
- spheroidal graphite iron 104

However, these values may differ in practice. After changing the emissivity ratio, carry out a new control measurement.

The emissivity ratio is set as follows:

- ▶ Press ▲ or ▼ for 2 seconds
- > The value of the selected emissivity ratio is displayed, for example [10 30]
- ▶ Press ▲ or ▼ until the desired emissivity ratio will show
- ▶ Release the ▲ or ▼ key
- > The current temperature values is displayed and the new emissivity ratio coefficient is stored

Alternatively, the emissivity ratio can be set via IO-Link.

EN

11 Shielding and Grounding

The pyrometer housing is connected to the shielding via the cable connector!

Differences in ground potentials might cause an equalising current to flow between devices through a cable shielded at both ends. In this case, be sure to install an additional equipotential bonding line.

To avoid an equalising current, the pyrometer can be mounted electrically insulated. The shielding must be connected to the plant's earthing system.

ATTENTION

If the pyrometer is installed without an insulator and without potential equalisation, the interference voltage may not exceed 32V.

12 Operating control and display

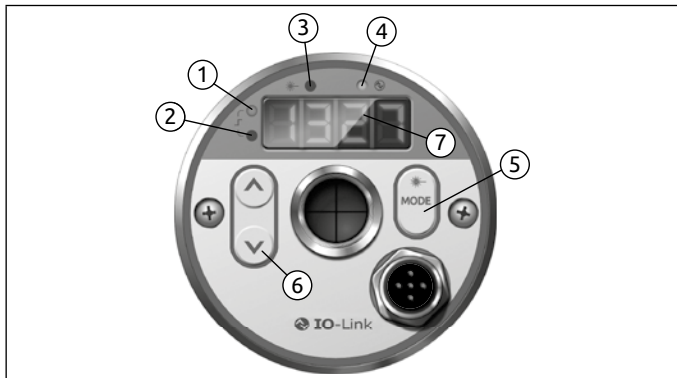

1 to 4: Indicator-LEDs

- LED 1 = Switching state of switching output OUT1
- LED 2 = Switching state of switching output OUT2
- LED 3 = Laser pilot light active
- LED 4 = IO-Link Communication

5: Control key [MODE]

- Selection of parameters
- Reading the set values
- Confirmation of parameter values

6: Control key [^] and [v]

- Selection of parameters
- Activation of emissivity quick adjustment
- Confirmation of parameter values

7: Alphanumeric display, 4-digit

- Indicates temperature value
- Indicates parameter and configuration
- Display of errors

12.1 Processing of measuring signals

The pyrometer disposes of an IO-Link interface.

The generated three output signals correspond to the parameterization:

- Out 1: Switching output/ IO-Link
 - Switch signal: threshold value temperature / status signal
- Out 2: Switching output
 - Switch signal: threshold for temperature / status signal
- Analogue output: 0/4 -20 mA
 - Analogue output for temperature

EN

12.2 Analogue output

The pyrometer converts the measuring signal into a temperature proportional analogue signal of 0/4 – 20 mA. The maximum load is 500 Ohm.

[R_{0F}] Changeover 0 -20 mA or 4 -20 mA

[R_{0SP}] defines at which measured value the output signal is 0/4 mA.

[R_{0EP}] defines at which measured value the output signal is 20 mA.

Maximum measuring range		Measuring range scaled	
1	initial value of the measuring range	3	Analogue start point
2	final value of the measuring range	4	Analogue end point

12.3 Switching threshold OUT 1

OUT1 changes its switching status when the configured upper or lower thresholds $[d\ I.S.P.]$ and $[d\ I.r.P.]$ are exceeded. Source $d\ I.S$ specifies the signal that is output at OUT1.

- Two-colour mode $[d\ I.] \rightarrow [d\ I.S] = 9$

First, the switching point $[d\ I.S.P.]$ is set in °C and °F and then the reset point $[d\ I.r.P.]$. When changing $[d\ I.S.P.]$, the $[d\ I.r.P.]$ also changes so that the difference remains the same. If the $[d\ I.S.P.]$ is reduced to such an extent that the distance can no longer be maintained (as the $[d\ I.r.P.]$ would otherwise move below its minimum), the $[d\ I.r.P.]$ is increased to its minimum. If $[d\ I.S.P.]$ is subsequently increased again, $[d\ I.r.P.]$ is also increased again immediately. The minimum distance between $[d\ I.S.P.]$ and $[d\ I.r.P.]$ is 1 K.

12.4 Output signal

The following output functions can be selected:

- Normally open contact $[d\ I.] \rightarrow [d\ I.F.n] = h.n.o$ hysteresis function, normally open or rather $F.n.o$ window function, normally open
- Normally closed contact $[d\ I.] \rightarrow [d\ I.F.n] = h.n.c$ hysteresis function, normally closed or rather $F.n.c$ windows function, normally closed

12.5 Switch on delay

Once the sensor has detected a temperature which exceeds the switching threshold $[d\ I.S.P.]$ the time delay $[d\ I.d.S]$ starts running. When this delay period has elapsed, the output OUT 1 activates switching. This status is sustained until the lower threshold $[d\ I.r.P.]$ is violated. If this occurs before the time delay has elapsed, the delay will reset. This function can be used, for example, to suppress spurious impulse signals at the output.

- Switching on delay: $[d\ I.] \rightarrow [d\ I.d.S] = 0...10$ sec.

12.6 Switch off delay

To make sure the output is correctly identified, e.g. by downstream control system, the output can be lengthened.

- Switch off delay: $[d\ I.] \rightarrow [d\ I.d.r] = 0...10$ sec.

12.7 Hysteresis function

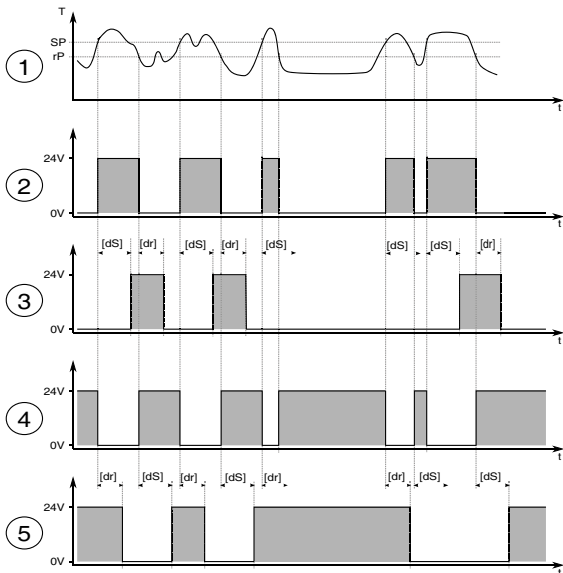

EN

T = temperature rP = reset point
 t = time dS = switch on delay
 SP = set point dR = switch off delay

1	Temperature
2	Switch signal h_{00}
3	Switch signal h_{00} with switch on delay and switch off delay
4	Switch signal h_{0c}
5	Switch signal h_{0c} with switch on delay and switch off delay

12.8 Window function

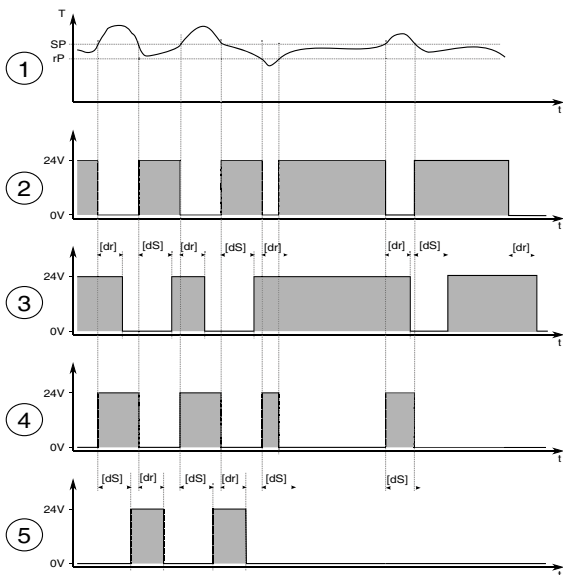

T = temperature rP = lower limit value
 t = time dS = switch on delay
 SP = upper limit value dr = switch off delay

1	Temperature
2	Switch signal F_{no}
3	Switch signal F_{no} with switch on delay and switch off delay
4	Switch signal F_{nc}
5	Switch signal F_{nc} with switch on delay and switch off delay



The switching thresholds of the window function have a hysteresis of 0.25% of the measuring range.

12.9 Switching output OUT 2

OUT2 changes its switching state according to the adjusted function. The functions and parameters are the same as OUT 1.

12.10 Dirt alert

A dirt alert function is available to ensure a safe measurement for the PX pyrometer. The dirt alert function warns the user if, for example, the lens, an attached protective glass or the sighting cone of the pyrometer gets dirty during a measurement.

EN

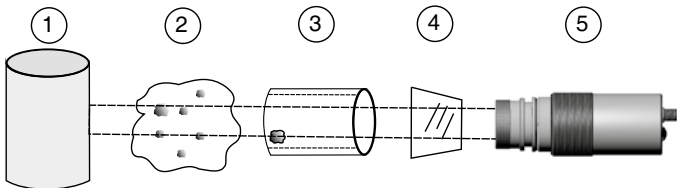

1	Target object
2	Visibility obstructed by vapour and dust
3	Deposits in the sight tube or kiln wall
4	Contaminated viewing window and/or contaminated lens
5	Pyrometer

The parameter dirt alert is activated with the parameter $[d 1] \rightarrow [d 1.5] = d, r$ or $[d 2] \rightarrow [d 2.5] = d, r$. The dirt alert is a warning function. The warning will become when the set threshold $[9] \rightarrow [9.d r t]$. During measurements of discontinuous processes, this warning is only active when the target object is detected by the pyrometer and the threshold is violated.

12.11 Damping function

When the target object's temperature is erratic, the damping function smoothens these temperature fluctuations in order to stabilize the measuring signal. The greater the time constant, the lower the effect of fluctuations on the yielded temperature reading.

Two-colour mode [9 0] → [9 F, L]

One-colour mode [L 1] → [F, L] or [L 2] → [F, L]

Ao

[mA]

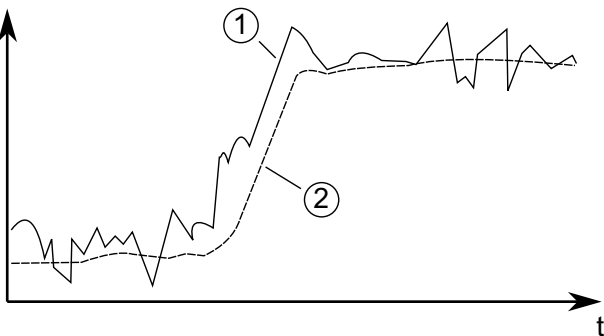

1	Output signal without smoothing function
2	Output signal with smoothing function

12.12 Peak hold function

It might often be desirable to determine the peak temperature during a defined time period, for example when the objects to be measured move past the pyrometer, resulting in temperature readings which would appear to be cyclical. In this mode, the displayed temperature reading will not drop between targeted objects. The peak temperature reading will be held for a preset time period.

The hold time [E , nE] can be set from 0.1 to 999.9 sec. The maximum temperatures sampled during the defined hold time will be saved. It make sense to

choose a hold time which is approximate 1.5 time as long as cycle of the moving targets. This avoids temperature drops. Any changes are recognised at once.

Two-colour mode [9] → [9Phd] → [t , nE]

One-colour mode [L 1] → ['Phd] → [t , nE] or
[L 2] → ['Phd] → [t , nE]

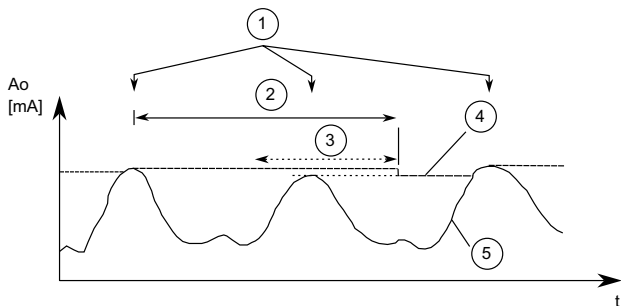

EN

1	Measuring object in front of the pyrometer
2	Hold time
3	Second internal hold time
4	Measuring reading with peak hold function
5	Measuring reading without peak hold function

12.13 ATD function

This function is used to automatically measure the temperature of a discontinuously running process. For example, it can be used to determine the temperature of objects passing the pyrometer acyclically and have a variable size or speed.

The start of a measuring cycle is determined automatically and is dependent on the following variables:

Limit 1 (L1.1)	Before beginning the measurement, the temperature reading must have been lower than Limit 1 at least once. If Autoreset [E R U E = 0 0] the limit 1 will be ignored
Limit 2 (L1.2)	Limit 2 must be exceeded at least for the duration of time delay [E d E L].
Time delay (E d E L):	See above

When the conditions are fulfilled, the sampling time can begin. [E R c E].

Sampling time (E R c E)	During the sampling time the temperature is detected and stored as a temperature value.
--------------------------------	---



If the parameter E R c E = 0, the end of the discontinuous process is also detected automatically (measured temperature < L2). The device then displays 'R U E 0' instead of the time for the parameter E R c E.

The parameter E R 0 0 defines the temperature emitted during the measuring time.

Display mode (E R 0 0)	„OFF“ displays the lower temperature range limit during the measurement. „hold“ indicates the previous temperature reading during the current measurement.
-------------------------------	---

The duration of the measurement time can optionally be signaled at switching output 1 or switching output 2.

When the sampling time has ended, an average value is calculated for recorded measuring cycles. The temperature reading is weighted with the previously saved average value and added.

Weighted average (E F P r)	Factor for average weighting. If you choose 100%, averaging will be off.
-----------------------------------	--

The smaller you set the E F P r factor, the stronger the weighting will be.

When the averaging function is activated (E F P r < 100%) a plausibility check will be performed. The difference in temperature between the current reading and the previously stored average is established. If the difference is higher than the

plausibility threshold TSP, the transmitted data will be „0“ and the average value will remain unchanged.

Plausibility (TSP)	Threshold for plausibility check: lower limit which is acceptable for a valid measurement.
Plausibility (TSP)	Threshold for plausibility check: upper limit which is acceptable for a valid measurement.

When sampling is completed, the average temperature value or „0“ will be output. At the same time, the switching outputs can be parameterized so that a status pulse is generated at the end of the measuring time. Enter **RRt** as source and set the hold time to 0.5 sec.

A cut-off interval (time lag) begins after the sampling time has ended. This cut-off interval must expire before the next measurement can start with the cycle starting conditions described above.

Cut-off interval (t_{off})	The interval between one completed sampling and the start of a new sampling.
---	--

If a measuring cycle does not start during the period **t_{off}**, the saved average will be deleted and reinitialized when the next cycle begins.

Timeout (t_{off})	Timeout für Mittelfunktion (in Minuten)
----------------------------------	---

Activate auto reset for the ATD function to run cyclically. Limit 1 will then be ignored. Measurement continues when the Limit 2 is exceeded for the period configured with **t_{del}**.

Auto reset (t_{del})	Auto reset on/off
-------------------------------------	-------------------

12.14 The parameter Set Li2 checks on **tAct** checks, whether the value falls below threshold 2 during the measuring time. If the value falls below the threshold, the measurement is rejected. The display shows „----“.

Set Li2 check on tAct (t_{Li2})	on/off
--	--------

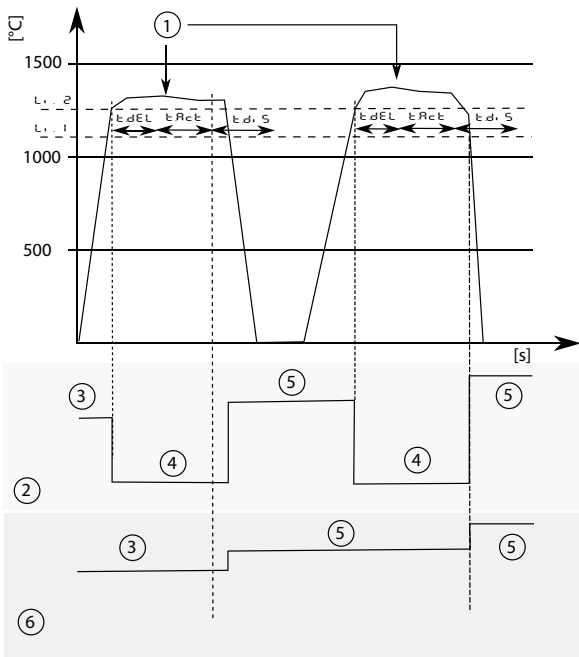

$L. 2$ = limit 2

$L. 1$ = limit 1

t_{dEL} = time delay

t_{Rct} = sampling time

$t_{d,S}$ = cut-off interval

1	Measuring object in front of the pyrometer
2	Temperature output $t_{Rno} = OFF$
3	Previous reading
4	Lower limit of temperature range
5	New reading
6	Temperature output $t_{Rno} = hold$

12.15 IO-Link

This device has an IO-Link communication interface, which requires an IO-Link-capable module (IO-Link master) for operation. The IO-Link interface allows direct access to process and diagnostic data and offers the possibility to parameterize the device during operation. The IO-DDs required for configuring the IO-Link device as well as detailed information on process data set-up, diagnostic functions and parameter addresses are available in the download area at www.keller.de/its.

For IO-Link operation a 3-wire cable port Class A (Type A) must be used.

EN

13 Menu

13.1 Analogue output Ao

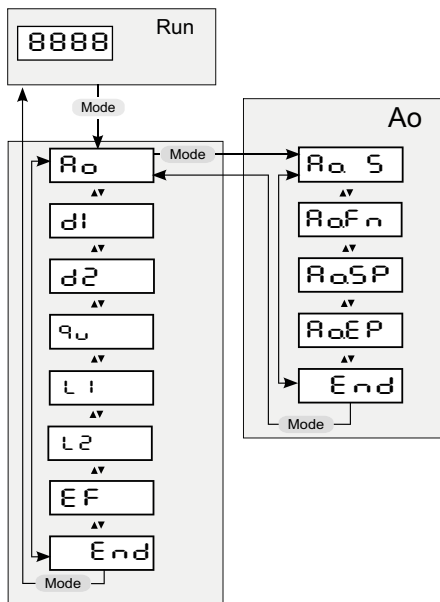

13.2 Switching output OUT 1

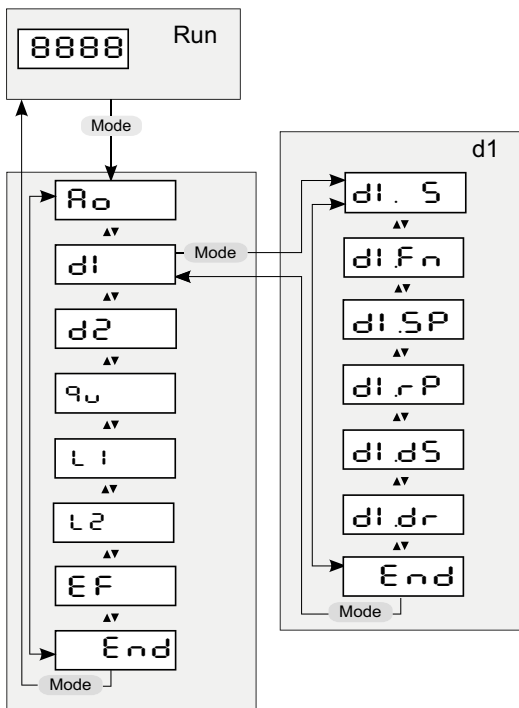

13.3 Switching output OUT 2

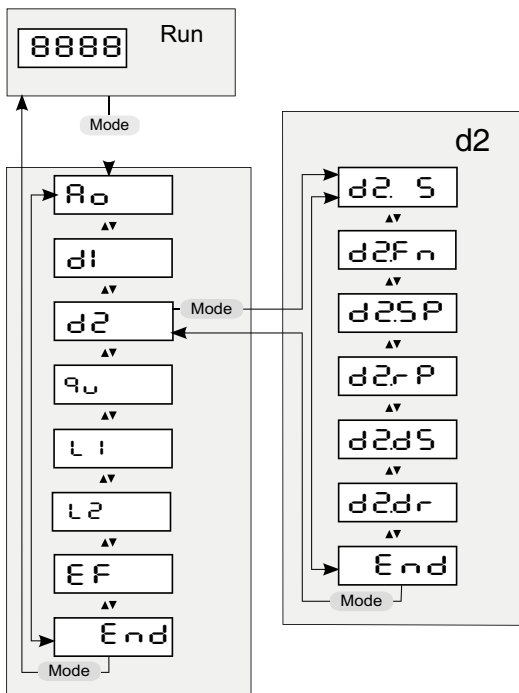

EN

13.4 Two-colour channel

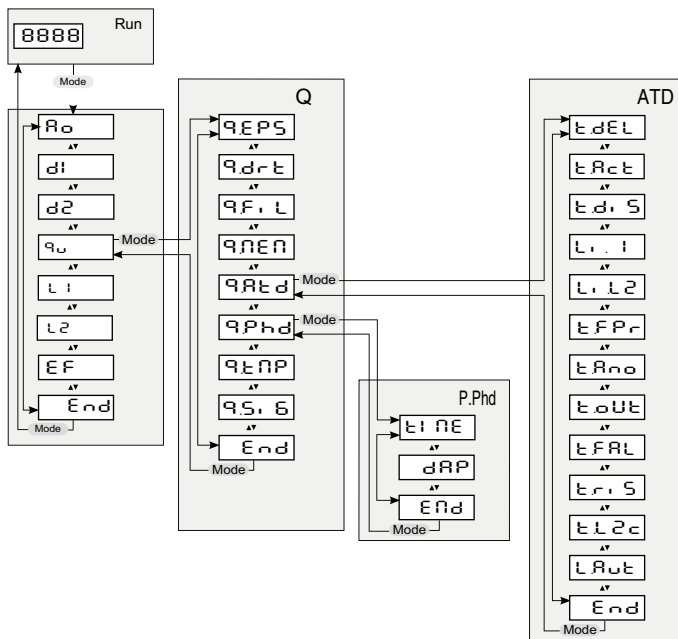

P.Ph.d	Peak Hold Function Submenu only available when Peak hold function is active
ATD	ADT Function Submenu only available when ATD function is active

13.5 Spectral channel Lambda 1

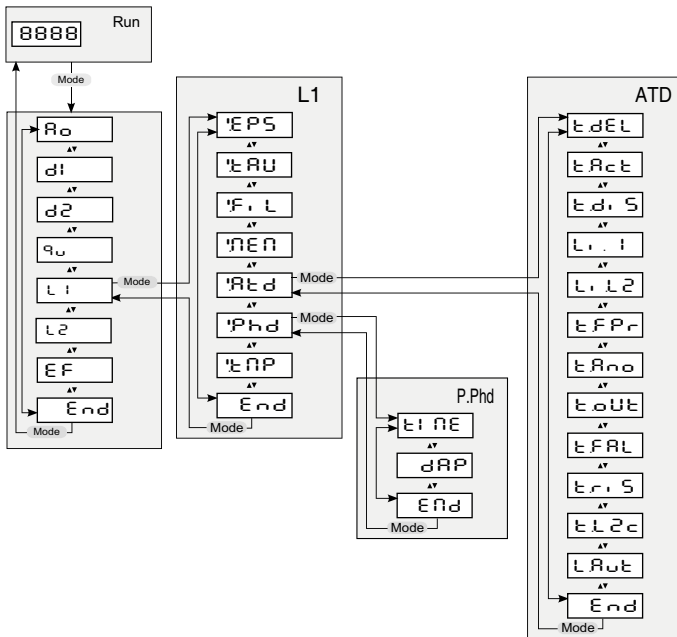

P.Ph.d	Peak Hold Function Submenu only available when Peak hold function is active
ATD	ADT Function Submenu only available when ATD function is active

13.6 Spectral channel Lambda 2

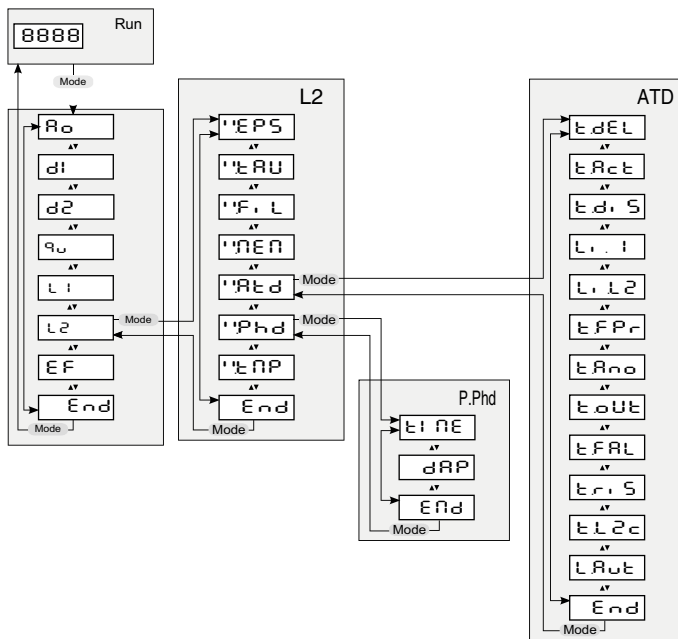

P.Ph.d	Peak Hold Function Submenu only available when Peak hold function is active
ATD	ADT Function Submenu only available when ATD function is active

13.7 Advanced Features

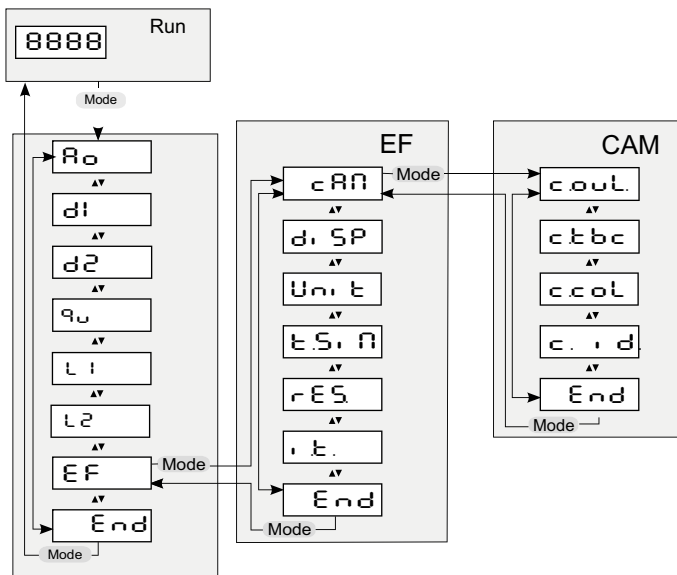

EN

CAM	Parameter and submenu only available at pyrometer with camera.
-----	--

14 Menu explanation

14.1 Analogue output

Parameter	Function	Comments
R _o S	Select source	L 1 Lambda 1 one-colour mode L 2 Lambda 1 one-colour mode 9 two-colour mode
R _o F _n	0/4 – 20 mA	0 – 20 mA 4 – 20 mA
R _o S _P	Define lower limit of temp. span	
R _o E _P	Define upper limit of temp. span	
E _n d	End	Exit menu

14.2 OUT 1 (d_i)

Parameter	Function	Comments
d _i . S	Select source	L 1 Lambda 1 L 2 Lambda 1 9 two-colour mode R _L 1 A ₁ ATD tAct (λ1) R _L 1 t ₁ ATD Trig (λ1) R _L 2 A ₂ ATD tAct (λ2) R _L 2 t ₂ ATD Trig (λ2) R ₉ A _c ATD tAct (two-colour mode) R ₉ t _r ATD Trig (two-colour mode) d _i r dirt alert t _U internal device temperature
d _i F _n	Output function	h _{no} hysteresis function normally open h _{nc} hysteresis function normally closed F _{no} window function normally open F _{nc} window function normally closed

d1 SP	Lower threshold	
d1 rP	Upper threshold	
d1 dS	Switch-on delay	0 – 10 s, 0.1 steps
d1 dr	Switch-off delay	0 – 10 s, 0.1 steps
End	End	Exit menu

14.3 OUT 2 (d2)

Parameter	Function	Comments
d2 S	Select source	L 1 Lambda 1 L 2 Lambda 1 9 two-colour mode AL 1: ATD tAct (λ1) AL 1t: ATD Trig (λ1) AL 2: ATD tAct (λ2) AL 2t: ATD Trig (λ2) AA Ac ATD tAct (two-colour mode) AA tr ATD Trig (two-colour mode) d r dirt alert t U internal device temperature
d2Fn	Output function	hno hysteresis function normally open hnc hysteresis function normally closed Fno window function normally open Fnc window function normally closed
d2SP	Lower threshold	
d2rP	Upper threshold	
d2dS	Switch-on delay	0 – 10 s, 0.1 steps
d2dr	Switch-off delay	0 – 10 s, 0.1 steps
End	End	Exit menu

14.4 Two-colour channel (᠑᠘)

Parameter	Function	Comments	
᠑᠘᠑᠑᠑	Ratio correction	80... 120 %	
᠑᠘᠑᠑᠑	Pollution warning level	0.1 - 100	
᠑᠘᠑᠑᠑	Relative lower limit, two-colour temperature reading invalid (signal intensity)	0.1 – 100 signal intensity	
᠑᠘᠑᠑᠑	Smoothing time	0 - 999,9	
᠑᠘᠑᠑᠑	Memory function	᠐᠒᠒ off ᠑᠑᠑ ATD function ᠑᠑᠑ Peak-Hold function	
᠑᠘᠑᠑᠑**	Opening of the lower menu level ATD function**		
᠑᠘᠑᠑᠑	᠑᠘᠑᠑᠑	Time delay	See chapter ATD function
	᠑᠘᠑᠑᠑	Sampling time	
	᠑᠘᠑᠑᠑	Cut-off intervall	
	᠑᠘᠑᠑᠑	Limit 1	
	᠑᠘᠑᠑᠑	Limit 2	
	᠑᠘᠑᠑᠑	Weighted average	
	᠑᠘᠑᠑᠑	Display mode	
	᠑᠘᠑᠑᠑	Timeout	
	᠑᠘᠑᠑᠑	Threshold for plausibility check: lower limit	
	᠑᠘᠑᠑᠑	Threshold for plausibility check: upper limit	

Parameter	Function	Comments
ε L 2 c	Check, whether threshold 2 is fallen below during the measuring time	See chapter ATD function
ε R U ε	Autoreset	
ε n d	Closing of the lower menu level ATD function	
9 P h d *	Opening of the lower menu level Peak-Hold function*	
ε . n ε	Hold time Peak-Hold function	Time in second
d R P	Damping	Damping
ε n d	Closing of the lower menu level Peak-Hold function	
9 ε n P	Actual temperature reading	The display shows the actual temperature reading.
9 S . 6	Signal-intensity	The display shows the actual calculated signal-intensity.
ε n d	End	Exit menu

EN

* Parameter and lower menu level can only selected with active Peak-Hold function

** Parameter and lower menu level can only selected with active ATD function

14.5 Spectral channel (L 1) (L 2)

Parameter	Function	Comments
EPS	Emissivity	Correction of the radiation properties of the measured object (10...110%)
TRU	Transmission factor	When using protection shields, the value of the transmission of the used disk can be entered here.
FIL	Smoothing time	
MEM	Memory function	OFF Off PHLD Peak-Hold function ATD ATD function
ATD**	Opening of the lower menu level ATD Function**	
	TDL	Time delay
	TRC	Sampling time
	TDI	Cut-off interval
	L1	Limit 1
	L2	Limit 2
	WAV	Weighted average
	DMO	Display mode
	TOU	Timeout
	FLR	Threshold for plausibility check: lower limit
	URS	Threshold for plausibility check: upper limit
		See chapter ATD function

Parameter	Function	Comments
$\epsilon L 2 c$	Check, whether threshold 2 is fallen below during the measuring time	See chapter ATD function
$\epsilon n d$	Closing of the lower menu level ATD Function	
Phd^*	Opening of the lower menu level Peak-Hold Function*	
$\epsilon, n \epsilon$	Hold time Peak-Hold function	Time in sec.
dRP	Damping	Damping
$\epsilon n d$	Closing of lower menu level Peak-Hold Function	
$\epsilon n P$	Actual temperature reading	The display shows the actual temperatur reading
$\epsilon n d$	End	Exit menu

* Parameter and lower menu level can only be selected with active Peak-Hold Function

** Parameter and lower menu level can only be selected with active ATD function

14.6 Advanced Features (EF)



Parameter	Function	Comments	
cAN*	Opening of the lower menu level of the camera		
c	ccoul.	Screen insert temperature reading	on off
	ctbc.	TBC exposure metering	on spot weighted off average
	ccol	White balance	AUTO. automatic DAYL daylight.
	c.i.d.	Measuring point number	OFF 1 -99 display of the measuring point number in the camera display
	End	Closing of the lower menu level of the camera	
di.SP	Process value display	on current temperature value OFF run is shown on the display	
Unit	Temperature unit	Temperature displayed in °C or °F	
tsi	Temperature Simulation	A temperature can be simulated	
res	Factory settings	Reset to factory settings	
it	Internal device temperature	The display shows the actual internal device temperature reading	
End	End	Exit menu	

* Parameter only available for models with camera

15 Parameterizing

When you reset/adjust the operating parameters, the instrument remains in run mode. It continues to operate, using the current parameter settings, until you have finished configuring by pressing [MODE].

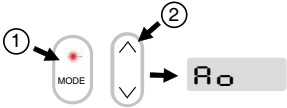
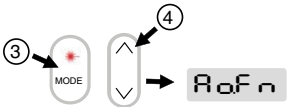
15.1 Setting parameters – general information

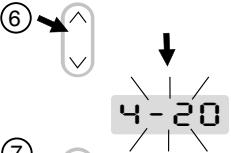
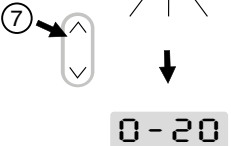
<p>1 Select main menu</p> <ul style="list-style-type: none"> ▶ Press [MODE] to access the main menu. 		EN
<p>2 ▶ Press [∧ oder ∨] until the required output function or advanced features is displayed.</p>		
<p>3 Select parameter</p> <ul style="list-style-type: none"> ▶ Press [MODE]. 		
<p>4 ▶ Press [∧ or ∨] until the required parameter is displayed</p>		
<p>5 Change parameter value</p> <ul style="list-style-type: none"> ▶ Press [MODE]. > Current parameter value is displayed. 		
<p>6 ▶ Press [∧ or ∨] for 2 second.</p> <ul style="list-style-type: none"> > >Display flashes three times. 		
<p>7 ▶ Press [∧ or ∨] to change the parameter.</p> <ul style="list-style-type: none"> ▶ Hold key [∧ or ∨]. > Numerical values scroll through rapidly. 		

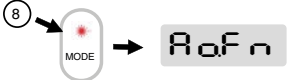
8	<p>Confirm parameter value</p> <ul style="list-style-type: none"> ▶ Press [MODE]. > The display indicates the parameter. The new value has been saved and will take effect. 	
<p>Exit operating parameter layer</p> <ul style="list-style-type: none"> ▶ Wait 30 seconds <p>or</p> <ul style="list-style-type: none"> ▶ Press [^ or v] to change to the parameter $E n d$. Then press [MODE] to change to the functional menu. ▶ In the functional menu press [^ or v] to change to the parameter $E n d$, then press [MODE]. 		



If you press both keys [^ v] only briefly, you will exit the layer (ESC) function.

16 Error indications

Overload switching output	$S c$ and flashing of the LED Out 1/2
Overtemperature	Display off and the process value change with 0.5 Hz
Incorrect connection of supply voltage	The display is turned off
Supply voltage ≤ 16 V	The display is turned off
Temperature below measuring range	The display shows UL
Temperature above measuring range	The display shows OL

17 Service functions

17.1 Reset all parameters to factory settings

▶	[r E S] Select extended functions [E F] in the menu
▶	Press [MODE]
>	RES is shown in the display
▶	Press the v key for 2 s
>	RES flashed for 2 s
▶	Release the key v key and press it again
>	---- is shown in the display
▶	Press [MODE] button
>	The current temperature is shown in the display

EN

17.2 Simulate a desired temperature

▶	[t S, n] Select extended functions [E F]
▶	Press [MODE]
>	The display shows the previously set temperature
▶	Press the ^ key for 2 s
>	Temperature flashes 3 times
▶	Use the keys ^ v to set the desired temperature, release the key
>	The display alternately shows t S, n and the temperature value
▶	Press [MODE] button
>	The display shows t S, n and the simulation is completed

Exit operating parameter layer

- ▶ Wait 30 seconds

or

- ▶ Press [^ or v] to change to the parameter End. Then press [MODE] to change to the functional menu.
- ▶ In the functional menu press [^ or v] to change to the parameter End, then press [MODE].

18 Maintenance

18.1 Cleaning the pyrometer lens

A soiled lens leads to wrong display of the measured value.

- ▶ Check the lens regularly and clean it, if required.
 - Remove dust by blowing or with a soft brush.
 - Use clean, soft and lint-free cloths or those offered on the market for lens cleaning.
 - For heavier contamination, use washing-up liquid or liquid soap. Then carefully rinse with clear water. Hold the lens downwards.
 - Exert only little pressure on the lens during cleaning to avoid scratches.

18.2 Replacing the protective screen

To protect the pyrometer optics against contamination in harsh industrial environments, an additional protective screen is often used. A contamination of the protective screen also leads to a reduced indication of the measuring value.

- ▶ Check the protective screen regularly and clean it if necessary or replace it in case of damage.
 - Remove dust by blowing or with a soft brush.
 - Use clean, soft and lint-free cloths or those offered on the market for lens cleaning.
 - For heavier contamination, use washing-up liquid or liquid soap. Then carefully rinse with clear water. Hold the lens downwards.
 - Exert only little pressure on the protective glass during cleaning to avoid scratches.

ATTENTION

Replacement of the protection glass only by authorized person. When removing the protective screen, always wear **protective glasses and -gloves**.

19 Trouble shooting

19.1 No measured values are determined

The CellaCast measuring system checks the validity of the measured values for each measurement and calculates the signal strength. The value for the signal strength must be > 5%. The signal strength is only displayed during casting.

Parameter	Calculated signal strength
RS, 6	In [%]

EN

Checking the signal strength

- ▶ Press [Mode]
 - > The display shows [Ao]
- ▶ Press ▼ until [RS] is displayed.
- ▶ Press [Mode]
 - > Im Display wird [REPS] angezeigt
- ▶ Press ▼ until [RS, 6] is displayed.
- ▶ Press [Mode]
 - > The display shows the currently calculated signal strength.

If the displayed signal strength is < 5 %, the following checks must be carried out:

Check lens or protective glass for dirt.

Check the alignment and focusing.

- The pyrometer must be focused to the measuring distance.
- The measuring field must be filled to 30 %.
- The pyrometer must have a clear view of the pouring stream.

20 Models

Pyrometer		
Type	Temp. range	Application
PX 83	650 - 1700 °C 750 - 2400 °C	For measurement of liquid metals (discontinuous casts)
PX 80	750 - 2400 °C	For measurement of liquid metals (continuous casting)
PX 81	800 - 2400 °C	For measurement of liquid metals (continuous casting)

21 Field of view

With a pyrometer with focusable optics, the size of the measurement field is determined by the distance ratio D . The measurement field diameter d at the focal distance is defined by the formula:

$$d = \frac{a}{D}$$

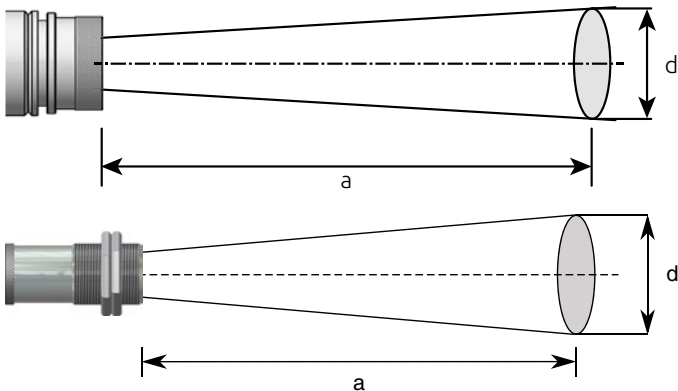

In case of rectangular measurement fields, the horizontal D_H and the vertical D_V distance ratio is indicated.

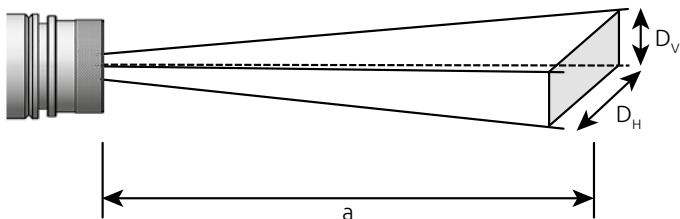

On our website you will find a measurement field calculator. Select the suitable pyrometer, enter the measuring distance and the length of the measurement field and you will get the suitable measurement field course and you can see the size of the measuring spot at the relevant distance.

<https://www.keller.de/en/its/tools/field-of-view-calculator.htm>

22 General technical data

Pyrometer	
Analogue output	0(4) -20 mA linear according NAMUR 43, switchable. scalable load 500 Ω
Switching output OUT1	PNP Open Collector outputs 24 V, \leq 150 mA Switch point [$^{\circ}$ C]/ return switch [$^{\circ}$ C], hysteresis \geq 2 K, on/switch-off delay, NC/ NO or IO-Link
Switching output OUT2	PNP Open Collector outputs 24 V, \leq 150 mA Switch point [$^{\circ}$ C]/ return switch [$^{\circ}$ C], hysteresis \geq 2 K, on/switch-off delay, NC/ NO
Ambient temperature	0- 65 $^{\circ}$ C (without cooling)
Zul. Umgebungstemperatur (Lichtleiterausföhrung)	Basic unit 0 – 65 $^{\circ}$ C (without cooling) Measuring head and fibre optic cable 0 – 250 $^{\circ}$ C
IO-Link revision	V1.1, download compatible to V1.01
SIO mode	yes, supported
Transmission rate	COM2 (38.400 Baud)
Storage temperature	-20 – 80 $^{\circ}$ C
Permissible humidity	95 % r.H. max. (non condensing)
Power supply	24 V DC +10 % / -20 % ripple \leq 200 mV
Current consumption (without switching output)	\leq 135 mA \leq 150 mA with laser pilot light \leq 175 mA with camera
Housing material	Stainless steel
Weight	Approx. 1 kg (according model)
Connectivity	5-pin connection M12 (A coded)
Protection	IP 65 according DIN 40050 with screwed plug

Configuration parameter	Ratio correction 80 – 120 % Emissivity $\lambda 1, \lambda 2 \varepsilon$ 10 - 110 % Transmission factor $\lambda 1, \lambda 2$ Smoothing time t_{98} 0.1 – 999.9 s Peakhold Function 0.1 – 999.9 s ATD function
Sighting device	Through-the-lens sighting with target marking, laser spot light or integrated camera
Dimensions	Ø 65 x 220 mm (without plug)
Abmessungen Lichtleiterausführung	Ø 65 x 187 mm (basic unit without plug) Ø 30 x 67...86 mm (LWL measuring head M30)
Camera	
Video system	Composite PAL, 1 Vpp, 75 Ohm
Resolution	722 x 576 pixel
Target brightness control (TBC)	Spot weighted or integrated about the camera image
Screen display	Target marker, measurement
Connection	Pyrometer: TNC plug Monitor: chinch or BNC

23 Device-specific technical data

PX 83	
Temperature range	650 - 1700 °C 750 - 2400 °C
Sensor	Photodiode
Spectral sensitivity	0.95/1.05 µm
Focussing range	0.3 - ∞ optic PZ 20.08 0.4 m - ∞ optic PZ 20.01 1.2 m - ∞ optic PZ 20.06 0.2 m - ∞ optic PZ 20.05
Distance to target-size ratio	Temperature range 650 - 1700 °C Dv = 150:1, Dh = 30:1 (PZ 20.08) Dv = 230:1, Dh = 45:1 (PZ 20.01) Dv = 375:1, Dh = 75:1 (PZ 20.06) Dv = 55:1, Dh = 10:1 (PZ 20.05) Temperature range 750 - 2400 °C Dv = 350:1, Dh = 50:1 (PZ 20.01) Dv = 580:1, Dh = 85:1 (PZ 20.06) Dv = 85:1, Dh = 11:1 (PZ 20.05)
Resolution current output	0.2 K + 0.03 % of selected range
Resolution temperature reading	1 K
Reponse time t_{98}	Temperature range 650 - 1700 °C ≤ 10 ms (T > 750 °C) Temperature range 750 - 2400 °C ≤ 10 ms (T > 950 °C)
Measurement uncertainty	1.5 % of reading (at $\epsilon = 1.0$ and $T_u = 23$ °C)
Repeatability	3 K
Temperature coefficient	≤ 0.05 %/K of temp. reading / K with reference to 23°C

PX 80	
Temperature range	750 - 2400 °C
Sensor	Photodiode
Spectral sensitivity	0.95 / 1.05 μm
Focussing range	0.4 m - ∞ optic PZ 20.01 1.2 m - ∞ optic PZ 20.06
Distance to target-size ratio	150:1 (PZ 20.01) 240:1 (PZ 20.06)
Resolution current output	0.2 K + 0.03 % of selected range
Resolution temperature reading	1 K
Reponse time t_{98}	≤ 10 ms ($T > 950$ °C)
Measurement uncertainty	1 % of reading (at $\epsilon = 1.0$ and $T_u = 23$ °C)
Repeatability	2 K
Temperature coefficient	≤ 0.05 %/K of temp. reading / K with reference to 23°C

EN

PX 81	
Temperature range	800 - 2400 °C
Sensor	Photodiode
Spectral sensitivity	0.95/ 1.05 µm
Focussing range	0.2 m - ∞ optic (PA 41.01) M30
Distance to target-size ratio	190:1 (PZ 41.01)
Resolution current output	0.2 K + 0,03 % of selected range
Resolution temperature reading	1 K
Reponse time t_{98}	≤ 20 ms (T > 850 °C)
Measurement uncertain	1.5 % of reading (at $\epsilon = 1.0$ and $T_u = 23$ °C)
Repeatability	3 K
Temperature coefficient	≤ 0.05 %/K of temp. reading / K with reference to 23°C

24 Field of view camera

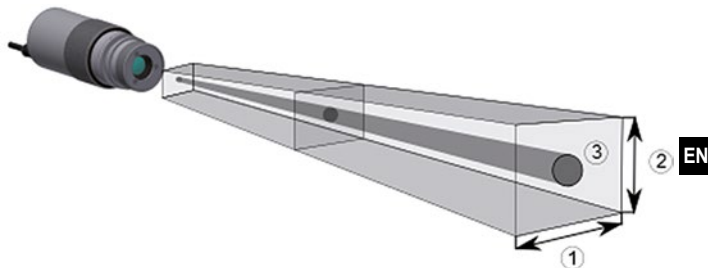

EN

1	Horizontal extent of the visual filed HFOV
2	Vertical extent of the visual filed VFOV
3	Field of view pyrometer

Optics	PZ 20.01		PZ 20.03		PZ 20.06	
Measuring distance [m]	HFOV [mm]	VFOV [mm]	HFOV [mm]	VFOV [mm]	HFOV [mm]	VFOV [mm]
0.2			8.5	6.4		
0.3			14	11		
0.4	16	12	20	15		
1	45	34				
1.2	54	41			33	24
2	92.7	70			56	42
3	140	105			86	65
4	188	141			116	87
5	236	177			146	110
6	284	213			176	132
7	332	249			206	154
8	379	285			236	177
9	427	320			266	199
10	475	356			295	222

Optics	PZ 20.05		PZ 20.08	
	HFOV [mm]	VFOV [mm]	HFOV [mm]	VFOV [mm]
Measuring distance [m]				
0.2	41.7	31.3		
0.3			20	15
0.4	79.4	59.6	27	20
1	193	144	70	52
1.2	230	173	84	63
2	381	286	142	106
3	570	427	213	160
4	759	569	285	214
5	947	710	357	267
6	1136	852	428	321
7	1324	993	500	375
8	1513	1135	572	429
9	1702	1276	643	482
10	1890	1418	715	536

25 Accessories

A range of mechanical and electrical accessories are available for mounting the pyrometers in industrial environments.

For the selection of the components use the following link:

<https://www.keller.de/en/its/pyrometer/accessories>

26 Default settings

The default settings can be found in the descriptions of the IODD. You can find them on the respective device pages on our homepage www.keller.de/en/its/pyrometer

27 Copyright

The licence information of the Open Source libraries used can be found in the media center on our homepage www.keller.de/en/its

Copyright prohibits the reproduction or distribution of this instruction manual, including text, photographs or images contained herein, in whole or in part, for any purpose whatsoever, without prior consent of the author. This applies to any form of mechanical or electronic reproduction as well as to electronic transmission in any form through any medium.

Please note:

Unless otherwise stated in this instruction manual, the instruments described herein are subject to change without prior notice, particularly modifications for the sake of technological advancement.

© 2019 KELLER HCW GmbH
Carl-Keller-Straße 2-10
D-49479 Ibbenbüren-Laggenbeck
Germany
www.keller.de/its

